

# **CECOR®**

## **OPERATION MANUAL & PARTS LIST**

### **MODELS:**

**SP50 HORIZONTAL TANK SERIES**

**200, 300, 400, 500, 600 GALLONS**



# TABLE OF CONTENTS

SECTION 1 – SAFETY INFORMATION .....	4
1.1 – CAUTION .....	4
1.2 – PRECAUTIONS .....	5
SECTION 2 – THE SUMP CLEANER .....	6
2.1 – UNIT IDENTIFICATION .....	6
2.2 – MODEL & SERIAL NUMBER .....	7
2.3 – SUMP CLEANER FEATURES.....	8
SECTION 3 – INSTALLATION .....	10
3.1 – ASSEMBLE DISCHARGE CONNECTION.....	10
3.2 – LOOSE ITEMS.....	10
3.3 – INITIAL STARTUP .....	12
3.3.1 – SELECTOR VALVE .....	12
3.3.2 – SECURE TANK PORTS.....	13
3.3.3 – STARTING ENGINE.....	13
3.3.4 – RUN UNIT IN “SUCTION” .....	15
3.3.5 – RUN UNIT IN DISCHARGE .....	16
3.3.6 – SHUTTING ENGINE OFF .....	16
SECTION 4 – OPERATION .....	17
4.1 – CLEANING A SUMP .....	17
4.2 – DISCHARGING FLUID FROM THE SUMP CLEANER.....	18
4.3 – FILTER .....	18
4.3.2 – F50 FILTER .....	19
4.4 – CLEANING THE SUMP CLEANER .....	23
SECTION 5 – MAINTENANCE .....	25
5.1 – DAILY MAINTENANCE.....	25
5.2 – WEEKLY MAINTENANCE .....	25
5.3 – MONTHLY MAINTENANCE .....	26
SECTION 6 – TROUBLESHOOTING .....	27
6.1 – SUCTION .....	27
6.2 – DISCHARGE.....	28
6.3 – MUFFLER LEAKING FLUID.....	28
SECTION 7 – REPAIR PARTS LIST .....	29

7.1 – WHEELS & CASTER .....	29
7.1.1 “PTL” PUSH TOW WHEEL TRANSPORT 90-175 GAL.....	29
7.1.3 “TW” TOW WHEEL TRANSPORT 300 & 400 GAL.....	30
7.1.4 “TW” TOW WHEEL TRANSPORT 500 GAL .....	31
7.2 – TANK.....	32
7.3 – SP50 PUMP.....	33
7.4 – F50 FILTER .....	35
7.5 – TANK CONNECTIONS & CONSUMABLES .....	36
7.6 – FILTER, TOOLS & HOSE .....	39
SECTION 8 – WARRANTY.....	41
SECTION 9 – RECORD MODEL & SERIAL NUMBER .....	42

## SECTION 1 – SAFETY INFORMATION

### 1.1 – CAUTION

 FLAMMABLE INFLAMMABLE	 <b>CAUTION</b>
	THIS EQUIPMENT IS INTENDED FOR USE WITH STANDARD METALWORKING FLUIDS (WATER-BASE & CUTTING OILS) ONLY. IT SHOULD NOT BE USED WITH FLAMMABLE FLUIDS, (FUELS, PAINT, SOLVENTS, ETC.) CORROSIVE, TOXIC OR REACTIVE MATERIALS. DO NOT USE IN EXTRA-HIGH TEMPERATURE OR SPARK-HAZARD ENVIRONMENTS (OVENS WELDING AREAS, ETC.). CLEAN TANK THOROUGHLY ON A FREQUENT BASIS, ESPECIALLY WHEN PUMPING DIFFERENT TYPES OF COOLANTS AND SOLIDS OF DIFFERENT MATERIAL. WE RECOMMEND SEPARATE TANK UNITS FOR DIFFERENT SERVICES AND SEGREGATED HANDLING OF DIFFERENT COOLANTS.
	 <b>CUIDADO</b>
	ESTE EQUIPO ES PARA USO CON FLUIDOS REGULARES DE CORTE (BASE AGUA Y ACEITES DE CORTS) EXCLUSIVAMENTE. NO SE DEBE USAR CON LÍQUIDOS INFLAMABLES, (COMBUSTIBLES, PINTURA, DISOLVENTES, ETC.), MATERIALES CORROSIVOS, TÓXICOS O REACTIVOS. NO UTILIZAR EN AMBIENTES DE TEMPERATURAS ALTAS O DONDE HAY RIESGO DE CHISPAS PELIGROSAS (HORNO, AREAS DE SOLDADURA, ECT.). LIMPIA A FONDO EL TANQUE DE MANERA FRECUENTE, ESPECIALMENTE CUANDO BOMBEE TIPOS DIFERENTES DE FLUIDO DE CORTE Y SÓLIDOS DE MATERIAL DISTINTO . RECOMENDAMOS UNIDADES SEPARADO DE DEPÓSITO DE LOS DIFERENTES SERVICIOS Y SEPARADO EL MANEJO DE DIFERENTES FLUIDO DE CORTE.
 TOXIC TÓXICO	
 CORROSIVE CORROSIVO	
 REACTIVE REACTIVIDAD	

THIS EQUIPMENT IS INTENDED FOR USE WITH STANDARD MACHINE-TOOL COOLANT (WATER-BASE AND CUTTING OILS) ONLY. IT SHOULD NOT BE USED WITH FLAMMABLE FLUIDS (I.E. FUELS, PAINT, SOLVENTS, ETC.), CORROSIVE, TOXIC OR REACTIVE MATERIALS. DO NOT USE IN EXTRA-HIGH TEMPERATURE OR SPARK-HAZARD ENVIRONMENTS (I.E. OVENS WELDING AREAS, ETC.). CLEAN TANK THOROUGHLY ON A FREQUENT BASIS, ESPECIALLY WHEN PUMPING DIFFERENT TYPES OF COOLANT AND SOLIDS OF DIFFERENT MATERIAL. WE RECOMMEND SEPARATE TANK UNITS FOR DIFFERENT SERVICES AND SEGREGATED HANDLING OF DIFFERENT COOLANTS.

- NO FLAMMABLE FLUIDS/MATERIALS WITH A FLASH POINT UNDER 200°F.
- NO TOXIC MATERIALS.
- NO CORROSIVE MATERIALS WITH PH LESS THAN 5 OR GREATER THAN 12.
- NO REACTIVE MATERIALS.

## 1.2 – PRECAUTIONS

- READ THROUGH THE "OPERATIONS MANUAL" COMPLETELY BEFORE ATTEMPTING TO OPERATE THE MACHINE.
  
- CLEANOUT, POT LID, INLET CAP AND HOSES MUST BE IN PLACE AND TIGHTLY SECURED BEFORE OPERATION IN THE DISCHARGE MODE.
  
- TANK DISCHARGE PRESSURE MUST NOT EXCEED 10 PSI. REGULATOR AND RELIEF VALVES ARE SET BEFORE SHIPMENT AND SHOULD NOT BE CHANGED AS THE USE OF EXCESSIVE PRESSURE COULD CAUSE SERIOUS INJURY OR DAMAGE. OPERATING DISCHARGE PRESSURE IS 6 PSI.
  
- DO NOT ATTEMPT TO OPEN POT LID, CLEANOUT OR BLEED-OFF CAP BEFORE RELIEVING PRESSURE IN THE TANK.
  
- BLOCK WHEELS OF THE MACHINE TO PREVENT UNINTENTIONAL MOVEMENT.
  
- WEAR SAFETY GOGGLES TO PROTECT EYES FROM SPLASHING LIQUIDS.
  
- KEEP HANDS AND FINGERS CLEAR OF POT OPENING WHEN REMOVING OR REPLACING FILTER BASKET OR FILTER ASSEMBLY.

## SECTION 2 – THE SUMP CLEANER

### 2.1 – UNIT IDENTIFICATION

WHEN ORDERING PARTS OR ASKING QUESTIONS REGARDING YOUR SUMP SHARK, IT IS IMPORTANT TO HAVE THE MODEL AND SERIAL NUMBER OF THE UNIT. THE MODEL AND SERIAL NUMBER CAN BE FOUND ON THE SHARK'S NAMEPLATE LOCATED ON THE SIDE PANEL OF THE PUMP BASE.

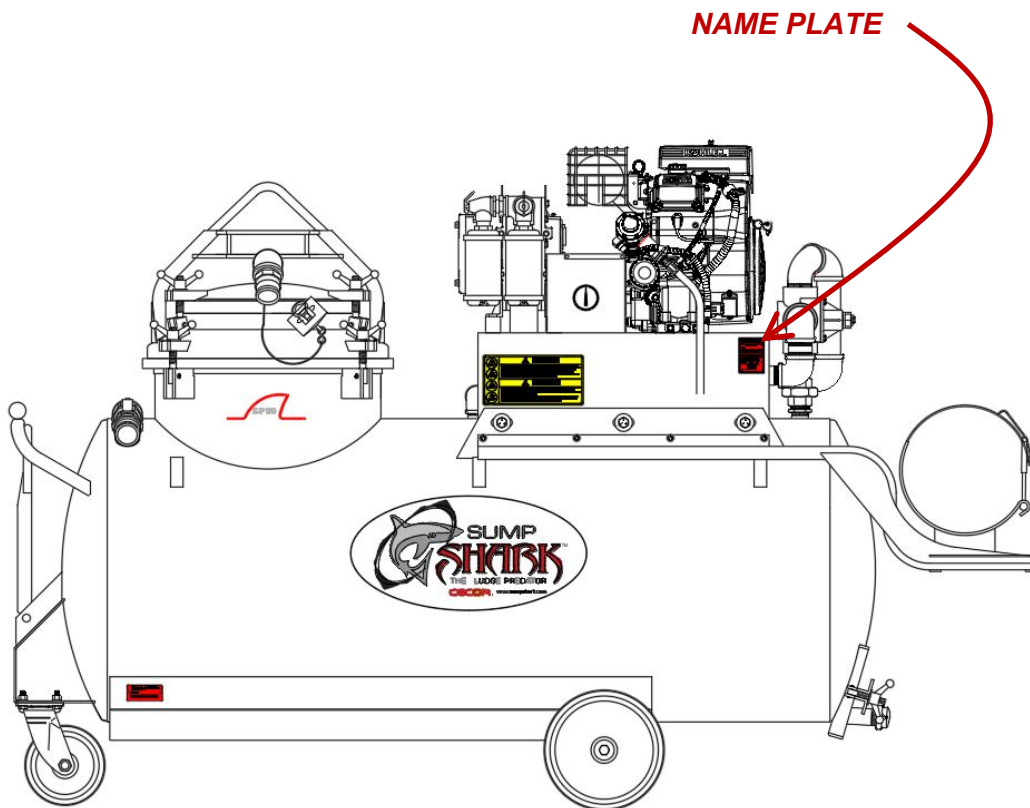

## 2.2 – MODEL & SERIAL NUMBER

THE MODEL NUMBER IDENTIFIES YOUR SHARK AND INDICATES STANDARD FEATURES ON YOUR MACHINE. THE SERIAL NUMBER IDENTIFIES YOUR SPECIFIC SHARK AND WILL HELP IDENTIFY ANY SPECIAL FEATURES THAT MAY BE UNIQUE TO YOUR SUMP SHARK. THE SERIAL NUMBER IS LOCATED ON THE NAMEPLATE.

**CECOR.**

CECOR filter cartridges bear  
US patent number 4,397,745

**MODEL**  
SP50-200PTL-HD

**SERIAL**  
SP50-###-##

PSI

VOLT  HZ  PH

1000 James Ave.  
Belleville, WI 53508

608-845-6771 [www.cecort.net](http://www.cecort.net)

## 2.3 – SUMP CLEANER FEATURES

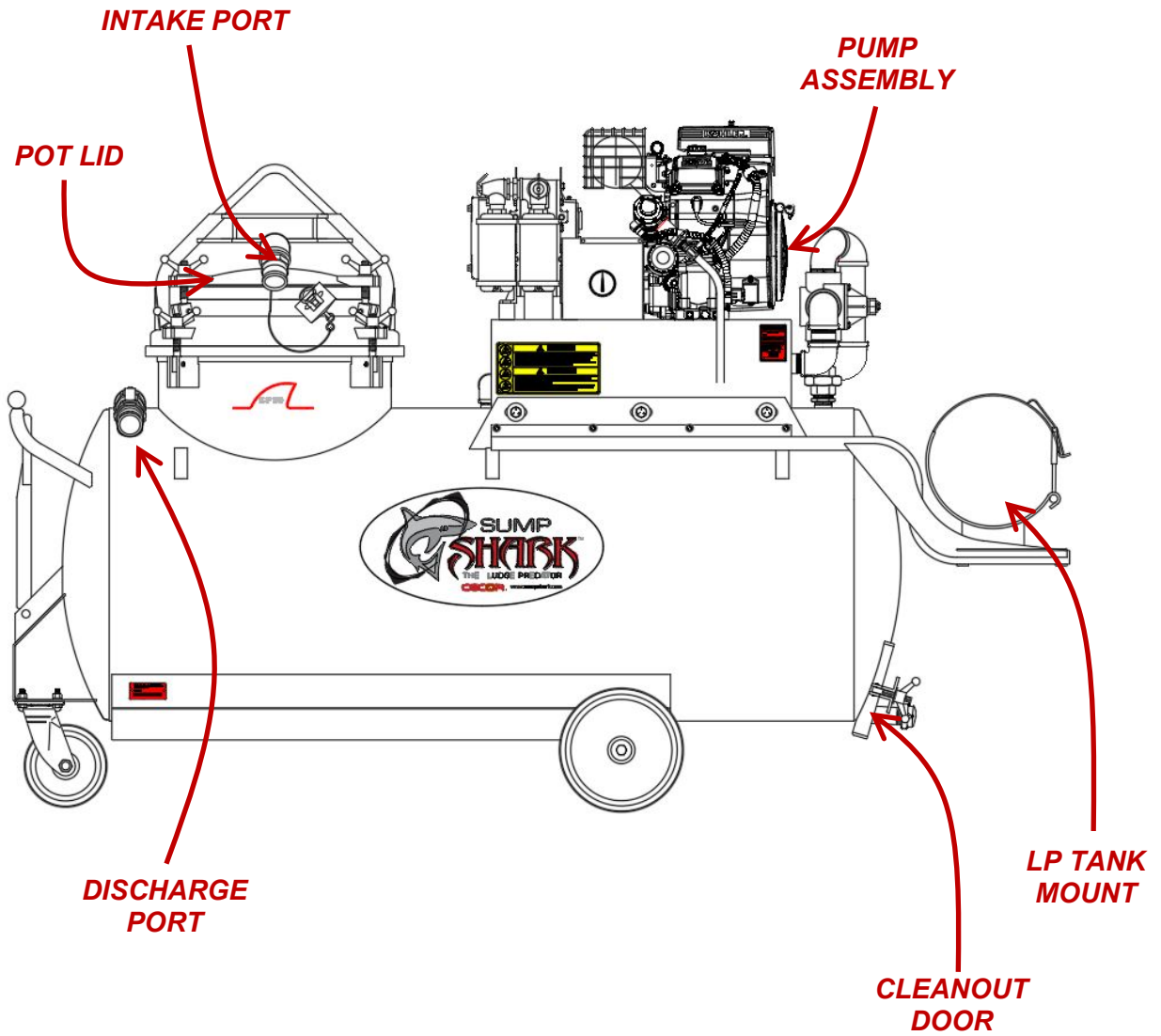



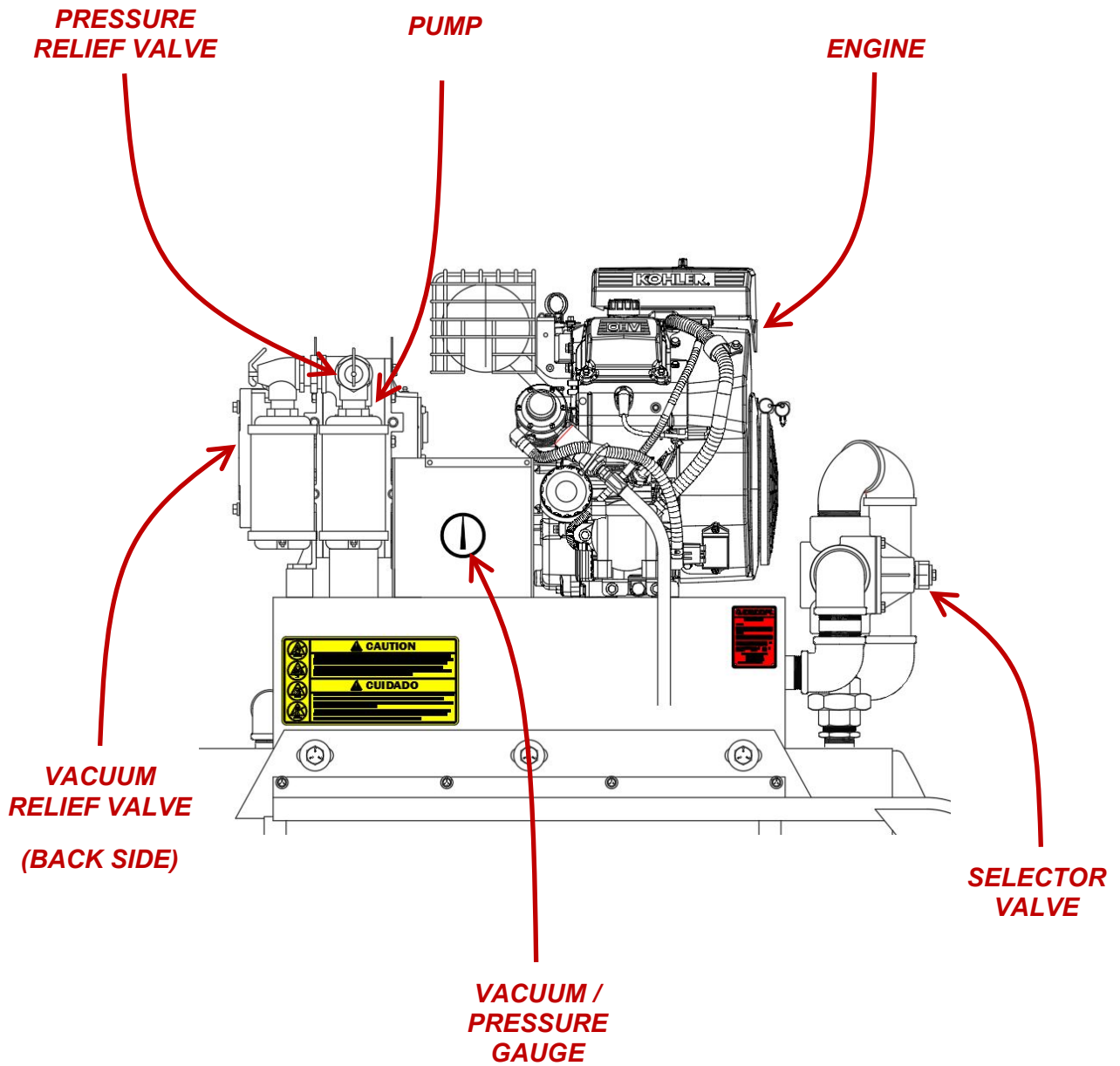

## SECTION 3 – INSTALLATION

### 3.1 – ASSEMBLE DISCHARGE CONNECTION

FOR SHIPPING PURPOSE, INSTALLATION OF THE DISCHARGE VALVE AND QUICK DISCONNECT ADAPTER IS REQUIRED. USE PIPE SEALANT ON ALL JOINTS AND TIGHTEN SECURELY.

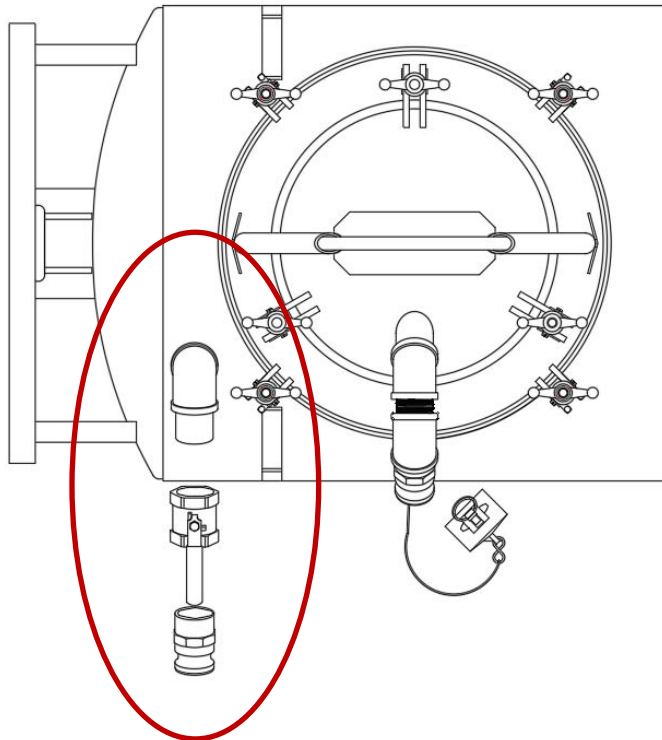

### 3.2 – LOOSE ITEMS

SOME ITEMS MAY BE PACKAGED IN A BOX LOCATED ON THE SHIPPING PALLET. PACKAGES WITH FILTER BASKET OR FILTER ASSEMBLIES WILL HAVE FILTERS INSTALLED. PLEASE REVIEW YOUR PACKING LIST TO SEE WHAT ADDITIONAL ITEMS YOU WILL BE RECEIVING.

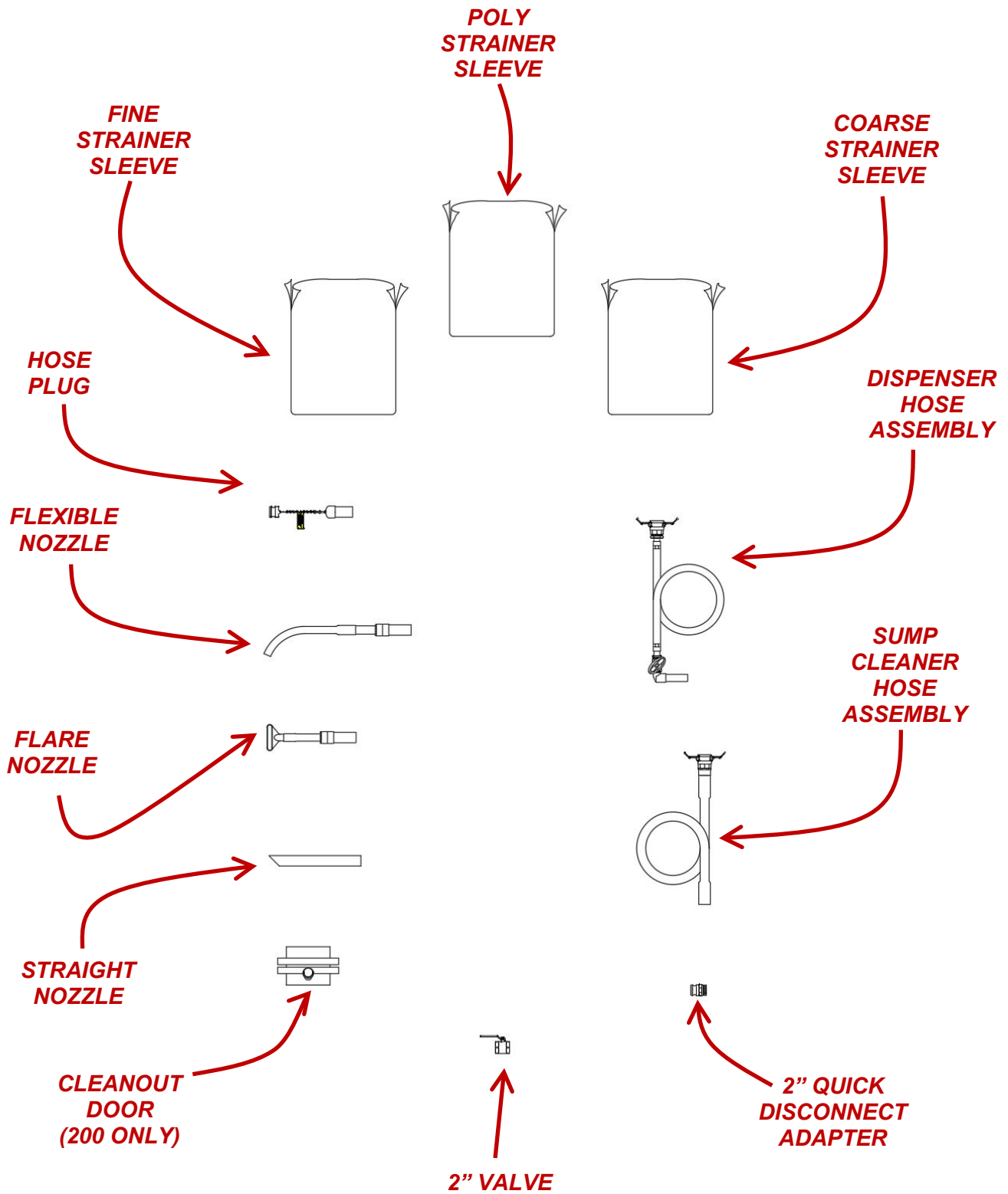

### 3.3 – INITIAL STARTUP

1. BEFORE USING THE SUMP CLEANER TO SERVICE SUMPS, RUN THE UNIT IN BOTH “SUCTION” AND “DISCHARGE” MODES.

#### 3.3.1 – SELECTOR VALVE

1. SETTING SELECTOR VALVE TO VENT TANK.

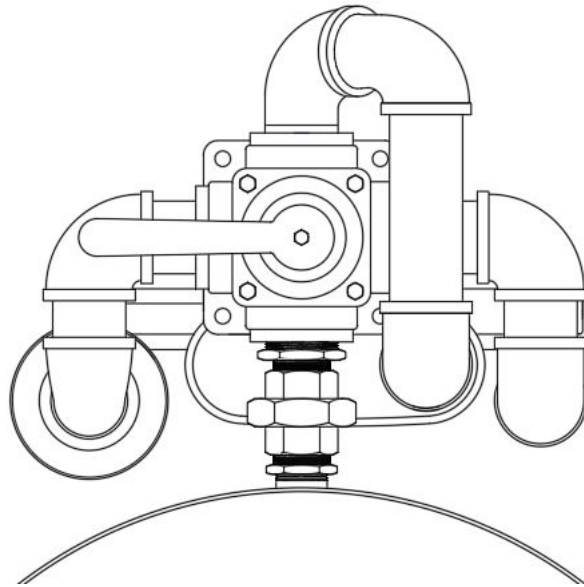

2. SETTING SELECTOR VALVE TO SUCTION.

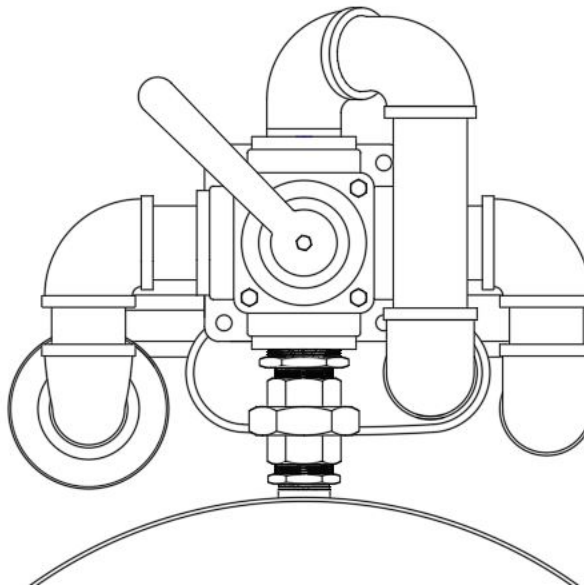

### 3. SETTING SELECTOR VALVE TO DISCHARGE.

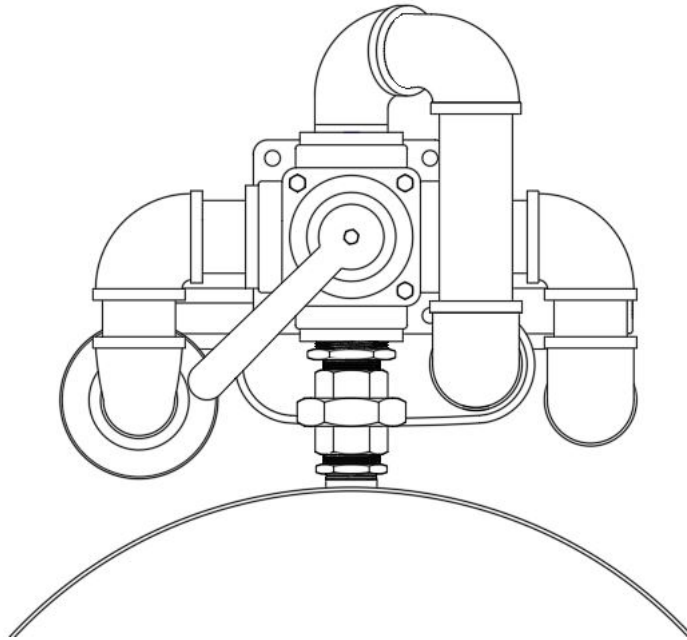

#### 3.3.2 – SECURE TANK PORTS

1. CLOSE AND SECURE ALL PORTS INCLUDING THE POT LID, CLEANOUT DOOR, INTAKE CAP, AND DISCHARGE.

#### 3.3.3 – STARTING ENGINE

1. TURN SELECTOR VALVE TO “VENT” POSITION.
2. OPEN LP TANK VALVE.
3. SET THROTTLE TO HALF AND CHOKE TO FULL

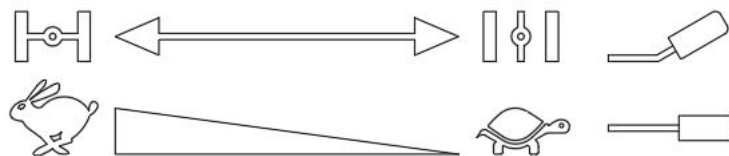

4. OPEN THE GAS VALVE LOCATED ON THE ENGINE.

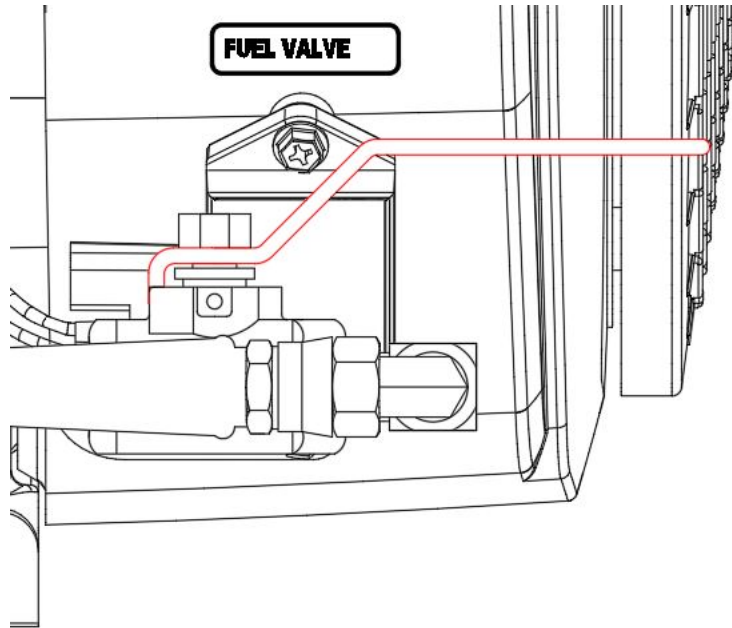

5. START ENGINE USING KEY IN IGNITION.

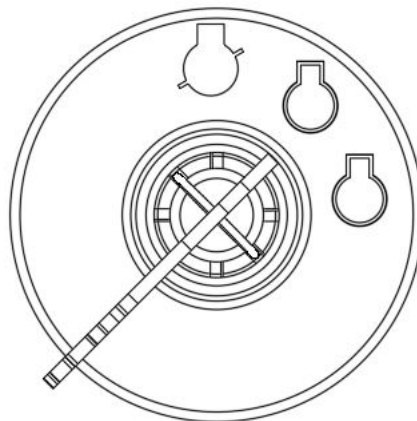

6. ONCE THE ENGINE IS STARTED AND RUNNING, REMOVE THE CHOKE.

### 3.3.4 – RUN UNIT IN “SUCTION”

1. TURN THE SELECTOR VALVE TO “VENT”.
2. CONNECT SUMP CLEANER HOSE TO INTAKE PIPE.
3. CLOSE DISCHARGE VALVE.
4. TURN THE SELECTOR VALVE TO “SUCTION”. VACUUM READING ON GAUGE LOCATED ON THE CONTROL PANEL WILL DECREASE AND STABILIZE AT 13 inHg.

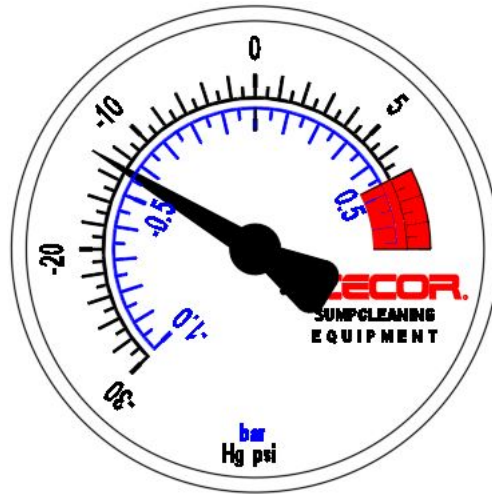

5. TURN THE SELECTOR VALVE TO “VENT” POSITION. PRESSURE WILL DECREASE TO 0 inHg.

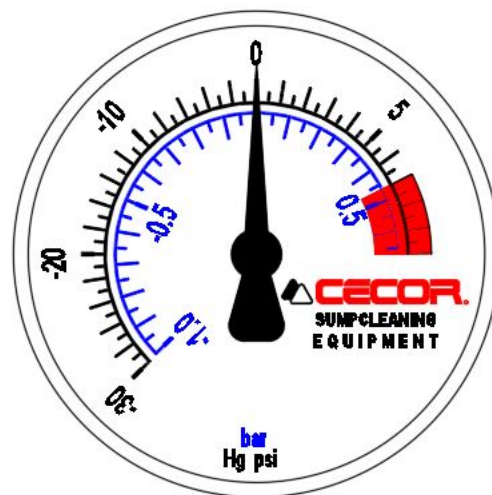

### 3.3.5 – RUN UNIT IN DISCHARGE

1. TURN THE SELECTOR VALVE TO “VENT”.
2. CONNECT SUMP CLEANER HOSE TO DISCHARGE PIPE.
3. INSTALL CAP TO INTAKE PIPE.
4. TURN THE SELECTOR VALVE TO “DISCHARGE”. VACUUM READING ON GAUGE LOCATED ON THE CONTROL PANEL WILL INCREASE AND STABILIZE AT 6 PSI.

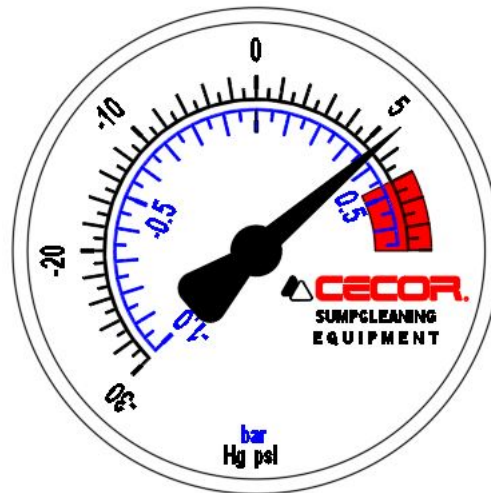

### 3.3.6 – SHUTTING ENGINE OFF

1. TURN FUEL VALVE TO FULLY CLOSED POSITION, ALLOWING ENGINE TO RUN OUT OF FUEL.
2. TURN KEY TO OFF POSITION. **(NOTE: SWITCHING KEY TO OFF POSITION PRIOR TO ALLOWING ENGINE TO RUN OUT OF FUEL MAY CAUSE ENGINE BACKFIRE ON RESTART.)**



## SECTION 4 – OPERATION

### 4.1 – CLEANING A SUMP

1. ATTACH THE SUMP CLEANER HOSE TO THE SUCTION PORT, AND INSERT SUCTION TOOL INTO HOSE END.

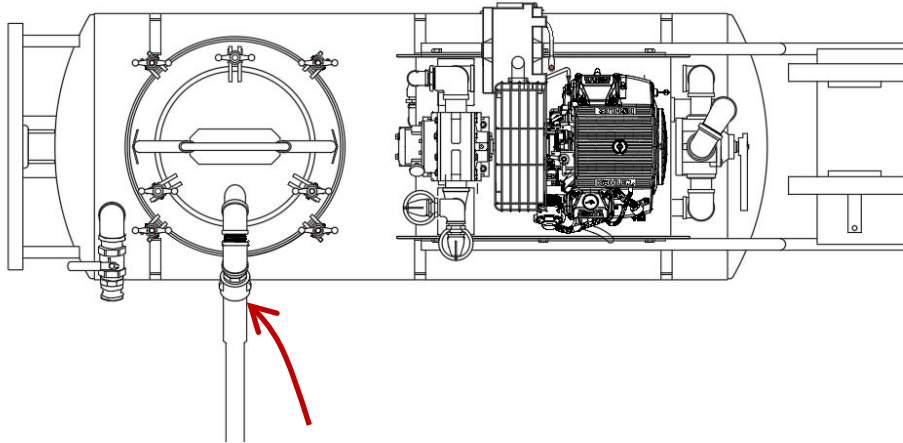

2. RUN UNIT ON SUCTION MODE. (SEE INITIAL STARTUP 3.3.4.)
3. WHEN VACUUMING OUT THE SUMP, ATTACK THE SOLIDS FIRST. POSITION THE SUCTION TOOL IN THE AREAS THAT ARE PRIMARILY SOLIDS. OCCASIONALLY MOVE THE SUCTION TOOL FROM THE SOLID PARTICULATE IN THE SUMP BOTTOM TO A PRIMARILY FLUIDIC AREA. THIS ACTION WILL CLEAR THE HOSE OF SOLIDS REDUCING THE CHANCES OF POSSIBLY PLUGGING THE HOSE.
4. WHEN THE TANK IS FULL, THE FLOAT CONTROL (LOCATED INSIDE THE SUMP CLEANER) WILL CUT OFF SUCTION TO THE PUMP ISOLATING THE PUMP FROM THE TANK (PUMP WILL KEEP RUNNING). WHEN THIS HAPPENS, THE VACUUM READING WILL FALL TO ZERO INDICATING THE TANK NEEDS TO BE EMPTIED.
5. WHEN THE FILTER IS FULL OR BLINDED, THE VACUUM/PRESSURE GAUGE WILL READ 10"± HG, BUT THERE WILL BE NO SUCTION AT THE NOZZLE INDICATING THE FILTER NEEDS TO BE EMPTIED.

## 4.2 – DISCHARGING FLUID FROM THE SUMP CLEANER

1. ATTACH THE SUMP CLEANER HOSE TO THE DISCHARGE PORT, AND CAP THE SUCTION PORT.

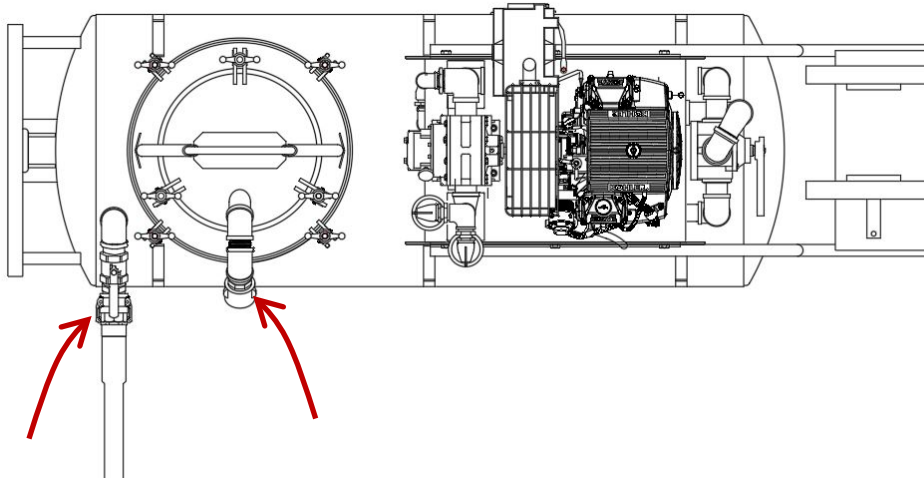

2. RUN UNIT ON DISCHARGE MODE. (SEE INITIAL STARTUP 3.5, STEP 6.)
3. POINT NOZZLE AT THE TARGET WHERE THE FLUID IS TO BE DISPENSED, SLOWLY OPEN DISCHARGE VALVE. SLUGS OF AIR WILL PASS THROUGH HOSE WHEN TANK APPROACHES EMPTY. THESE SLUGS CAN CAUSE ERRATIC FLUID FLOWS, BE PREPARED TO SHUT OFF DISCHARGE VALVE WHEN THIS OCCURS.

## 4.3 – FILTER

1. FILTERING OF THE FLUID IS SPECIFIC TO YOU. SUMP CONDITIONS VARY DUE TO ALL THE VARIABLES THAT OCCUR IN A MACHINE-TOOL SUMP. WE INCLUDE MULTIPLE FILTER BAGS SO YOU CAN FIND WHAT WORKS BEST FOR YOUR APPLICATION. FIRST-CLEANING CAN BE ESPECIALLY DIFFICULT IF IT HAS NOT BEEN DONE ON A REGULAR BASIS. WE SUGGEST STARTING WITH A COARSER BAG. ONCE ON A ROUTINE BASIS, A FINER FILTER CAN BE USED.
2. FILTERS ARE REUSABLE AND WASHABLE IN LUKEWARM WATER.

## 4.3.2 – F50 FILTER

### 4.3.2.1 – EMPTYING FILTER

1. FOR BEST RESULTS, DISCHARGE LIQUID FROM SUMP CLEANER AND LET FILTER DRAIN FOR A FEW MINUTES BEFORE DUMPING.
2. LOOSEN THE FOUR WING NUTS ON FILTER ASSEMBLY.

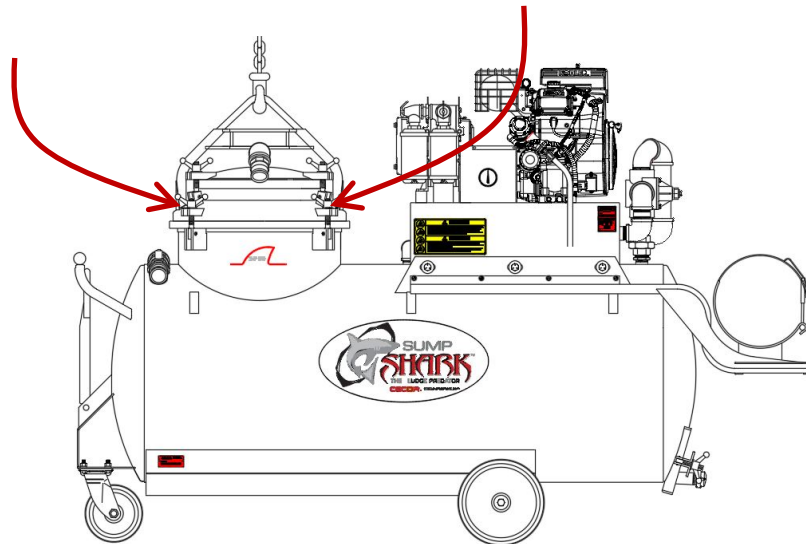

3. LIFT FILTER OUT OF SUMP CLEANER TANK USING HOIST OR FORKLIFT. CAUTION: KEEP HANDS AND FINGERS CLEAR OF POT OPENING IN SUMP CLEANER WHEN REMOVING FILTER!

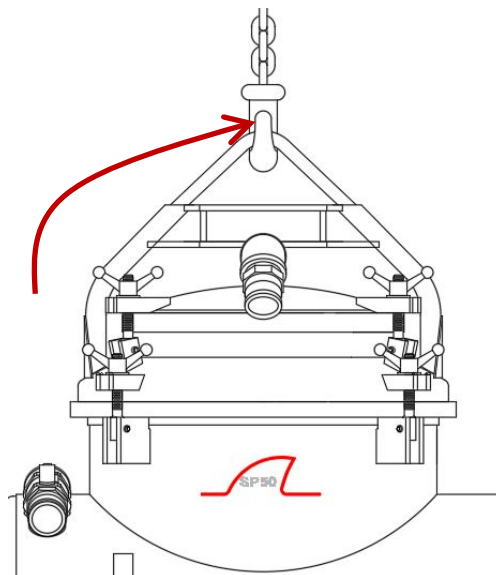

4. POSITION FILTER ABOVE CONTAINER INTO WHICH THE SLUDGE IS TO BE EMPTIED. DISTANCE BETWEEN BOTTOM OF FILTER AND CONTAINER BOTTOM OR "D" DIMENSION, SHOWN IN FIGURE BELOW, AND SHOULD BE APPROXIMATELY 2 TO 3 FEET ON F50 TO PREVENT DAMAGE TO FILTER SLEEVE WHEN DUMPED. DRAINING FILTER BEFORE POSITIONING AND USING A CONTAINER WITH A DRY BOTTOM AND SUITABLE CAPACITY WILL HELP REDUCE POSSIBLE FILTER SPLASH BACK.

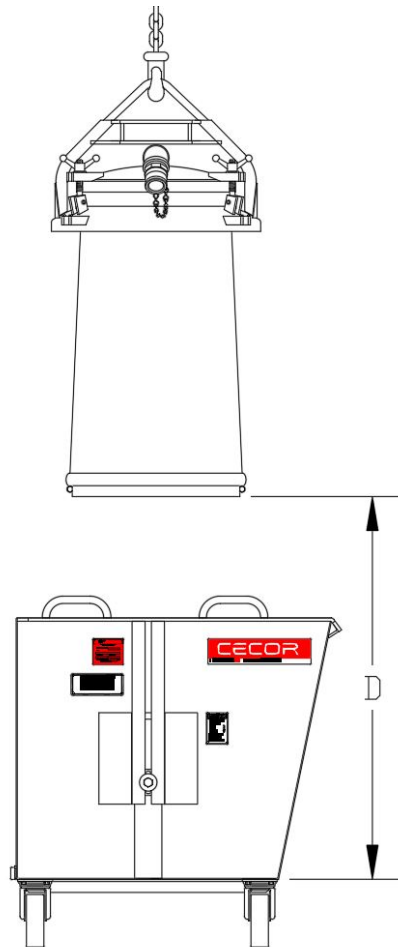

5. ATTACH LANYARD TO TRIGGER ASSEMBLY ON FILTER BOTTOM.

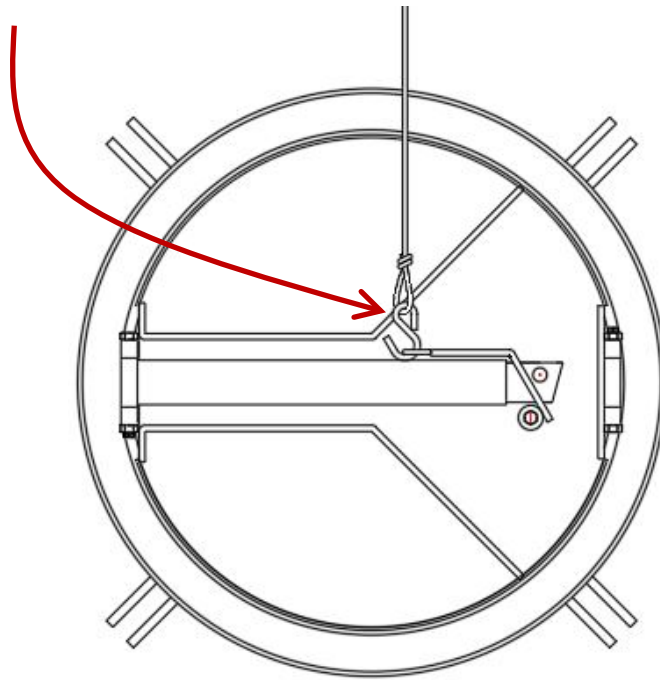

6. MOVE TO A SAFE DISTANCE FROM THE DUMPING ZONE (APPROXIMATELY 7 FEET).
7. PULL LANYARD TO RELEASE LATCH AND BOTTOM DOOR WILL OPEN DUMPING THE FILTER.
8. AFTER FILTER SLEEVE IS EMPTY, ROLL BOTTOM OF SLEEVE UP LOOSELY SO THAT THE BOTTOM END OF SLEEVE WILL BE CLOSED AND CLOSE BOTTOM DOOR.

#### 4.3.2.2 – INSTALLING FILTER

1. LOOSEN THE THREE WING NUTS ON THE FILTER LID AND REMOVE LID.

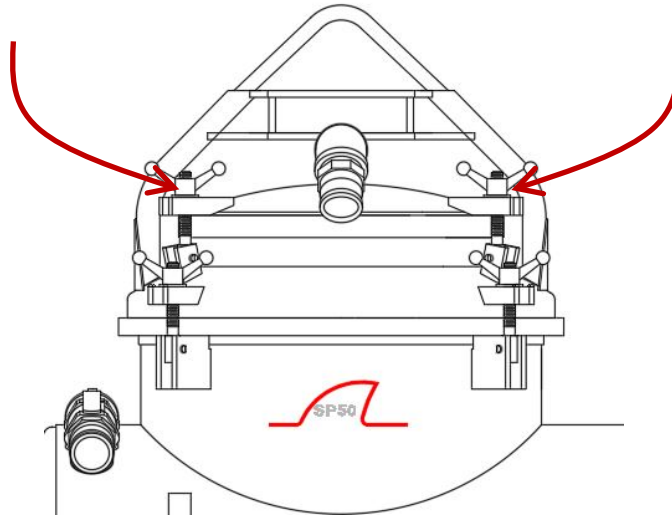

2. PLACE BOTTOM END OF FILTER SLEEVE IN FILTER.
3. FOLD UPPER 1 ½" OF FILTER SLEEVE COLLAR OUT OVER LIP OF FILTER SO THAT THE GASKET IN LID WILL CLAMP IT IN PLACE.
4. REPLACE FILTER LID AND TIGHTEN WING NUTS SECURELY.
5. SUSPEND FILTER FROM HOIST OR FORKLIFT. OPEN FILTER DOOR.
6. PULL BOTTOM END OF FILTER SLEEVE DOWN AND FOLD UP LOOSELY SO THAT BOTTOM END OF SLEEVE WILL BE CLOSED.
7. PLACE FILTER IN SUMP CLEANER AND TIGHTEN THE WING NUTS SECURELY.

#### 4.4 – CLEANING THE SUMP CLEANER

1. GENERALLY, DISCHARGING THE FLUID OUT OF THE SUMP CLEANER IS ALL THAT'S NEEDED. SOME SOLIDS WILL ACCUMULATE IN THE BOTTOM OF THE SUMP AND WILL REQUIRE A COMPLETE CLEANOUT OCCASIONALLY.
2. THE SA5 HAS AN EASY TO REMOVE CLEANOUT DOOR AND CAN ACCESSED BY LOOSENING THE TWO WINGNUTS.

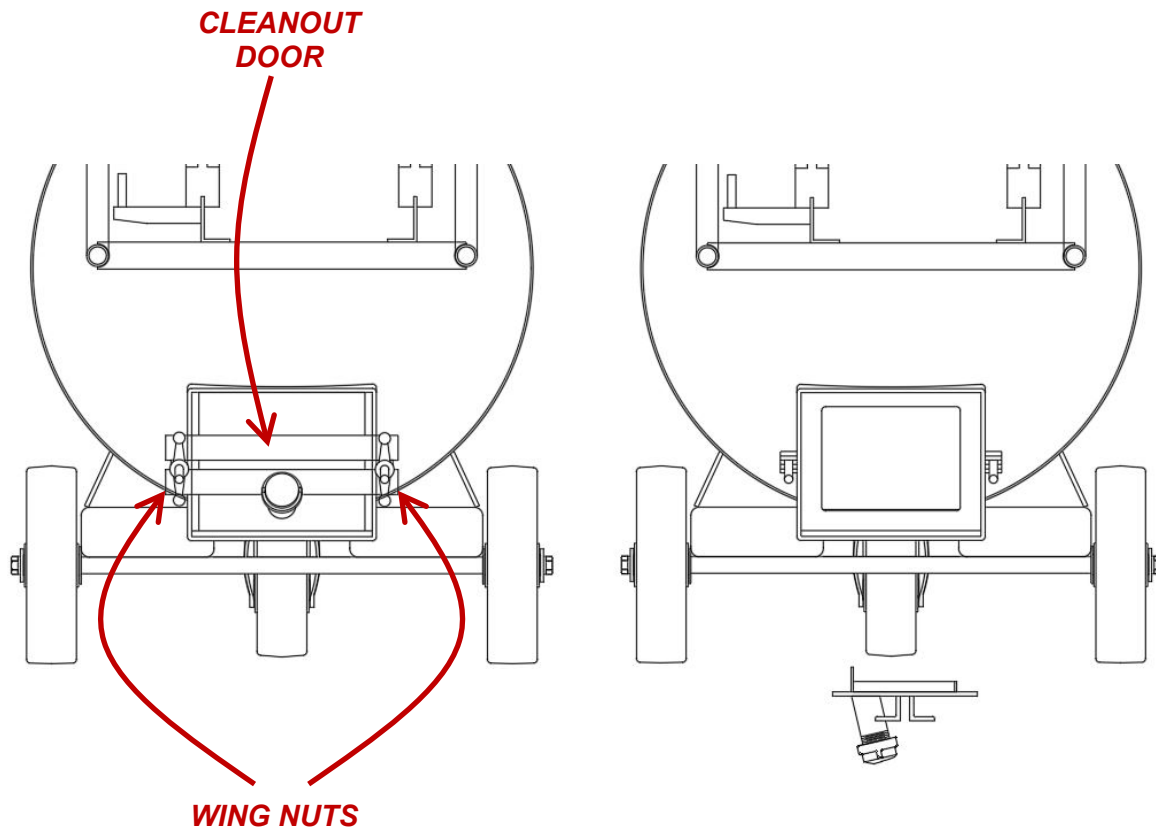

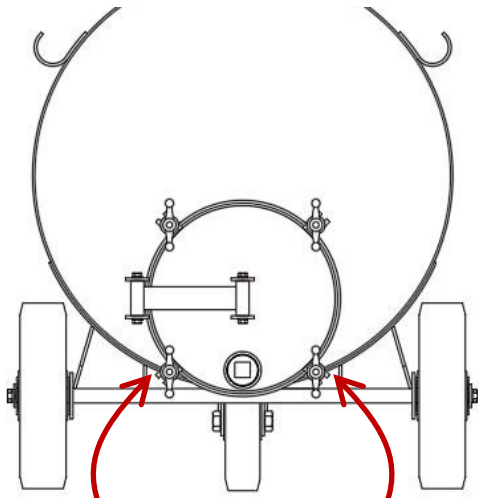

**WING NUTS**

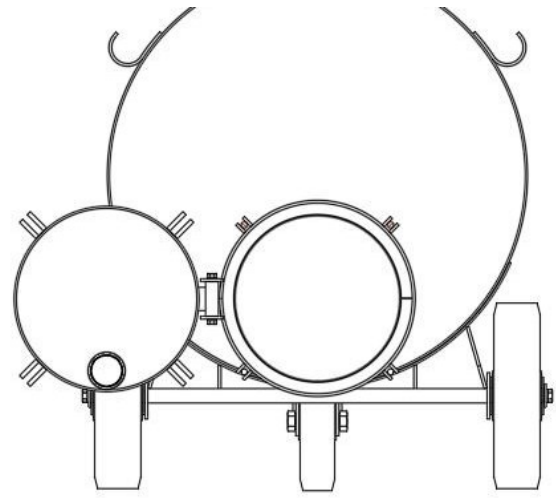



## SECTION 5 – MAINTENANCE

TO GET THE HIGHEST PERFORMANCE FROM YOUR SUMP SHARK, IT IS IMPORTANT TO KEEP IT WELL MAINTAINED. BELOW IS A MAINTENANCE GUIDE THAT WILL KEEP YOUR SUMP CLEANER IN TOP-NOTCH, DEPENDABLE CONDITION. ANY WORN OR DAMAGED PART SHOULD BE REPLACED IMMEDIATELY. CECOR STOCKS SUMP CLEANER PARTS AND MOST CAN BE SHIPPED THE SAME OR THE NEXT DAY. CALL 1-800-356-9042 TO ORDER PARTS.

### 5.1 – DAILY MAINTENANCE

1. CHECK THE VACUUM/PRESSURE GAUGE TO SEE THAT IT IS OPERATING AND READING CORRECTLY. TANK PRESSURE SHOULD NOT EXCEED PRESSURES OF 7 PSI. VACUUM SHOULD NOT EXCEED 13 inHg.
2. DEFECTIVE RELIEF VALVES SHOULD BE REPLACED IMMEDIATELY.
3. CHECK FOR GASKET LEAKS AND ANY TANK DAMAGE.

### 5.2 – WEEKLY MAINTENANCE

1. INSPECT TANK FOR SLUDGE BUILD UP. CLEAN TANK IF NECESSARY. WITH SOME APPLICATIONS, THE TANK MAY NEED TO BE CLEANED MORE FREQUENTLY. ALWAYS CLEAN THE TANK BETWEEN PUMPING DIFFERENT TYPES OF FLUIDS OR MATERIALS.
2. CLEAN AND INSPECT TANK FLOAT CONTROL. SEE THAT THE FLOAT BALL SEALS AGAINST THE GASKET. THE FLOAT CONTROL ASSEMBLY CAN BE ACCESSED THROUGH THE POT OPENING IN THE SUMP CLEANER.
3. CLEAN THE FILTER BAG BY RINSING IT OUT IN LUKEWARM WATER.
4. OPERATE THE PRESSURE RELIEF HANDLE TO MAKE SURE IT IS WORKING.

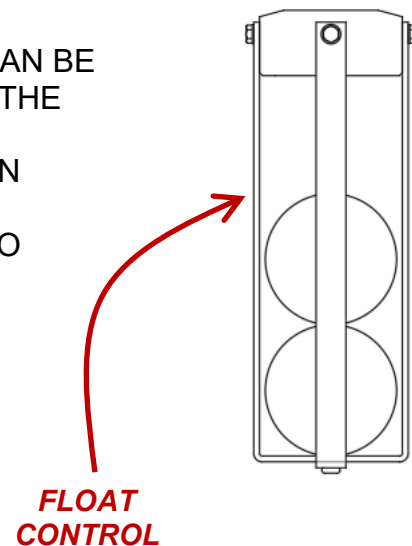

### **5.3 – MONTHLY MAINTENANCE**

1. CHECK FOR WEAR ON POT LID WING NUTS AND STUDS.
2. INSPECT SUMP CLEANER HOSE.
3. GREASE THE SWIVEL CASTER AND WHEELS.

## SECTION 6 – TROUBLESHOOTING

### 6.1 – SUCTION

**PROBLEM: THERE IS NO SUCTION WHILE...**

1. THE SUCTION PORT IS CAPPED AND DISCHARGE VALVE IS CLOSED
2. THE VACUUM / PRESSURE GAUGE READS "0" SUCTION WITH THE SELECTOR VALVE IN THE SUCTION POSITION
3. **AND** AIR IS COMING OUT OF THE MUFFLER

**POSSIBLE CAUSE:**

TANK IS FULL  
THE DISCHARGE VALVE IS OPEN  
THE FLOAT CONTROL IS HUNG-UP

**SOLUTION:**

DISCHARGE THE FLUID OUT OF THE TANK  
CLOSE THE DISCHARGE VALVE AND PROCEED  
CLEAN THE FLOAT CONTROL

**PROBLEM: THERE IS NO SUCTION WHILE...**

1. THE SUCTION PORT IS CAPPED AND DISCHARGE VALVE IS CLOSED
2. THE VACUUM / PRESSURE GAUGE READS "GREATER THAN 10" WITH THE SELECTOR VALVE IN THE SUCTION POSITION
3. **AND** AIR IS COMING OUT OF THE MUFFLER

**POSSIBLE CAUSE:**

THE FILTER IS FULL OR BLINDED  
THE SUCTION HOSE IS PLUGGED

**SOLUTION:**

EMPTY THE FILTER  
CLEAN OUT THE HOSE

**PROBLEM: THERE IS STILL NO SUCTION.**

1. RUN UNIT ON "SUCTION" THEN "PRESSURE". IF THE VACUUM / PRESSURE GAUGE READS "0" IN BOTH INSTANCES, THE PROBLEM COULD BE ONE OF THE FOLLOWING:

**POSSIBLE CAUSE:**

THE SELECTOR VALVE  
THE TANK PORT IS OPEN

**SOLUTION:**

INTERNALLY CLEAN AND LUBRICATE SELECTOR VALVE  
RUN THE UNIT ON PRESSURE AND CHECK FOR LEAKS / UNSECURED PORTS

## 6.2 – DISCHARGE

<b>PROBLEM: UNABLE TO DISCHARGE TANK CONTENTS WHEN...</b>	
<ol style="list-style-type: none"> <li>1. THE SUCTION PORT IS CAPPED AND DISCHARGE VALVE IS CLOSED</li> <li>2. UNDER PRESSURE, VACUUM / PRESSURE GAUGE READS “6” PSI</li> <li>3. UNDER VACUUM, VACUUM / PRESSURE GAUGE READS OVER “10” inHg</li> </ol>	
<b>POSSIBLE CAUSE:</b>	<b>SOLUTION:</b>
THE TANK DISCHARGE VALVE IS CLOSED	OPEN THE DISCHARGE VALVE
THE DISCHARGE HOSE IS PLUGGED	UNPLUG THE HOSE BY BENDING THE HOSE IN THE PLUG AREA WHILE THE SUMP CLEANER IS UNDER VACUUM
DISCHARGE HOSE IS KINKED	REPLACE THE HOSE
DISCHARGE PIPE IS PLUGGED	CLEANOUT TANK

<b>PROBLEM: UNABLE TO DISCHARGE TANK CONTENTS WHEN...</b>	
<ol style="list-style-type: none"> <li>1. THE SUCTION PORT IS CAPPED AND DISCHARGE VALVE IS CLOSED</li> <li>2. UNDER PRESSURE, VACUUM / PRESSURE GAUGE READS “0” PSI</li> <li>3. UNDER VACUUM, VACUUM / PRESSURE GAUGE READS OVER “10” inHg</li> </ol>	
<b>POSSIBLE CAUSE:</b>	<b>SOLUTION:</b>
THE PRESSURE RELIEF VALVE MAY HAVE FAILED. SHOULD NOT FLOW OUT OF THE RELIEF AT PRESSURES UNDER 6 PSI	REPLACE RELIEF VALVE
WORN GASKET	REPLACE WORN GASKET

<b>PROBLEM: STILL UNABLE TO DISCHARGE.</b>	
<ol style="list-style-type: none"> <li>1. RUN UNIT ON “SUCTION” THEN “PRESSURE”. IF THE VACUUM / PRESSURE GAUGE READS “0” IN BOTH INSTANCES, THE PROBLEM COULD BE ONE OF THE FOLLOWING:</li> </ol>	
<b>POSSIBLE CAUSE:</b>	<b>SOLUTION:</b>
THE SELECTOR VALVE	INTERNALLY CLEAN AND LUBRICATE SELECTOR VALVE
THE TANK PORT IS OPEN	RUN THE UNIT ON PRESSURE AND CHECK FOR LEAKS / UNSECURED PORTS

## 6.3 – MUFFLER LEAKING FLUID

<b>PROBLEM: FLUID IS COMING OUT OF THE MUFFLER</b>	
<b>POSSIBLE CAUSE:</b>	<b>SOLUTION:</b>
FLOAT CONTROL IS ALLOWING FLUID TO BYPASS	INSPECT FLOAT CONTROL. CLEAN OR REPLACE
EXCESSIVE COOLANT FOAMING	CONSULT COOLANT SUPPLIER
EXCESSIVE TURBULANCE IN THE TANK	CHECK TO SEE IF AIR IS BEING SUCKED INTO THE DISCHARGE PIPE
QUICKLY SWITCHING THE SELECTOR VALVE FROM “SUCTION” TO “DISCHARGE” THEN BACK WHEN TANK IS FULL	ALLOW TANK TO STABILIZE IN ONE MODE OF OPERATION BEFORE SWITCHING TO ANOTHER MODE OF OPERATION

## SECTION 7 – REPAIR PARTS LIST

### 7.1 – WHEELS & CASTER

#### 7.1.1 “PTL” PUSH TOW WHEEL TRANSPORT 200 GAL

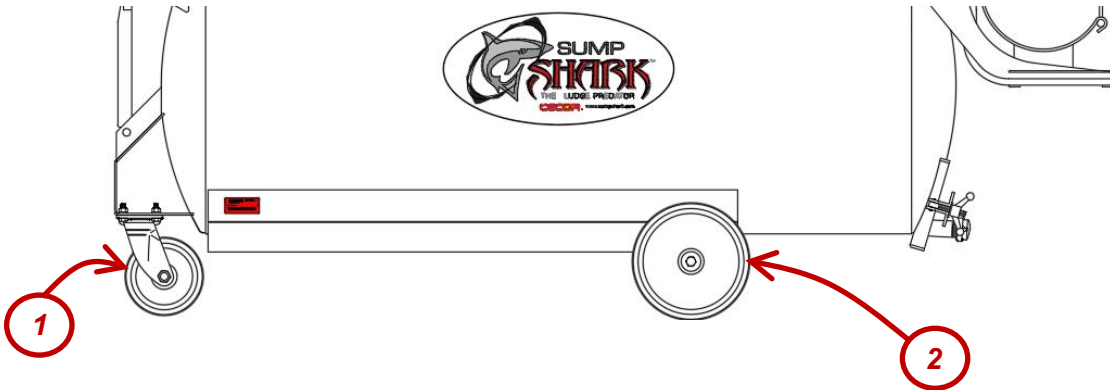

Ref	Part No.	Description
1	SP-365	SWIVEL CASTER WITH POLY TIRED WHEEL 8" DIA
2	SP-553	WHEEL POLY TIRED 12" DIA

### 7.1.3 "TW" TOW WHEEL TRANSPORT 300 & 400 GAL

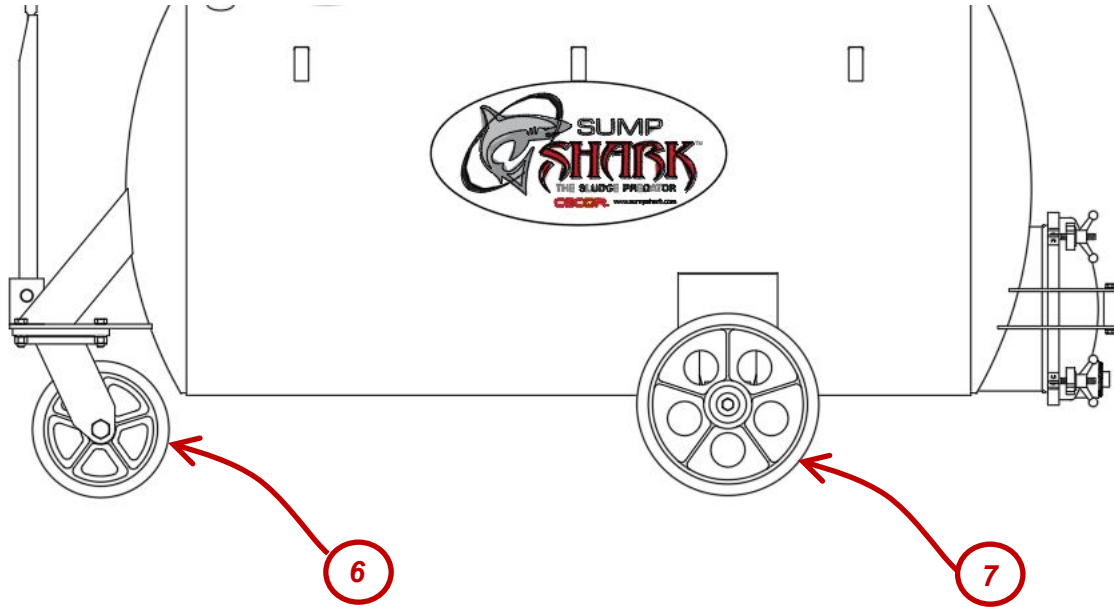

Ref	Part No.	Description
6	SP-270	SWIVEL CASTER WITH RUBBER TIRE 12" x 3"
7	SP-271	WHEEL WITH RUBBER TIRE 16" x 4"

### 7.1.4 "TW" TOW WHEEL TRANSPORT 500 GAL

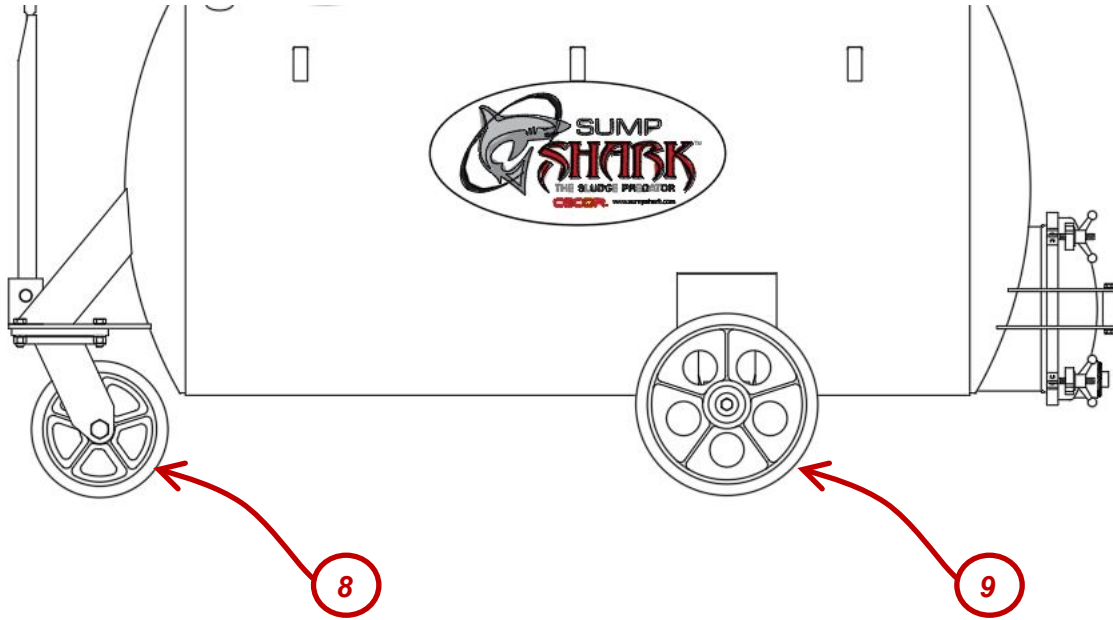

Ref	Part No.	Description
8	SP-270	SWIVEL CASTER WITH RUBBER TIRE 12" x 3"
9	SP-275	WHEEL WITH RUBBER TIRE 16" x 5"

## 7.2 – TANK

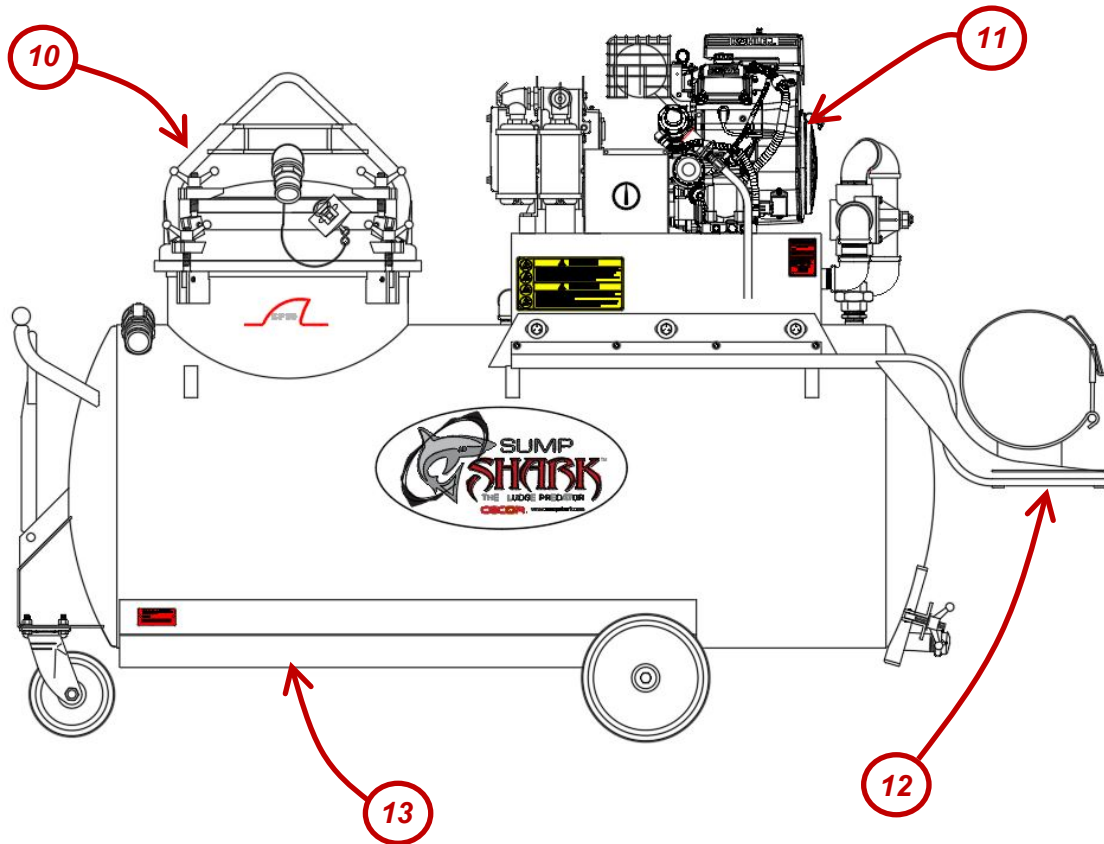

Ref	Part No.	Description
10	F50	F50 FILTER ASSEMBLY
11	A220-904	SP50 PUMP ASSEMBLY
12	A220-911	LP TANK ASSEMBLY
13	CALL FOR INFO	TANK ASSEMBLY



### 7.3 – SP50 PUMP

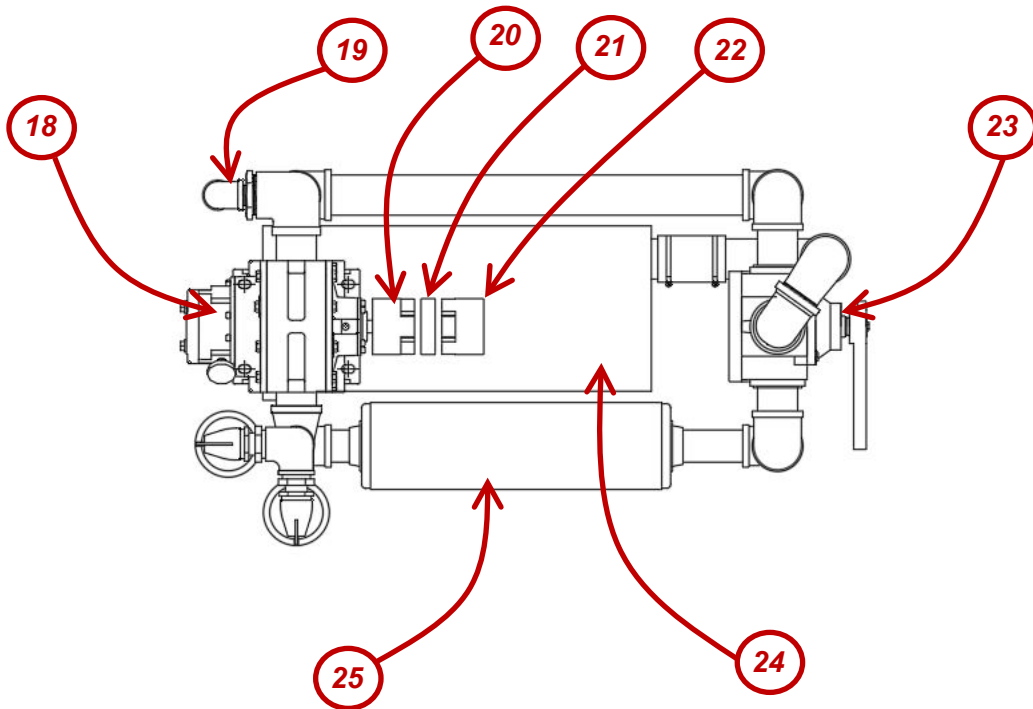
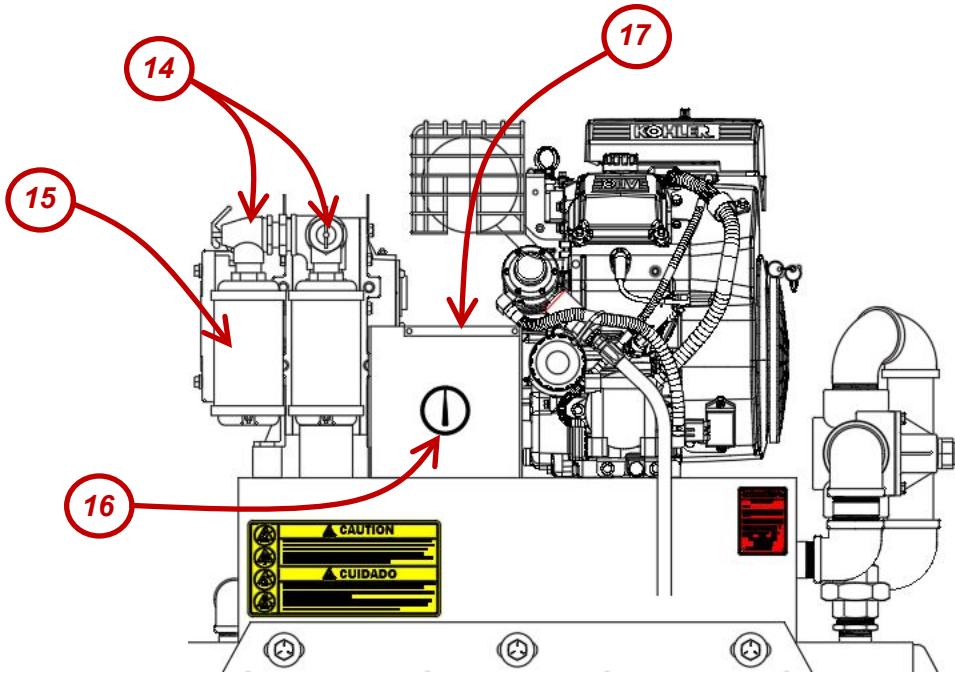

<b>Ref</b>	<b>Part No.</b>	<b>Description</b>
14	SP-443	PRESSURE RELIEF VALVE, 1", 7 PSI
15	SP-442	MUFFLER, 1"
16	SP-195	VACUUM / PRESSURE GAUGE
17	A220-707	HOOD
18	SP-388	VACUUM PUMP
19	SP-506	VACUUM RELIEF VALVE, 1"
20	SP--528	FLEXIBLE COUPLING BODY, 3/4" BORE
21	SP-529	FLEXIBLE COUPLING SPIDER
22	SP-515	FLEXIBLE COUPLING BODY, 1" BORE
23	SP-444	4-WAY SELECTOR VALVE
24	SP-441	MUFFLER, 2"
25	SP-538	MUFFLER, 1 1/2"

## 7.4 – F50 FILTER

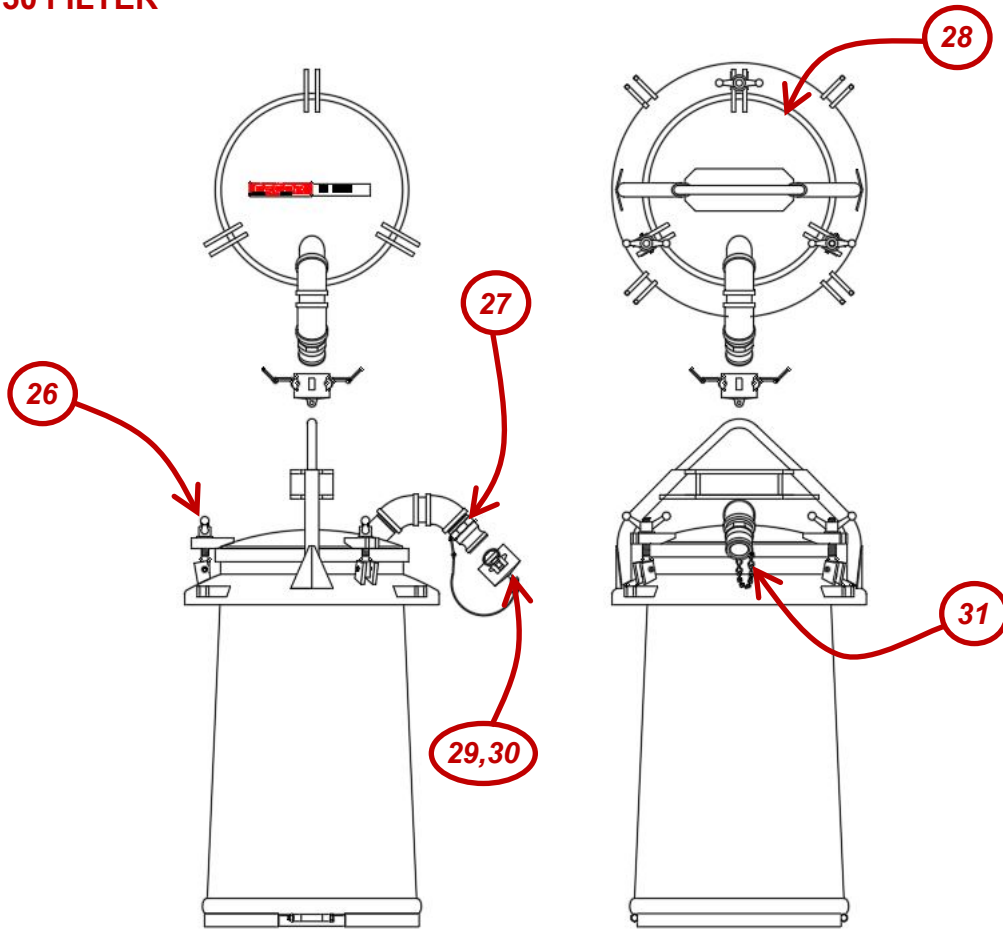

Ref	Part No.	Description
26	SP-386	WING NUT 5/8-11
27	SP-612	PRESSURE SAFE ADAPTER, 2" MALE
28	A220-274	FILTER LID GASKET
29	SP-262BN-2	COUPLER, GASKET, 2"
30	SP-611	PRESSURE SAFE CAP, 2"
31	SP-373	SECURITY CHAIN

## 7.5 – TANK CONNECTIONS & CONSUMABLES

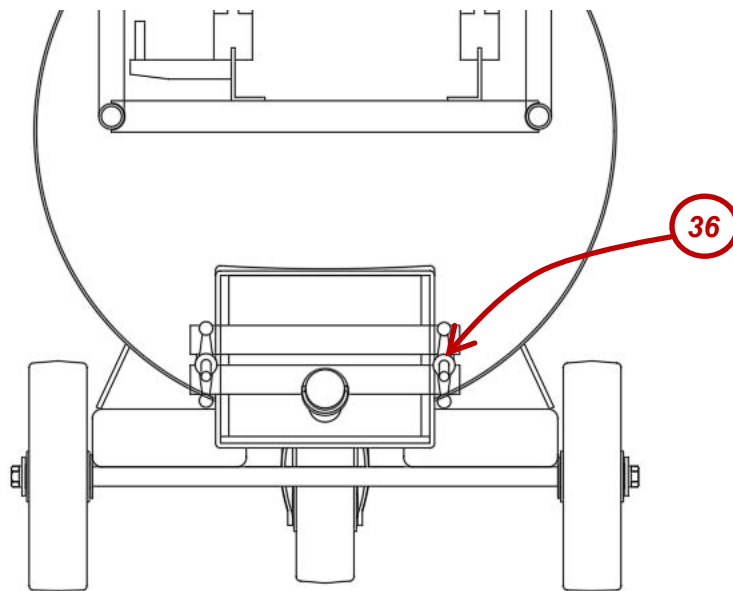
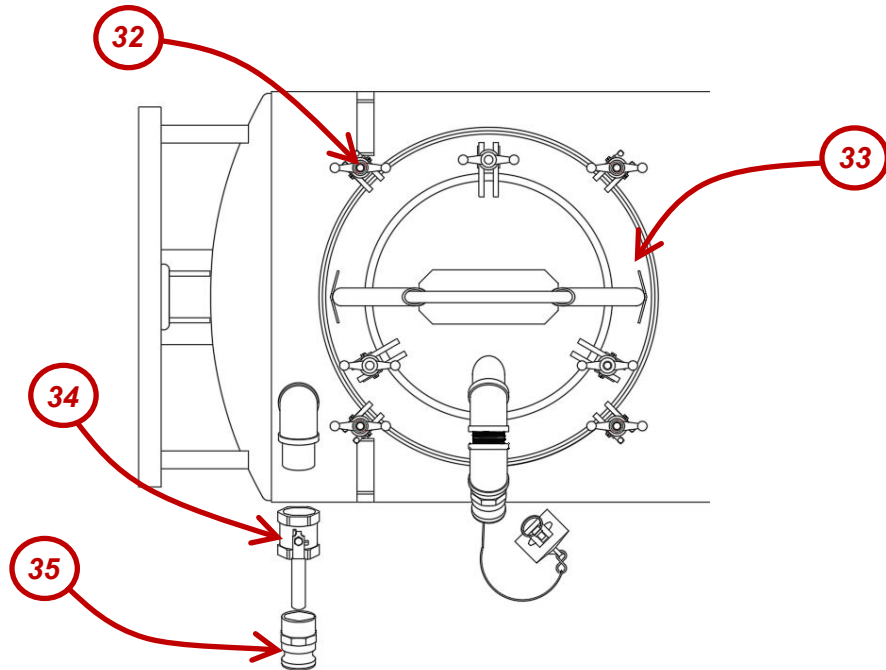

<b>Ref</b>	<b>Part No.</b>	<b>Description</b>
32	SP-386	WING NUT 5/8"-11
33	A220-276	POT LID GASKET 24"
34	SP-466	DISCHARGE VALVE, 2"
35	SP-375	DISCONNECT ADAPTER, 2" MALE
36	SP-104	WING NUT 1/2"-13

**200 ONLY**

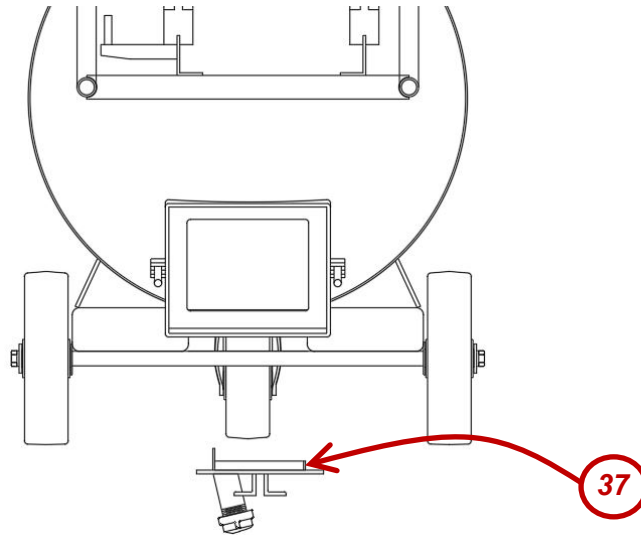

<b>Ref</b>	<b>Part No.</b>	<b>Description</b>
37	A210-165	CLEANOUT DOOR GASKET

**300-600 ONLY**

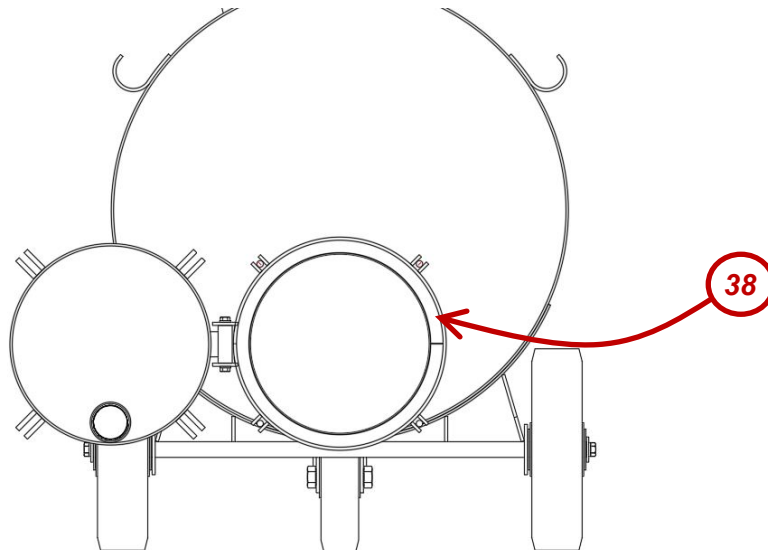

<b>Ref</b>	<b>Part No.</b>	<b>Description</b>
38	A210-305	POT LID GASKET 16"

## 7.6 – FILTER, TOOLS & HOSE

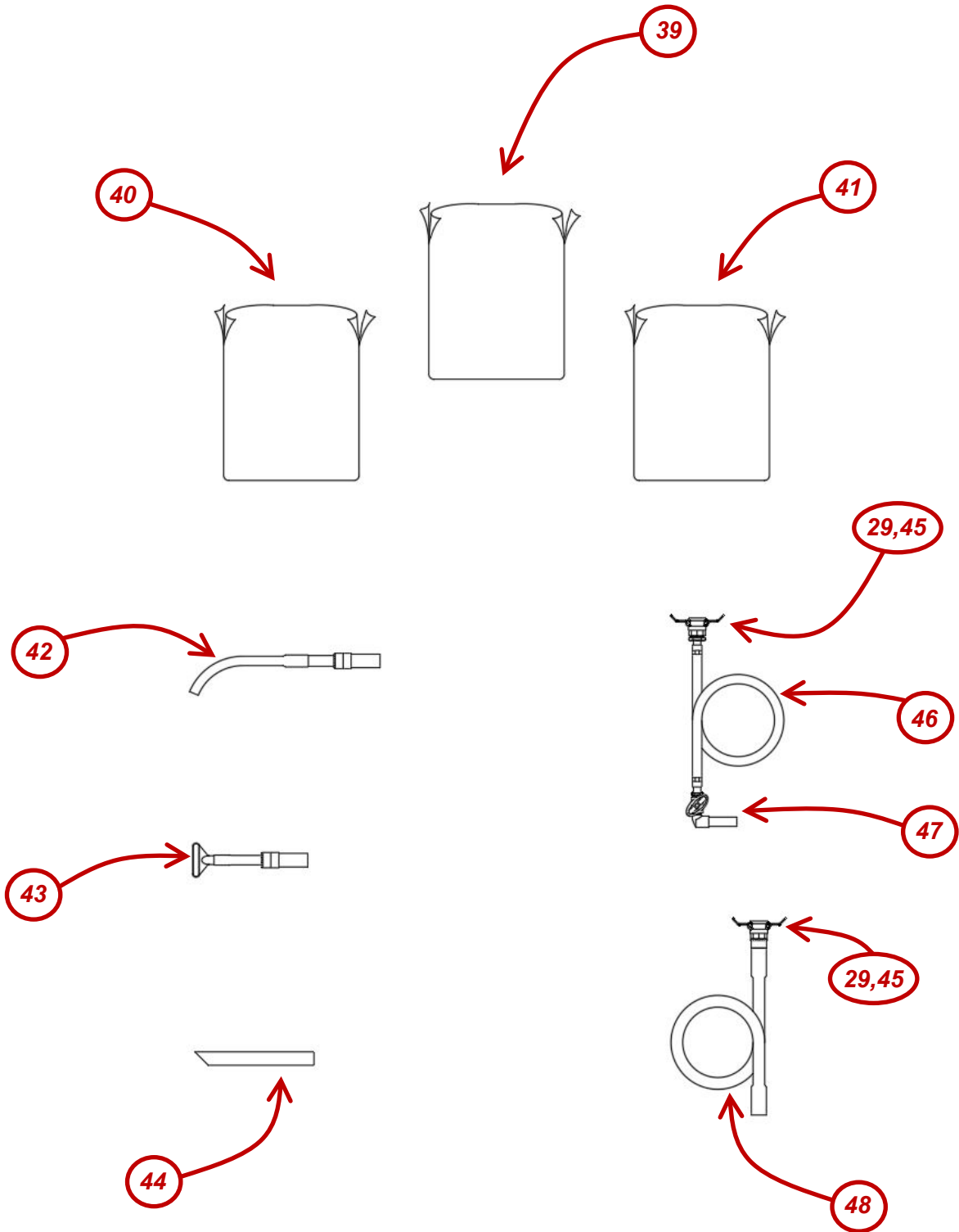

<b>Ref</b>	<b>Part No.</b>	<b>Description</b>
39	A220-336	POLY STRAINER BAG
40	A220-740	COARSE STRAINER BAG
41	A220-739	FINE STRAINER BAG
42	A220-152	FLEX NOZZLE
43	A220-151	FLARE NOZZLE
44	A210-965	STRAIGHT NOZZLE
45	SP-198-2	QUICK DISCONNECT COUPLER
46	A220-145	DISPENSER HOSE
47	A220-562	NOZZLE DISPENSER ASSEMBLY
48	A220-147	SUMP CLEANER HOSE



## **SECTION 8 – WARRANTY**

### **WARRANTY STATEMENT**

**PLEASE PRINT OUR WARRANTY AT [HTTPS://CECOR.NET/CECOR-WARRANTY/](https://cecor.net/cecor-warranty/)**

**SECTION 9 – RECORD MODEL & SERIAL NUMBER**

WHEN YOU RECEIVE YOUR CECOR SUMP SHARK, RECORD THE MODEL NUMBER, SERIAL NUMBER AND DATE DELIVERED FOR YOUR RECORDS.

<p><b>MODEL #:</b> _____</p> <p><b>SERIAL #:</b> _____</p> <p><b>DELIVERED:</b> _____ / _____ / _____</p>
---

# CECOR®

