

CECOR®

OPERATION MANUAL & PARTS LIST

SA3-DT



TABLE OF CONTENTS

SECTION 1 – SAFETY INFORMATION	3
1.1 – CAUTION	3
1.2 – PRECAUTIONS	4
SECTION 2 – THE SUMP CLEANER	5
2.1 – UNIT IDENTIFICATION	5
2.2 – MODEL & SERIAL NUMBER	6
2.3 – DRUM TOP FEATURES	6
SECTION 3 – INSTALLATION	9
3.1 – ASSEMBLE FLOAT CONTROL.....	9
3.2 – LOOSE ITEMS.....	9
3.3 – AIR SUPPLY CONNECTION	11
SECTION 4 – OPERATION	12
4.1 – SETTING UP DRUM TOP	12
SECTION 5 – MAINTENANCE	14
5.1 – DAILY MAINTENANCE.....	14
5.2 – WEEKLY MAINTENANCE.....	14
5.3 – MONTHLY MAINTENANCE	14
SECTION 6 – TROUBLESHOOTING	15
SECTION 7 – REPAIR PARTS LIST	16
SECTION 8 – ACCESSORIES.....	19
SECTION 9 – WARRANTY.....	20
SECTION 10 – RECORD MODEL & SERIAL NUMBER.....	21

SECTION 1 – SAFETY INFORMATION

1.1 – CAUTION

 FLAMMABLE INFLAMMABLE  TOXIC TÓXICO  CORROSIVE CORROSIVO  REACTIVE REACTIVIDAD	 CAUTION
	THIS EQUIPMENT IS INTENDED FOR USE WITH STANDARD METALWORKING FLUIDS (WATER-BASE & CUTTING OILS) ONLY. IT SHOULD NOT BE USED WITH FLAMMABLE FLUIDS, (FUELS, PAINT, SOLVENTS, ETC.) CORROSIVE, TOXIC OR REACTIVE MATERIALS. DO NOT USE IN EXTRA-HIGH TEMPERATURE OR SPARK-HAZARD ENVIRONMENTS (OVENS WELDING AREAS, ETC.). CLEAN TANK THOROUGHLY ON A FREQUENT BASIS, ESPECIALLY WHEN PUMPING DIFFERENT TYPES OF COOLANTS AND SOLIDS OF DIFFERENT MATERIAL. WE RECOMMEND SEPARATE TANK UNITS FOR DIFFERENT SERVICES AND SEGREGATED HANDLING OF DIFFERENT COOLANTS.
	 CUIDADO
	ESTE EQUIPO ES PARA USO CON FLUIDOS REGULARES DE CORTE (BASE AGUA Y ACEITES DE CORTS) EXCLUSIVAMENTE. NO SE DEBE USAR CON LÍQUIDOS INFLAMABLES, (COMBUSTIBLES, PINTURA, DISOLVENTES, ETC.). MATERIALES CORROSIVOS, TÓXICOS O REACTIVOS. NO UTILIZAR EN AMBIENTES DE TEMPERATURAS ALTAS O DONDE HAY RIESGO DE CHISPAS PELIGROSAS (HORNO, AREAS DE SOLDADURA, ECT.). LIMPIA A FONDO EL TANQUE DE MANERA FRECUENTE, ESPECIALMENTE CUANDO BOMBEE TIPOS DIFERENTES DE FLUIDO DE CORTE Y SÓLIDOS DE MATERIAL DISTINTO . RECOMENDAMOS UNIDADES SEPARADO DE DEPÓSITO DE LOS DIFERENTES SERVICIOS Y SEPARADO EL MANEJO DE DIFERENTES FLUIDO DE CORTE.

THIS EQUIPMENT IS INTENDED FOR USE WITH STANDARD MACHINE-TOOL COOLANT (WATER-BASE AND CUTTING OILS) ONLY. IT SHOULD NOT BE USED WITH FLAMMABLE FLUIDS (I.E. FUELS, PAINT, SOLVENTS, ETC.), CORROSIVE, TOXIC OR REACTIVE MATERIALS. DO NOT USE IN EXTRA-HIGH TEMPERATURE OR SPARK-HAZARD ENVIRONMENTS (I.E. OVENS WELDING AREAS, ETC.). CLEAN TANK THOROUGHLY ON A FREQUENT BASIS, ESPECIALLY WHEN PUMPING DIFFERENT TYPES OF COOLANT AND SOLIDS OF DIFFERENT MATERIAL. WE RECOMMEND SEPARATE TANK UNITS FOR DIFFERENT SERVICES AND SEGREGATED HANDLING OF DIFFERENT COOLANTS.

- NO FLAMMABLE FLUIDS/MATERIALS WITH A FLASH POINT UNDER 200°F.
- NO TOXIC MATERIALS.
- NO CORROSIVE MATERIALS WITH PH LESS THAN 5 OR GREATER THAN 12.
- NO REACTIVE MATERIALS.

1.2 – PRECAUTIONS

- READ THROUGH THE "OPERATIONS MANUAL" COMPLETELY BEFORE ATTEMPTING TO OPERATE THE MACHINE.

- RELIEF VALVES ARE SET BEFORE SHIPMENT AND SHOULD NOT BE CHANGED AS THE USE OF EXCESSIVE PRESSURE COULD CAUSE SERIOUS INJURY OR DAMAGE.

- DO NOT ATTEMPT TO REMOVE SUMP CLEANER BEFORE RELIEVING PRESSURE IN THE DRUM TANK.

- WEAR SAFETY GOGGLES TO PROTECT EYES FROM SPLASHING LIQUIDS.

- KEEP HANDS AND FINGERS CLEAR OF DRUM TANK OPENING WHEN REMOVING DRUM TOP.

SECTION 2 – THE SUMP CLEANER

2.1 – UNIT IDENTIFICATION

WHEN ORDERING PARTS OR ASKING QUESTIONS REGARDING YOUR SUMP SHARK, IT IS IMPORTANT TO HAVE THE MODEL AND SERIAL NUMBER OF THE UNIT. THE MODEL AND SERIAL NUMBER CAN BE FOUND ON THE SUMP CLEANER'S NAMEPLATE LOCATED ON THE FRONT PANEL.

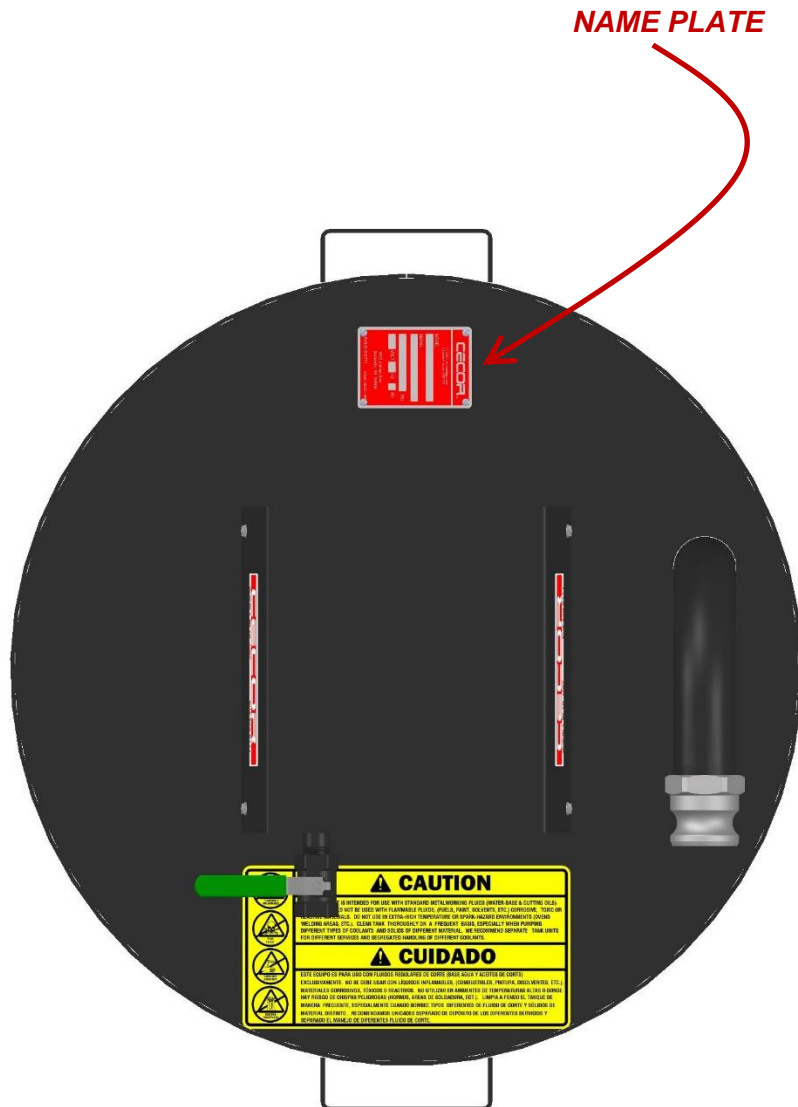

2.2 – MODEL & SERIAL NUMBER

THE MODEL NUMBER IDENTIFIES YOUR SUMP CLEANER AND INDICATES STANDARD FEATURES ON YOUR MACHINE. THE SERIAL NUMBER IDENTIFIES YOUR SPECIFIC SUMP CLEANER AND WILL HELP IDENTIFY ANY SPECIAL FEATURES THAT MAY BE UNIQUE TO YOUR SUMP CLEANER. THE SERIAL NUMBER IS LOCATED ON THE NAMEPLATE.

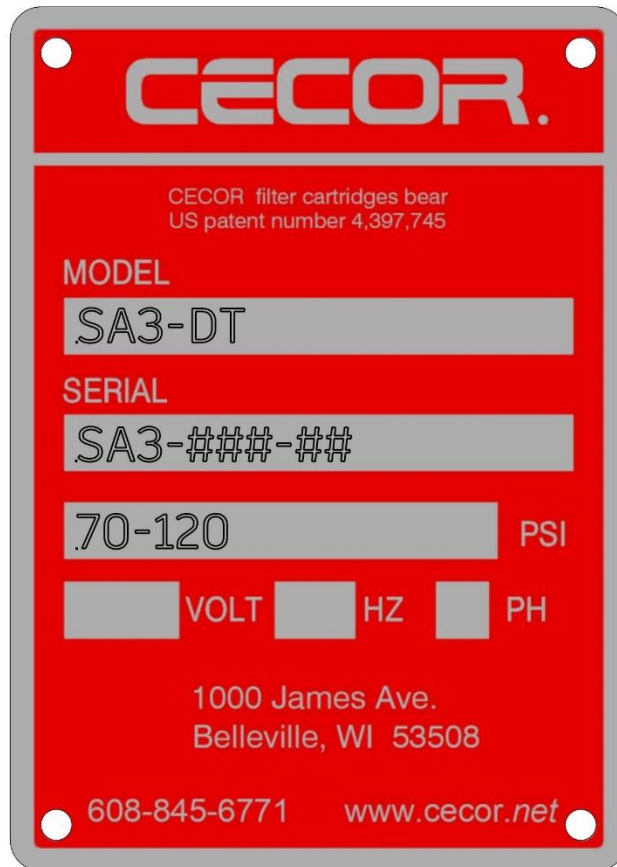

2.3 – DRUM TOP FEATURES

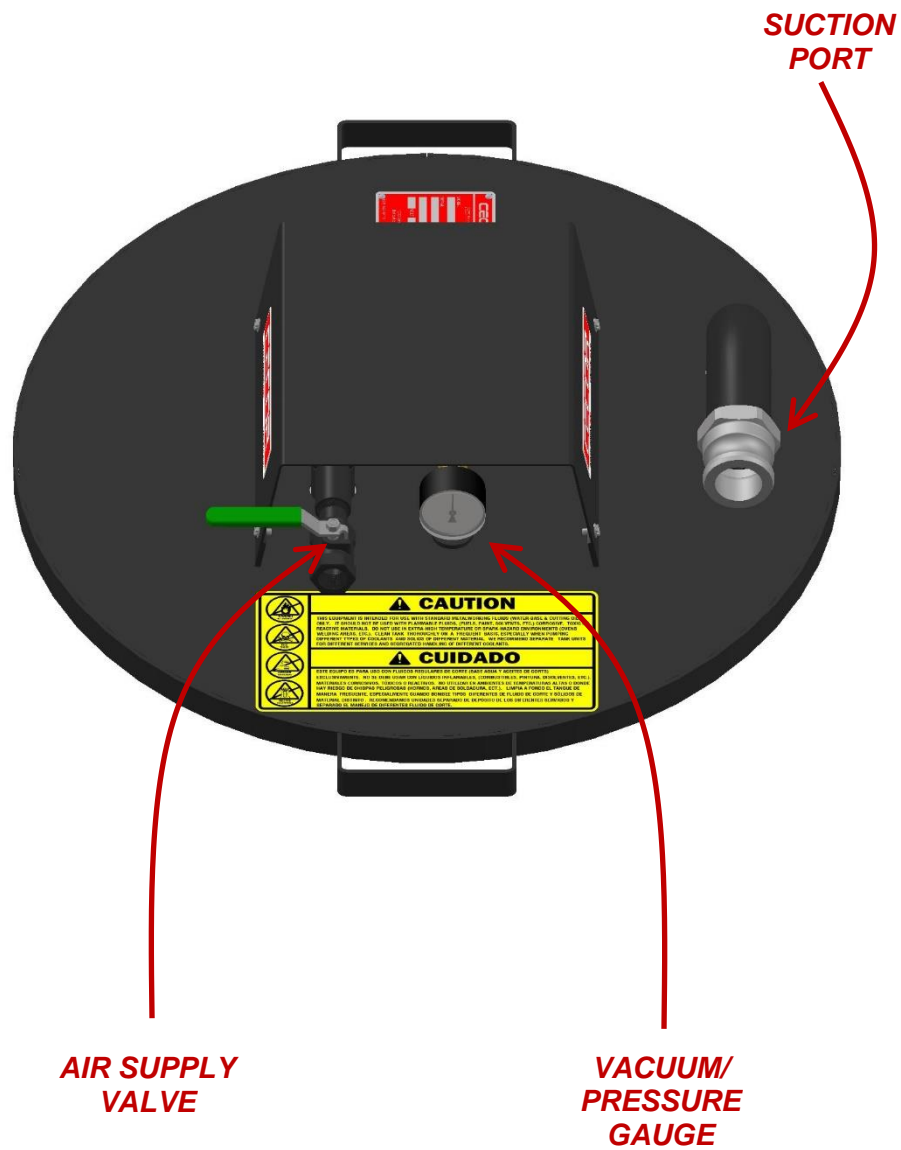

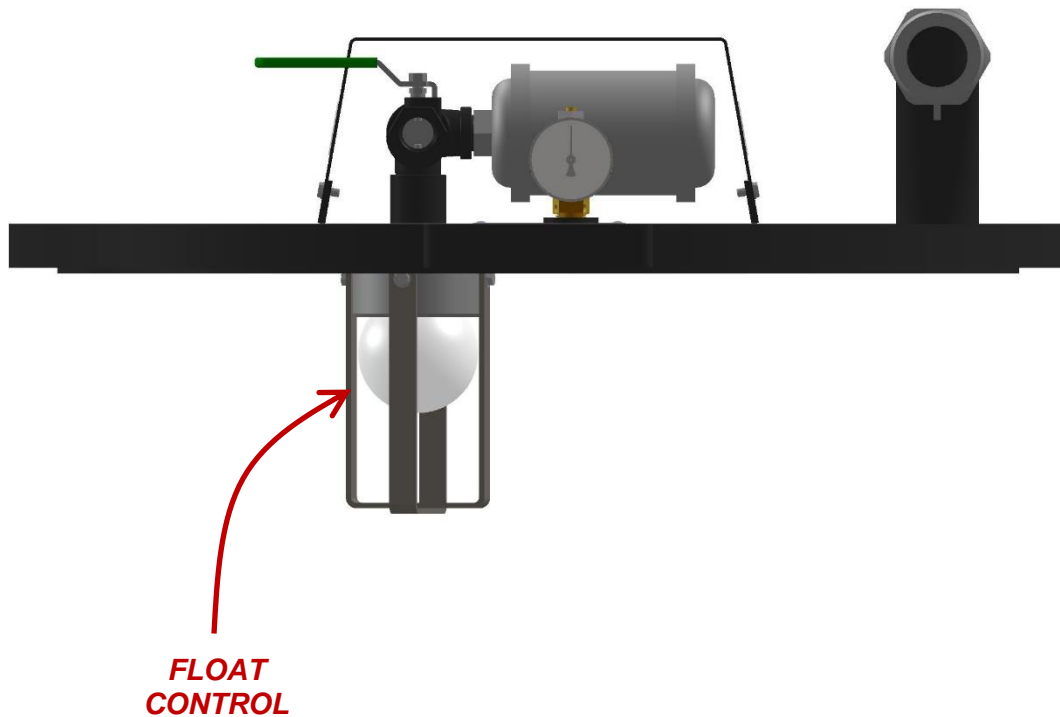

THE VACUUM RELIEF VALVE IS SET FROM THE FACTORY TO 12 inHg. IF THE VACUUM IS TOO GREAT FOR THE 55-GALLON DRUMS USED, THE VACUUM RELIEF MAY BE ADJUSTED DOWN TO DECREASE THE VACUUM. IF THE SUMP CLEANER IS USED IN CONJUNCTION WITH CECOR'S TX-55PL, VACUUMS UP TO 26 inHg MAY BE REACHED.

SECTION 3 – INSTALLATION

3.1 – ASSEMBLE FLOAT CONTROL

FOR SHIPPING PURPOSE, SOME MODELS MAY REQUIRE THE INSTALL OF THE DISCHARGE VALVE AND QUICK DISCONNECT ADAPTER. USE PIPE SEALANT ON ALL JOINTS AND TIGHTEN SECURELY.

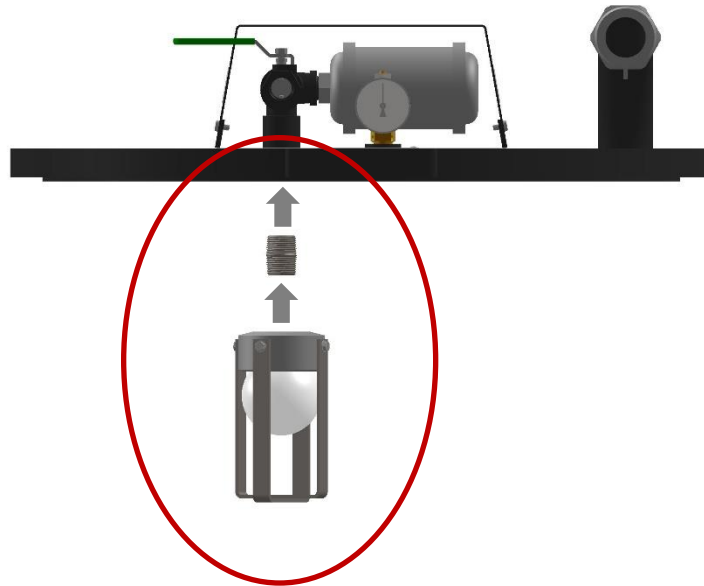

3.2 – LOOSE ITEMS

SOME ITEMS MAY BE PACKAGED IN A BOX LOCATED ON THE SHIPPING PALLET. PACKAGES WITH FILTER BASKET OR FILTER ASSEMBLIES WILL HAVE FILTERS INSTALLED. PLEASE REVIEW YOUR PACKING LIST TO SEE WHAT ADDITIONAL ITEMS YOU WILL BE RECEIVING.

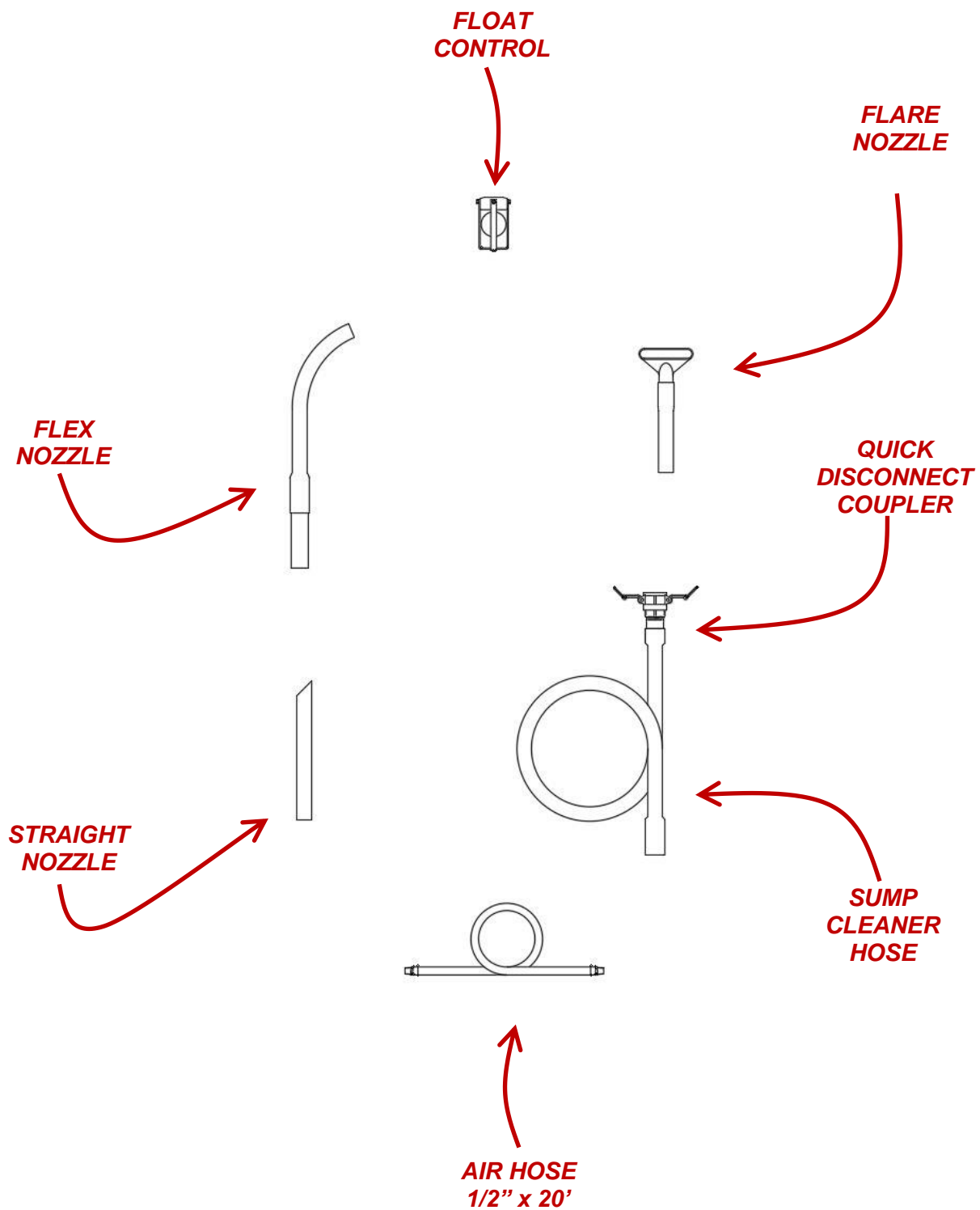

3.3 – AIR SUPPLY CONNECTION

YOU ARE REQUIRED TO SUPPLY AIR CONNECTIONS THAT FIT YOUR AIR SYSTEM. THE SHARKS AIR-LINE TERMINATES IN ½” NPT PIPE THREAD. THE SHARK REQUIRES A MINIMUM 3/8” DISCONNECT; (½” FOR OPTIMAL PERFORMANCE). ¼” BLOW-OFF CONNECTIONS ARE TOO LIMITING ON THE AIR SUPPLY REDUCING PERFORMANCE.



SECTION 4 – OPERATION

4.1 – SETTING UP DRUM TOP

1. SCREW FLOAT CONTROL ONTO PIPE PROTRUDING THROUGH LID UNDERSIDE. (SEE 3.1 – ASSEMBLY FLOAT CONTROL)
2. PLACE UNIT ON AN OPTIONAL CECOR TX-55PL DRUM TANK OR AN EMPTY OPEN-ENDED 55 GALLON DRUM.



3. ATTACH THE SUMP CLEANER HOSE TO THE SUCTION PORT, AND INSERT SUCTION TOOL INTO HOSE END.

- CONNECT AIR HOSE TO SHOP SUPPLY. SHOP AIR SUPPLY MUST BE BETWEEN 75-120 PSI FOR BEST RESULTS.

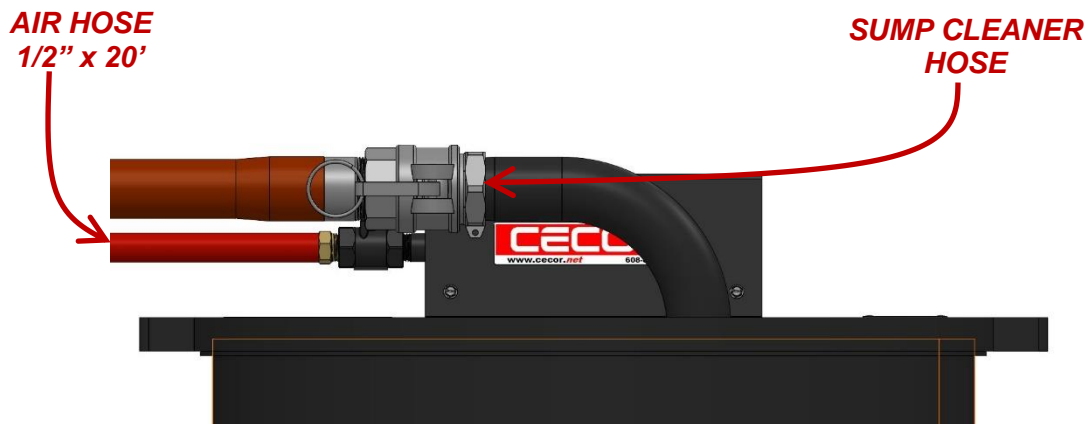

- OPEN AIR SUPPLY VALVE.

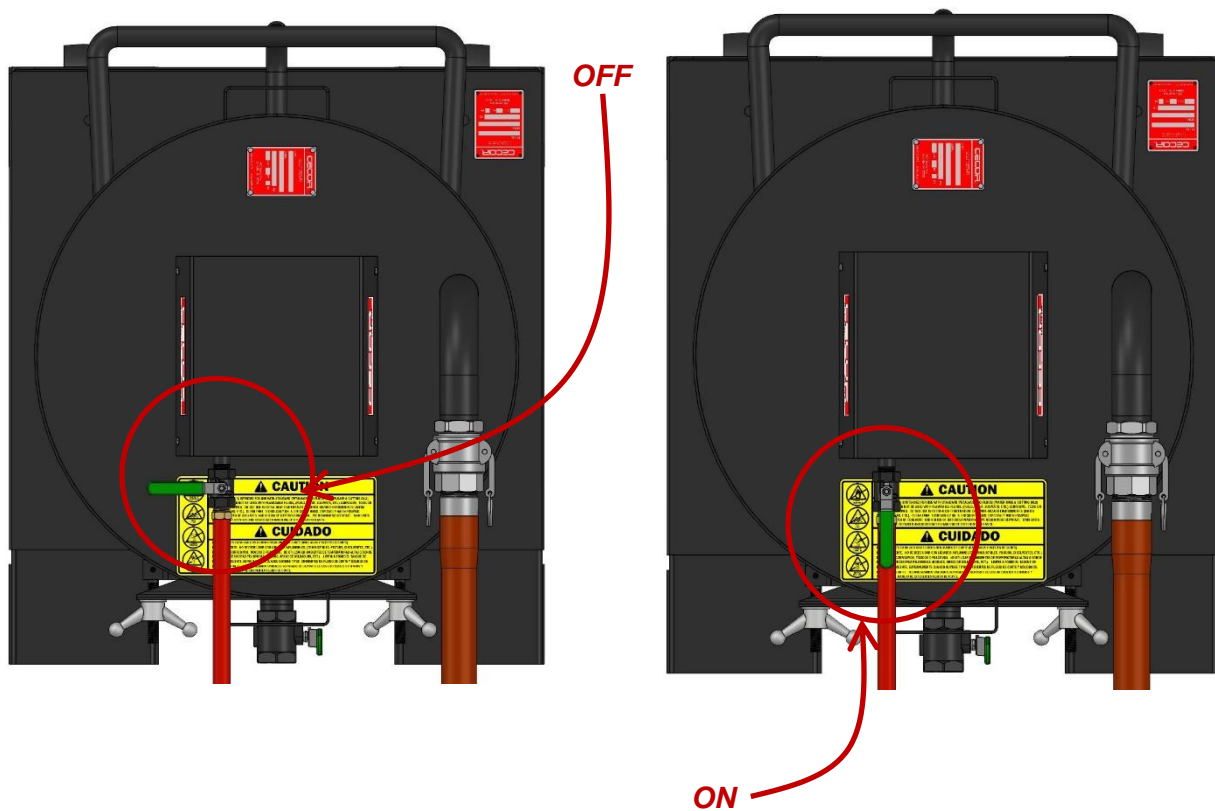

- SUMP CLEANER IS READY FOR USE.

SECTION 5 – MAINTENANCE

TO GET THE HIGHEST PERFORMANCE FROM YOUR SUMP CLEANER, IT IS IMPORTANT TO KEEP IT WELL MAINTAINED. BELOW IS A MAINTENANCE GUIDE THAT WILL KEEP YOUR SUMP CLEANER IN TOP-NOTCH, DEPENDABLE CONDITION. ANY WORN OR DAMAGED PART SHOULD BE REPLACED IMMEDIATELY. CECOR STOCKS SUMP CLEANER PARTS AND MOST CAN BE SHIPPED THE SAME OR THE NEXT DAY. CALL 1-800-356-9042 TO ORDER PARTS.

5.1 – DAILY MAINTENANCE

1. CHECK THE VACUUM GAUGE TO SEE THAT IT IS OPERATING AND READING CORRECTLY. TANK PRESSURE SHOULD NOT EXCEED PRESSURES OF 13 inHg.
2. DEFECTIVE RELIEF VALVE SHOULD BE REPLACED IMMEDIATELY.
3. CHECK FOR GASKET LEAKS AND ANY CHASSIS DAMAGE.

5.2 – WEEKLY MAINTENANCE

1. CLEAN AND INSPECT TANK FLOAT CONTROL. SEE THAT THE FLOAT BALL SEALS AGAINST THE GASKET. THE FLOAT CONTROL ASSEMBLY CAN BE ASSESSED THROUGH THE POT OPENING IN THE SUMP CLEANER.

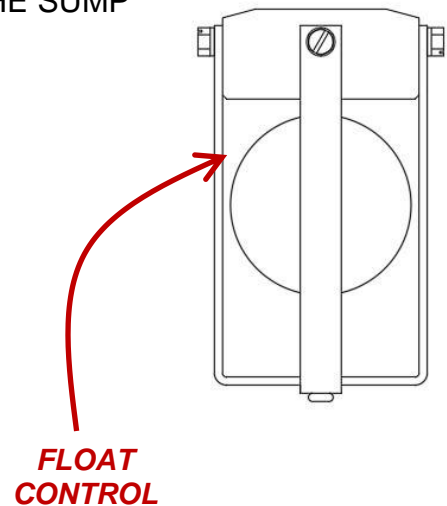

5.3 – MONTHLY MAINTENANCE

1. INSPECT SUMP CLEANER HOSE.

SECTION 6 – TROUBLESHOOTING

PROBLEM	POSSIBLE CAUSE:	SOLUTION:
WILL NOT START	AIR SUPPLY.	MAKE SURE THE UNIT IS CONNECTED TO AN ADEQUATE AIR SUPPLY.
	HOSE RESRICTIONS.	CHECK AIR LINES FOR KINKS OR OTHER RESTRICTIONS.
	BLOCKAGE OF AIR FLOW.	CHECK FOR DEBRIS THAT MAY HAVE COME THROUGH THE AIR LINE.
LOSS OF SUCTION	VACUUM GAUGE READS "0" VACUUM.	TANK IS FULL; EMPTY TANK.
		AIR LEAKAGE; CHECK GASKETS AND LOOSE CONNECTIONS.
	VACUUM GAUGE READS LOW SUCTION.	CHECK FOR CORRECT SIZE AIR CONNECTIONS.
		1/2" AIR LINES SHOULD NOT EXCEED 40'.
		CHECK FOR AIR FLOW OUT OF THE MUFFLER.

SECTION 7 – REPAIR PARTS LIST

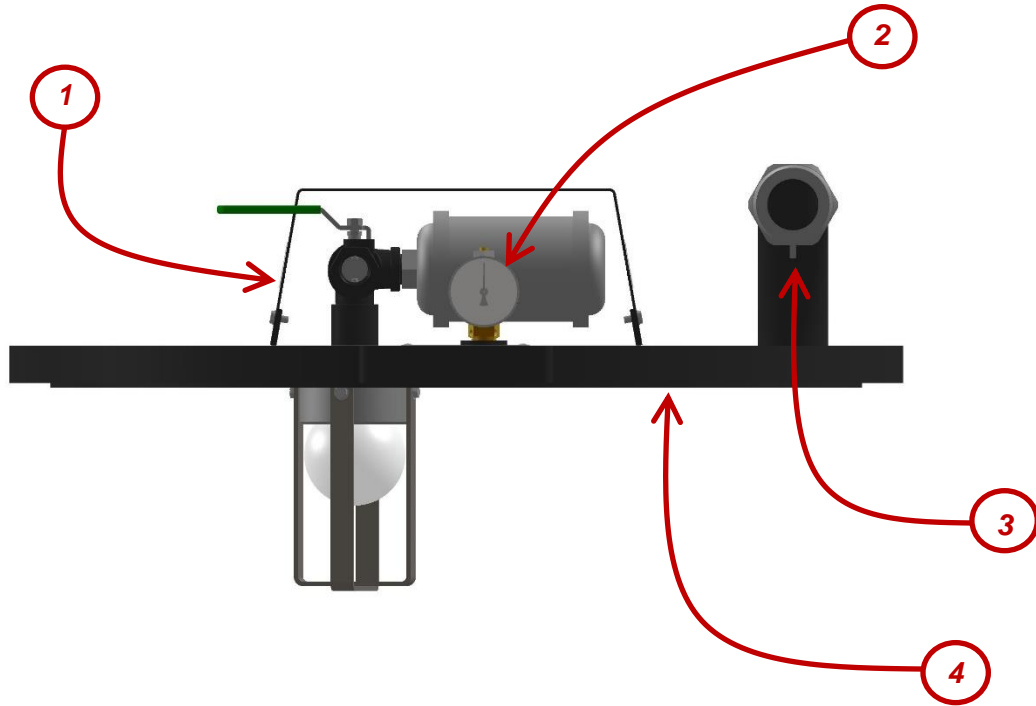

Ref	Part No.	Description
1	ADT0.0027	HOOD
2	PPLM.0000.0013.0000	VAVUUM GAUGE
3	PPLM.0000.0036.0000	DISCONNECT ADAPTER
4	ADT0.0001	DRUM GASKET

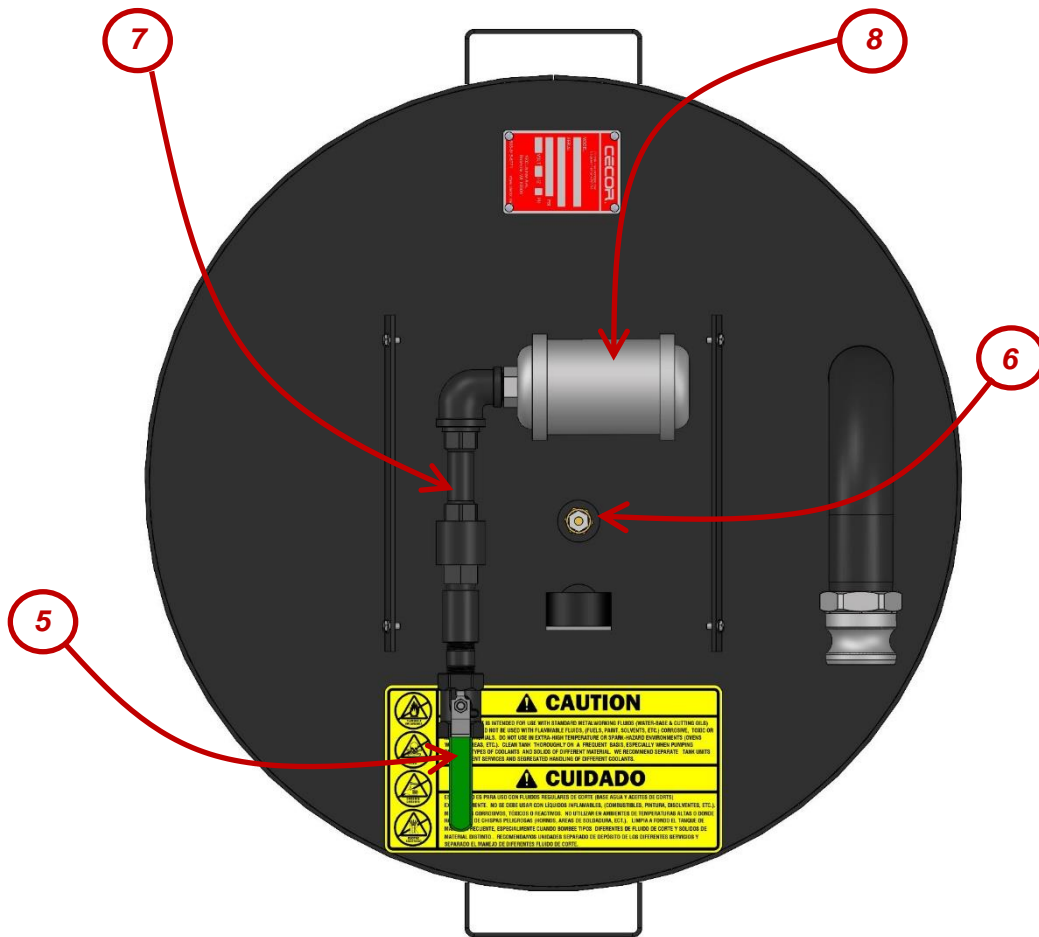

Ref	Part No.	Description
5	PVAL.BTFY.0001.0000	AIR SUPPLY VALVE
6	PVAL.RELF.0001.0000	VACUUM RELIEF VALVE
7	PPLM.0000.0011.0000	AIR EXHAUSTER
8	PPLM.0000.0034.0000	MUFFLER

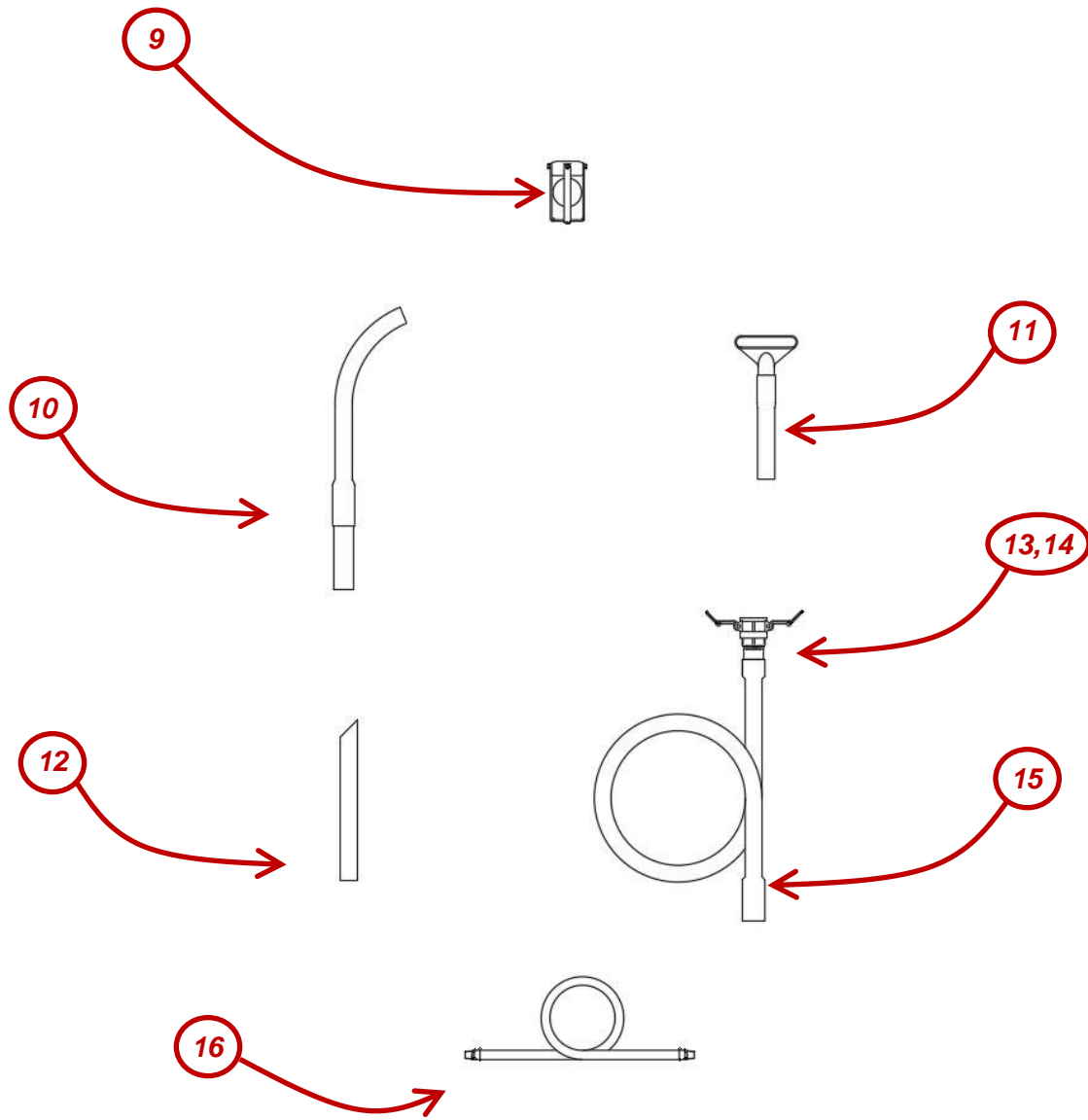

Ref	Part No.	Description
9	ASC0.0004	FLOAT CONTROL
10	ASC0.0033	FLEX NOZZLE
11	ASC0.0032	FLARED NOZZLE
12	ADT0.0019	STRAIGHT NOZZLE
13	PPLM.0000.0035.0000	QUICK DISCONNECT COUPLER
14	PGAS.0000.0006.0150	COUPLER GASKET
15	ASC0.0027	1-1/2" SUMP CLEANER HOSE
16	PHOS.EPDM.0001.0000	AIR HOSE 1/2" x 20'

SECTION 8 – ACCESSORIES

TX-55PL



CECOR'S HEAVY DUTY 55-GALLON DRUM TANK, MADE OF HEAVY GAUGE STEEL, IS STRONGER THAN A STANDARD 55-GALLON DRUM. THE TANK IS MOUNTED ON FOUR CASTERS FOR EASY ROLLING AND MANEUVERABILITY. FORK POCKETS BUILT INTO THE BASE PROVIDE EASY HANDLING BY FORK TRUCK. THE TANK FEATURES AN 8" X 10" CLEANOUT DOOR FOR REMOVING SETTLED SOLIDS. VALVE IN DOOR PERMITS FLUID TO DRAIN OUT, LEAVING THE SOLIDS.

SECTION 9 – WARRANTY

WARRANTY STATEMENT

PLEASE PRINT OUR WARRANTY AT [HTTPS://CECOR.NET/CECOR-WARRANTY/](https://cecor.net/cecor-warranty/)

SECTION 10 – RECORD MODEL & SERIAL NUMBER

WHEN YOU RECEIVE YOUR CECOR SUMP SHARK, RECORD THE MODEL NUMBER, SERIAL NUMBER AND DATE DELIVERED FOR YOUR RECORDS.

<p>MODEL #: _____</p> <p>SERIAL #: _____</p> <p>DELIVERED: _____ / _____ / _____</p>

CECOR®

