



## **OPERATION MANUAL & PARTS LIST**

**MODEL:**

**CA5 HORIZONTAL TANK SERIES**

**100/100, 150/150, 200/200, 250/250  
GALLON**

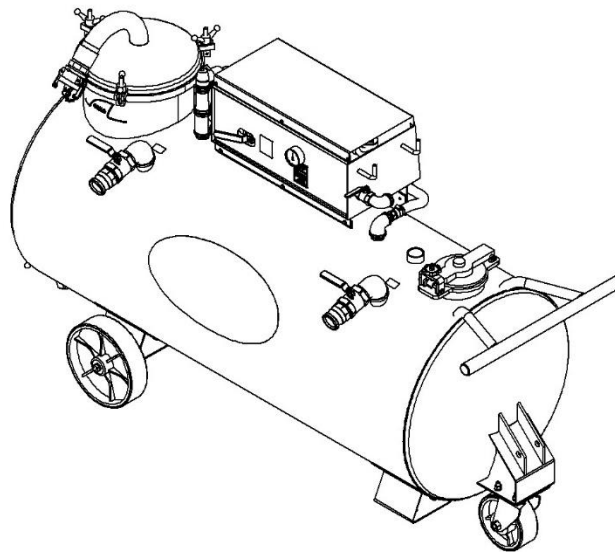

# TABLE OF CONTENTS

SECTION 1 – SAFETY INFORMATION .....	4
1.1 – CAUTION .....	4
1.2 – PRECAUTIONS .....	5
SECTION 2 – THE SUMP CLEANER .....	6
2.1 – UNIT IDENTIFICATION .....	6
2.2 – SUMP CLEANER FEATURES.....	7
SECTION 3 – INSTALLATION .....	8
3.1 – ASSEMBLE DISCHARGE CONNECTION.....	8
3.2 – LOOSE ITEMS.....	8
3.3 – INITIAL STARTUP .....	10
SECTION 4 – OPERATION .....	14
4.1 – CLEANING A SUMP.....	14
4.2 – DISCHARGING FLUID FROM THE DIRTY TANK.....	15
4.3 – FILLING CLEAN TANK WITH COOLANT .....	16
4.4 – DISCHARGING FLUID FROM THE SUMP CLEANER CLEAN TANK .....	17
4.5 – FILTER.....	18
4.5.1 – F10 FILTER .....	18
4.5.2 – F23 FILTER .....	20
4.4 – CLEANING THE SUMP CLEANER .....	24
SECTION 5 – MAINTENANCE .....	26
5.1 – DAILY MAINTENANCE.....	26
5.2 – WEEKLY MAINTENANCE .....	26
5.3 – MONTHLY MAINTENANCE .....	27
SECTION 6 – TROUBLESHOOTING .....	28
SECTION 7 – REPAIR PARTS LIST .....	29
7.1 – SUMP CLEANER .....	29
7.1.1 WHEELS - “PTL” PUSH TOW LIFT TRANSPORT 100/100 GAL .....	29
7.1.2 WHEEL “TW” TOW TRANSPORT 150/150 & 200/200 GAL .....	30
7.1.3 WHEEL “TW” TOW TRANSPORT 250/250 GAL.....	31
7.2 – TANK.....	32
7.3 – PUMP ASSEMBLY.....	35
7.4 – DISPENSER HOSE (STANDARD).....	36

7.5 – SUMP CLEANER HOSE 1-1/2" x 16' (STANDARD) ..... 37  
7.6 – SUMP CLEANER HOSE 2" x 16' (OPTIONAL) ..... 38  
7.7 – F10 FILTER (STANDARD) ..... 39  
7.8 – F23 FILTER (OPTIONAL) ..... 40  
SECTION 8 – WARRANTY ..... 41  
SECTION 9 – RECORD MODEL & SERIAL NUMBER ..... 42

## SECTION 1 – SAFETY INFORMATION

### 1.1 – CAUTION

 FLAMMABLE INFLAMMABLE  TOXIC TÓXICO  CORROSIVE CORROSIVO  REACTIVE REACTIVIDAD	 <b>CAUTION</b>
	THIS EQUIPMENT IS INTENDED FOR USE WITH STANDARD METALWORKING FLUIDS (WATER-BASE & CUTTING OILS) ONLY. IT SHOULD NOT BE USED WITH FLAMMABLE FLUIDS, (FUELS, PAINT, SOLVENTS, ETC.) CORROSIVE, TOXIC OR REACTIVE MATERIALS. DO NOT USE IN EXTRA-HIGH TEMPERATURE OR SPARK-HAZARD ENVIRONMENTS (OVENS WELDING AREAS, ETC.). CLEAN TANK THOROUGHLY ON A FREQUENT BASIS, ESPECIALLY WHEN PUMPING DIFFERENT TYPES OF COOLANTS AND SOLIDS OF DIFFERENT MATERIAL. WE RECOMMEND SEPARATE TANK UNITS FOR DIFFERENT SERVICES AND SEGREGATED HANDLING OF DIFFERENT COOLANTS.
	 <b>CUIDADO</b>
	ESTE EQUIPO ES PARA USO CON FLUIDOS REGULARES DE CORTE (BASE AGUA Y ACEITES DE CORTS) EXCLUSIVAMENTE. NO SE DEBE USAR CON LÍQUIDOS INFLAMABLES, (COMBUSTIBLES, PINTURA, DISOLVENTES, ETC.). MATERIALES CORROSIVOS, TÓXICOS O REACTIVOS. NO UTILIZAR EN AMBIENTES DE TEMPERATURAS ALTAS O DONDE HAY RIESGO DE CHISPAS PELIGROSAS (HORNO, AREAS DE SOLDADURA, ECT.). LIMPIA A FONDO EL TANQUE DE MANERA FRECUENTE, ESPECIALMENTE CUANDO BOMBEE TIPOS DIFERENTES DE FLUIDO DE CORTE Y SÓLIDOS DE MATERIAL DISTINTO . RECOMENDAMOS UNIDADES SEPARADO DE DEPÓSITO DE LOS DIFERENTES SERVICIOS Y SEPARADO EL MANEJO DE DIFERENTES FLUIDO DE CORTE.

THIS EQUIPMENT IS INTENDED FOR USE WITH STANDARD MACHINE-TOOL COOLANT (WATER-BASE AND CUTTING OILS) ONLY. IT SHOULD NOT BE USED WITH FLAMMABLE FLUIDS (I.E. FUELS, PAINT, SOLVENTS, ETC.), CORROSIVE, TOXIC OR REACTIVE MATERIALS. DO NOT USE IN EXTRA-HIGH TEMPERATURE OR SPARK-HAZARD ENVIRONMENTS (I.E. OVENS WELDING AREAS, ETC.). CLEAN TANK THOROUGHLY ON A FREQUENT BASIS, ESPECIALLY WHEN PUMPING DIFFERENT TYPES OF COOLANT AND SOLIDS OF DIFFERENT MATERIAL. WE RECOMMEND SEPARATE TANK UNITS FOR DIFFERENT SERVICES AND SEGREGATED HANDLING OF DIFFERENT COOLANTS.

- NO FLAMMABLE FLUIDS/MATERIALS WITH A FLASH POINT UNDER 200°F.
- NO TOXIC MATERIALS.
- NO CORROSIVE MATERIALS WITH PH LESS THAN 5 OR GREATER THAN 12.
- NO REACTIVE MATERIALS.

## 1.2 – PRECAUTIONS

- READ THROUGH THE "OPERATIONS MANUAL" COMPLETELY BEFORE ATTEMPTING TO OPERATE THE MACHINE.
  
- CLEANOUT, POT LID, INLET CAP AND HOSES MUST BE IN PLACE AND TIGHTLY SECURED BEFORE OPERATION IN THE DISCHARGE MODE.
  
- TANK DISCHARGE PRESSURE MUST NOT EXCEED 10 PSI. REGULATOR AND RELIEF VALVES ARE SET BEFORE SHIPMENT AND SHOULD NOT BE CHANGED AS THE USE OF EXCESSIVE PRESSURE COULD CAUSE SERIOUS INJURY OR DAMAGE. OPERATING DISCHARGE PRESSURE IS 6 PSI.
  
- DO NOT ATTEMPT TO OPEN POT LID, CLEANOUT OR BLEED-OFF CAP BEFORE RELIEVING PRESSURE IN THE TANK.
  
- BLOCK WHEELS OF THE MACHINE TO PREVENT UNINTENTIONAL MOVEMENT.
  
- WEAR SAFETY GOGGLES TO PROTECT EYES FROM SPLASHING LIQUIDS.
  
- KEEP HANDS AND FINGERS CLEAR OF POT OPENING WHEN REMOVING OR REPLACING FILTER BASKET OR FILTER ASSEMBLY.

## SECTION 2 – THE SUMP CLEANER

### 2.1 – UNIT IDENTIFICATION

WHEN ORDERING PARTS OR ASKING QUESTIONS REGARDING YOUR SUMP SHARK, IT IS IMPORTANT TO HAVE THE MODEL AND SERIAL NUMBER OF THE UNIT. THE MODEL AND SERIAL NUMBER CAN BE FOUND ON THE SHARK'S NAMEPLATE LOCATED ON THE FRONT PANEL OF THE PUMP ASSEMBLY.

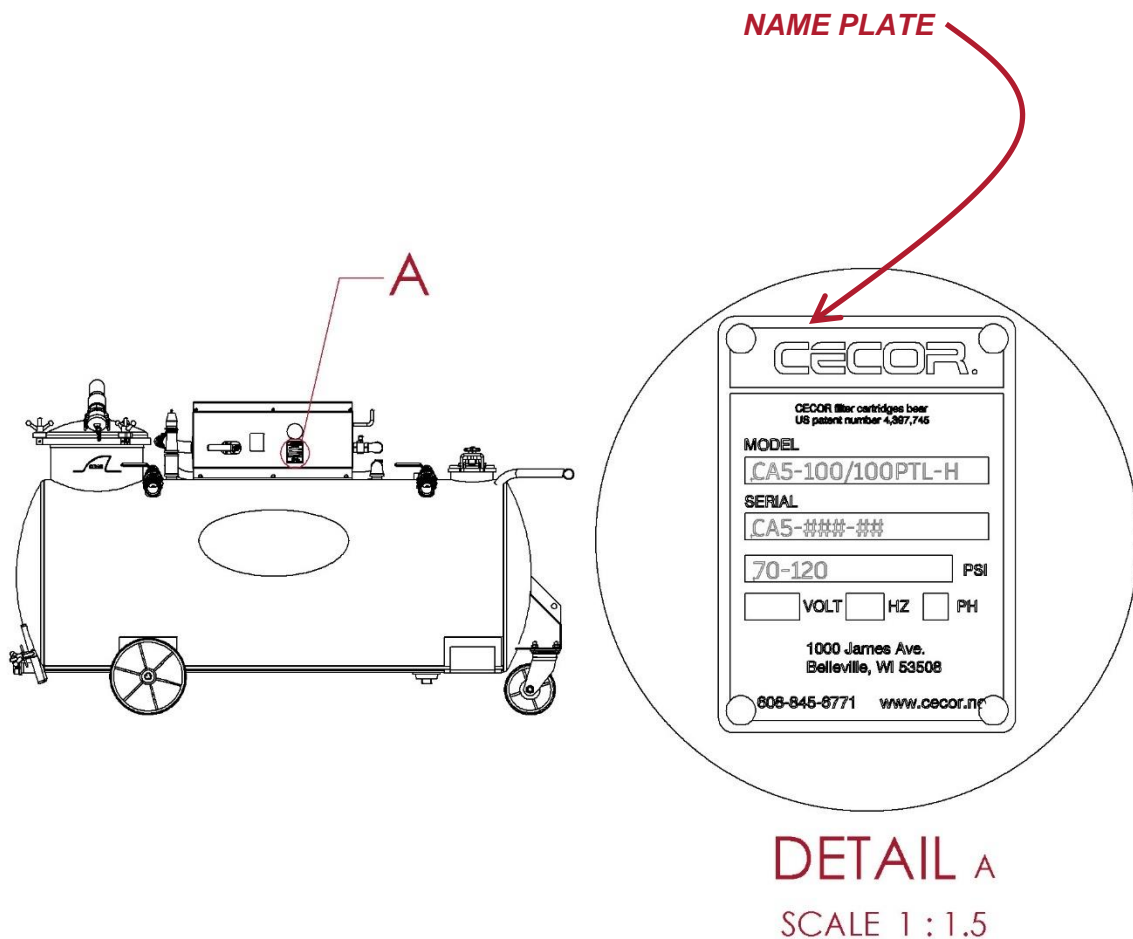

## 2.2 – SUMP CLEANER FEATURES

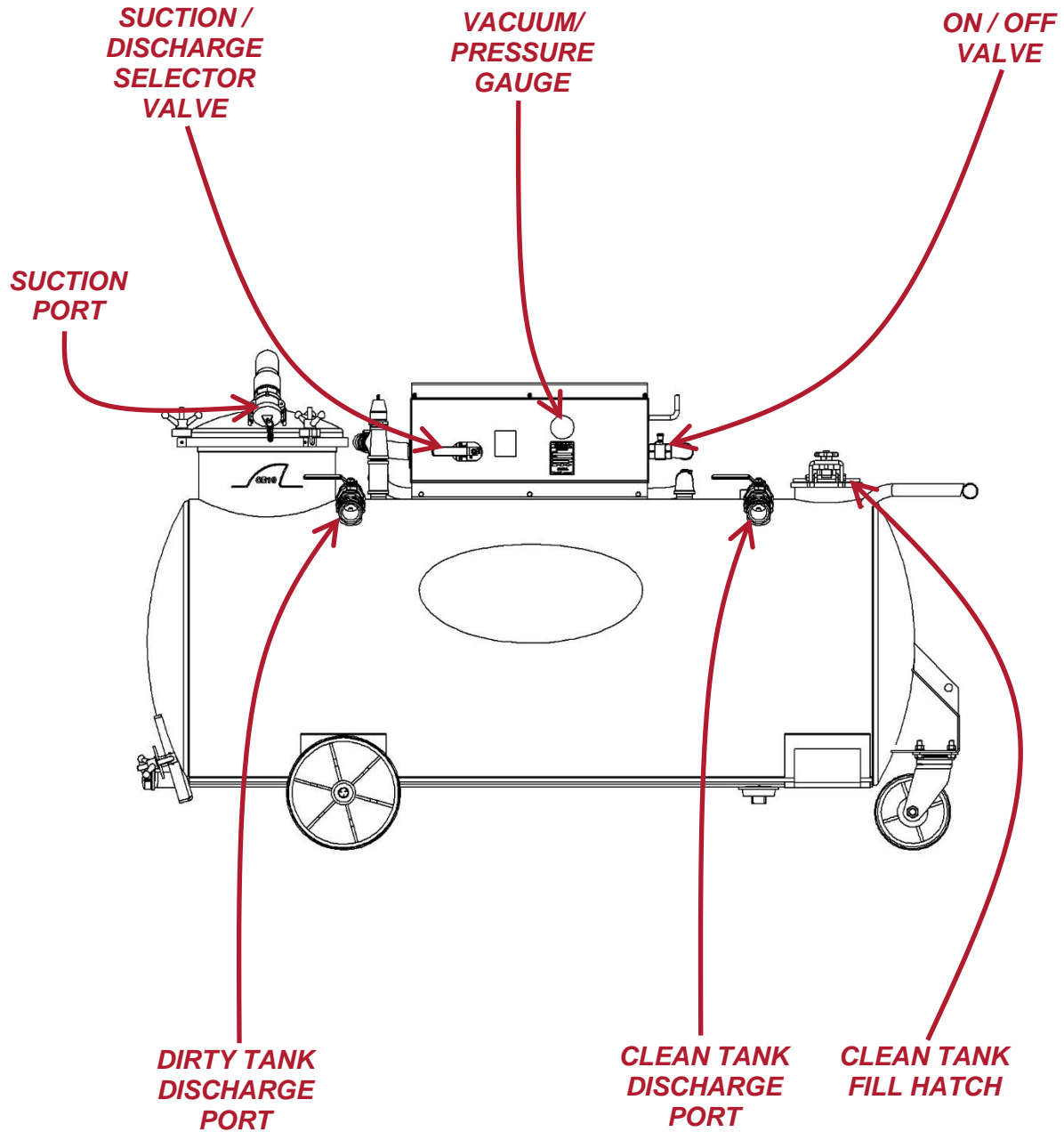

## SECTION 3 – INSTALLATION

### 3.1 – ASSEMBLE DISCHARGE CONNECTION

FOR SHIPPING PURPOSE, SOME MODELS MAY REQUIRE THE INSTALL OF THE DISCHARGE VALVE AND QUICK DISCONNECT ADAPTER. USE PIPE SEALANT ON ALL JOINTS AND TIGHTEN SECURELY.

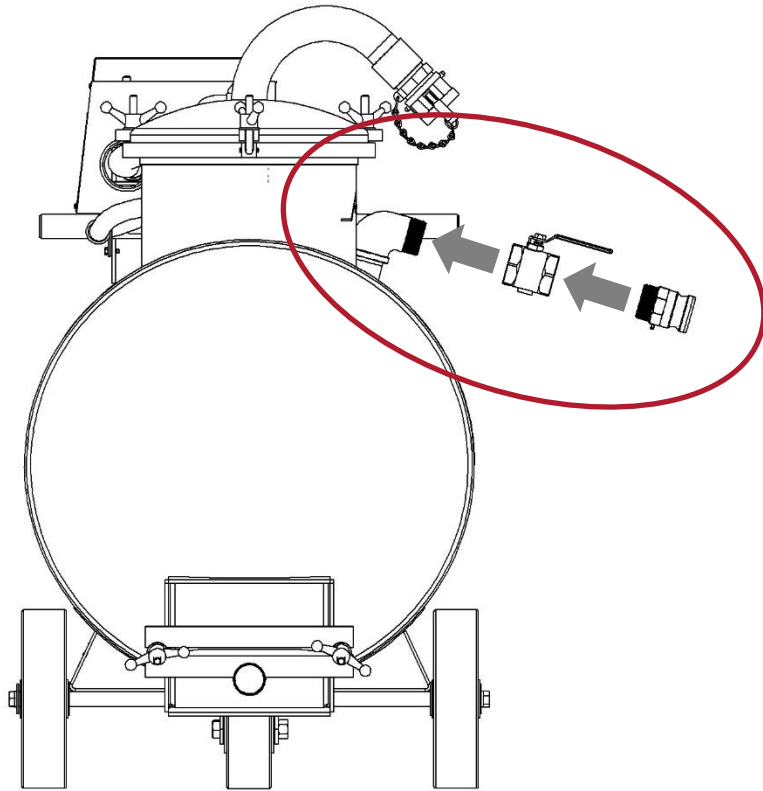

### 3.2 – LOOSE ITEMS

SOME ITEMS MAY BE PACKAGED IN A BOX LOCATED ON THE SHIPPING PALLET. PACKAGES WITH FILTER BASKET OR FILTER ASSEMBLIES WILL HAVE FILTERS INSTALLED. PLEASE REVIEW YOUR PACKING LIST TO SEE WHAT ADDITIONAL ITEMS YOU WILL BE RECEIVING.



**FINE  
STRAINER BAG**



**COARSE  
STRAINER BAG**



**POLY  
STRAINER BAG**



**FLARE  
NOZZLE**

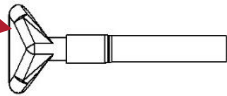

**STRAIGHT  
NOZZLE**



**FLEX  
NOZZLE**



**AIR HOSE  
1/2" x 20'**

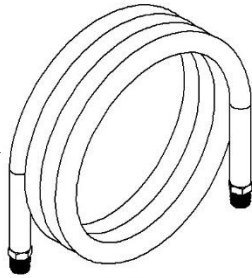

**F10 BASKET  
ASSEMBLY**

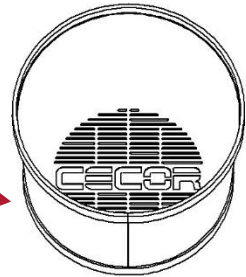

**SUMP  
CLEANER  
HOSE**

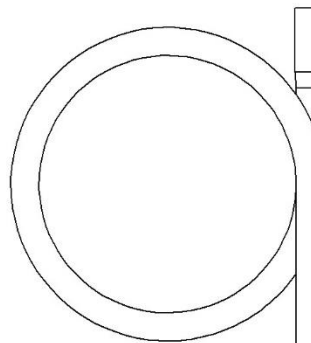

**QUICK  
DISCONNECT  
COUPLER**



**DISPENSER  
NOZZLE**

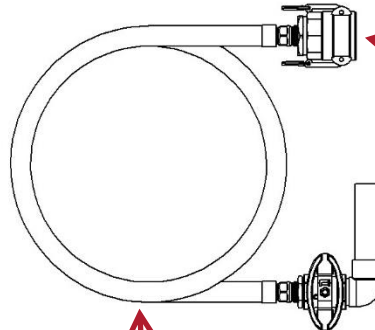

**DISPENSER  
HOSE**



### 3.3 – INITIAL STARTUP

1. CLOSE AND SECURE ALL TANK SUCTION AND DISCHARGE PORTS.

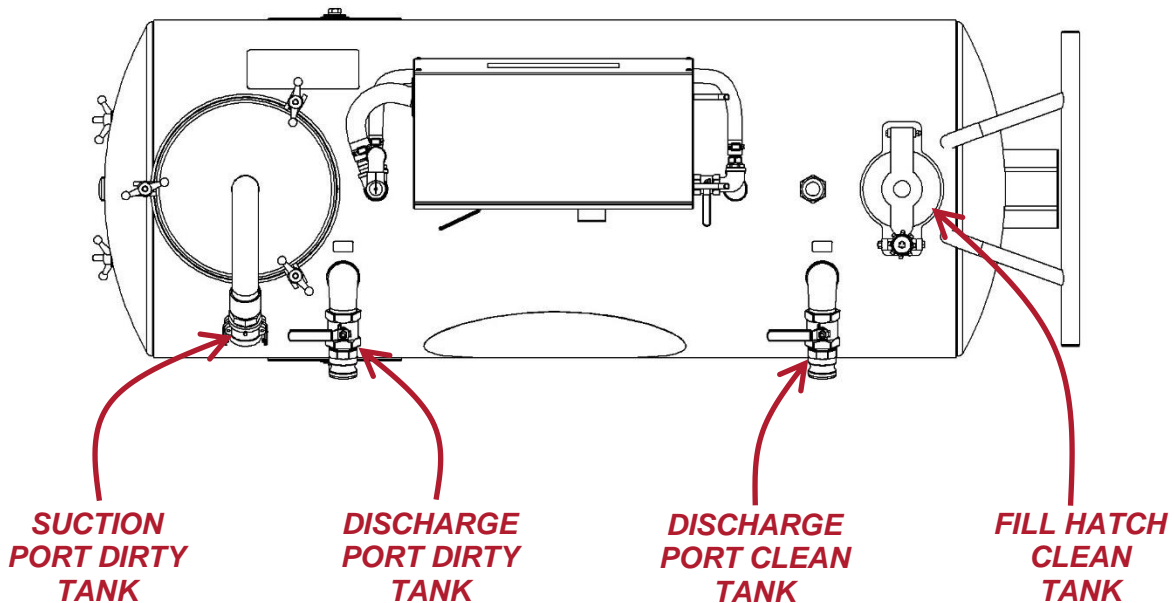

2. YOU ARE REQUIRED TO SUPPLY AIR CONNECTIONS THAT FIT YOUR AIR SYSTEM. THE SHARKS AIR-LINE TERMINATES IN 1/2" NPT PIPE THREAD. THE SHARK REQUIRES A MINIMUM 3/8" DISCONNECT; (1/2" FOR OPTIMAL PERFORMANCE). 1/4" BLOW-OFF CONNECTIONS ARE TOO LIMITING ON THE AIR SUPPLY REDUCING PERFORMANCE.

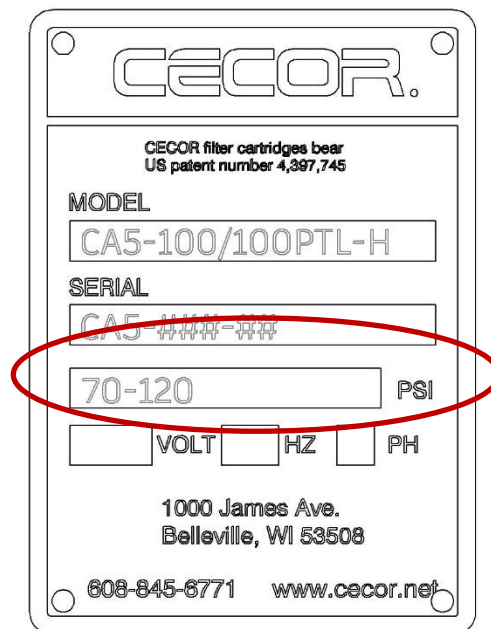

3. **RUN THE UNIT IN “SUCTION” MODE.** WITH AIR SUPPLY VALVE IN THE OFF, POSITION CONNECT THE AIR-LINE TO YOUR SYSTEM. TURN SELECTOR VALVE TO SUCTION.

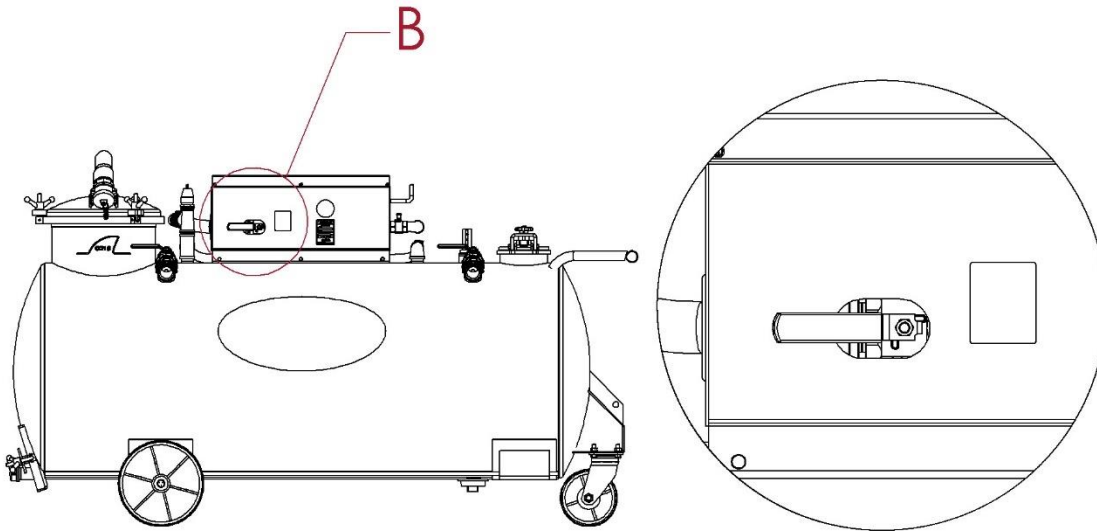

**DETAIL B**

SCALE 1 : 6

4. OPEN THE AIR SUPPLY VALVE. THE VACUUM READING SHOULD INCREASE TO 20-26” HG.

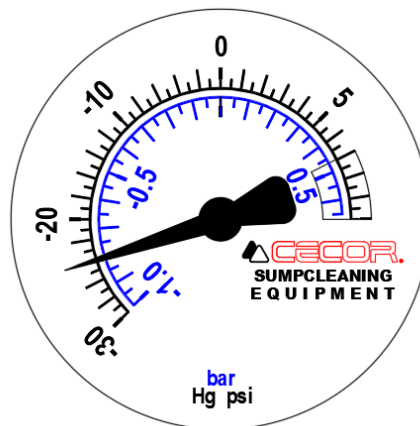

5. CLOSE AIR SUPPLY VALVE.
6. **RUN THE UNIT IN “DISCHARGE” MODE.** CHANGE THE SELECTOR VALVE TO DISCHARGE.

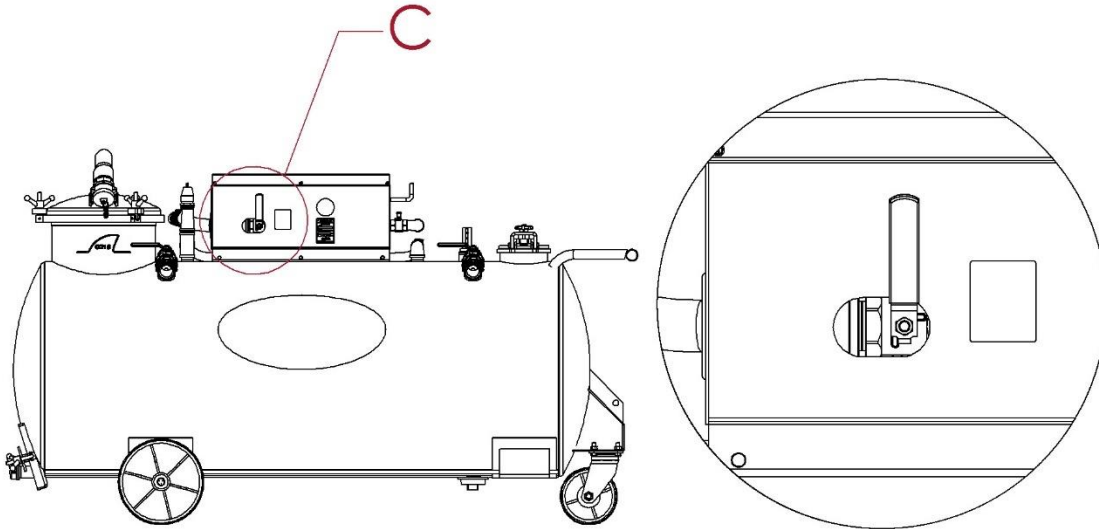

**DETAIL C**

SCALE 1 : 6

7. OPEN THE AIR SUPPLY VALVE. THE PRESSURE READING SHOULD INCREASE TO 5-7 PSI.

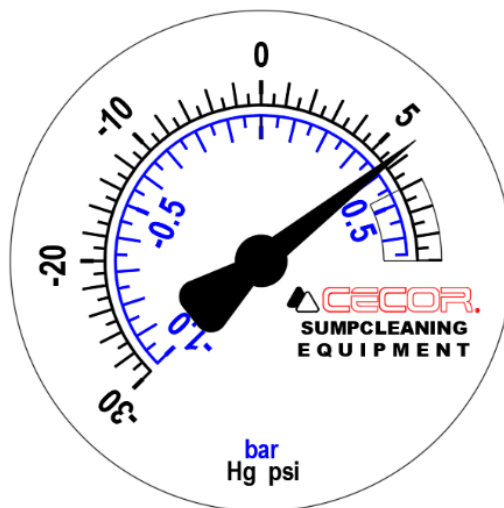

8. CLOSE AIR SUPPLY VALVE. TURN SELECTOR VALVE TO SUCTION. THE POSITIVE PRESSURE IN THE TANK WILL BE RELEASED THROUGH THE VACUUM SYSTEM. IF PRESSURE NEEDS TO BE RELIEVED FASTER RUN UNIT ON SUCTION MODE TILL GAUGE READS "0".
9. MACHINE IS READY TO USE.

## SECTION 4 – OPERATION

### 4.1 – CLEANING A SUMP

1. ATTACH THE SUMP CLEANER HOSE TO THE SUCTION PORT, CLOSE BOTH DISCHARGE PORT VALVES, AND SECURE THE FILL HATCH.
2. INSERT SUCTION TOOL INTO HOSE END.

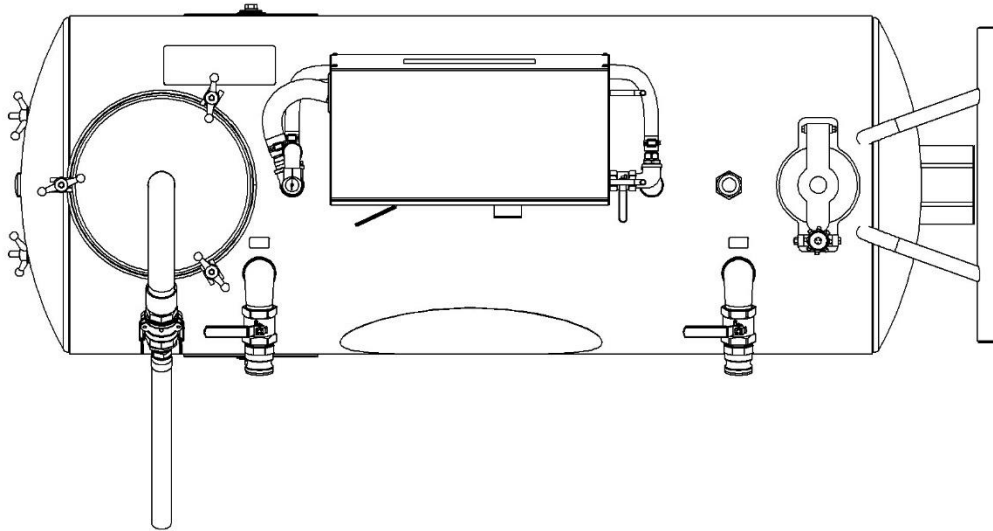

3. RUN UNIT ON SUCTION MODE. (SEE INITIAL STARTUP 3.3, STEP 3.)
4. WHEN VACUUMING OUT THE SUMP, ATTACK THE SOLIDS FIRST. POSITION THE SUCTION TOOL IN THE AREAS THAT ARE PRIMARILY SOLIDS. OCCASIONALLY MOVE THE SUCTION TOOL FROM THE SOLID PARTICULATE IN THE SUMP BOTTOM TO A PRIMARILY FLUIDIC AREA. THIS ACTION WILL CLEAR THE HOSE OF SOLIDS REDUCING THE CHANCES OF POSSIBLY PLUGGING THE HOSE.
5. WHEN THE TANK IS FULL, THE FLOAT CONTROL (LOCATED INSIDE THE SUMP CLEANER) WILL CUT OFF SUCTION TO THE PUMP ISOLATING THE PUMP FROM THE TANK (PUMP WILL KEEP RUNNING). WHEN THIS HAPPENS, THE VACUUM READING WILL FALL TO ZERO INDICATING THE TANK NEEDS TO BE EMPTIED.
5. WHEN THE FILTER IS FULL OR BLINDED, THE VACUUM/PRESSURE GAUGE WILL READ 10”+ HG, BUT THERE WILL BE NO SUCTION AT THE NOZZLE INDICATING THE FILTER NEEDS TO BE EMPTIED.

## 4.2 – DISCHARGING FLUID FROM THE DIRTY TANK

1. ATTACH THE SUMP CLEANER HOSE TO THE DISCHARGE PORT, CAP THE SUCTION PORT, CLOSE THE VALVE ON THE CLEAN TANK DISCHARGE PORT, AND SECURE THE FILL HATCH.

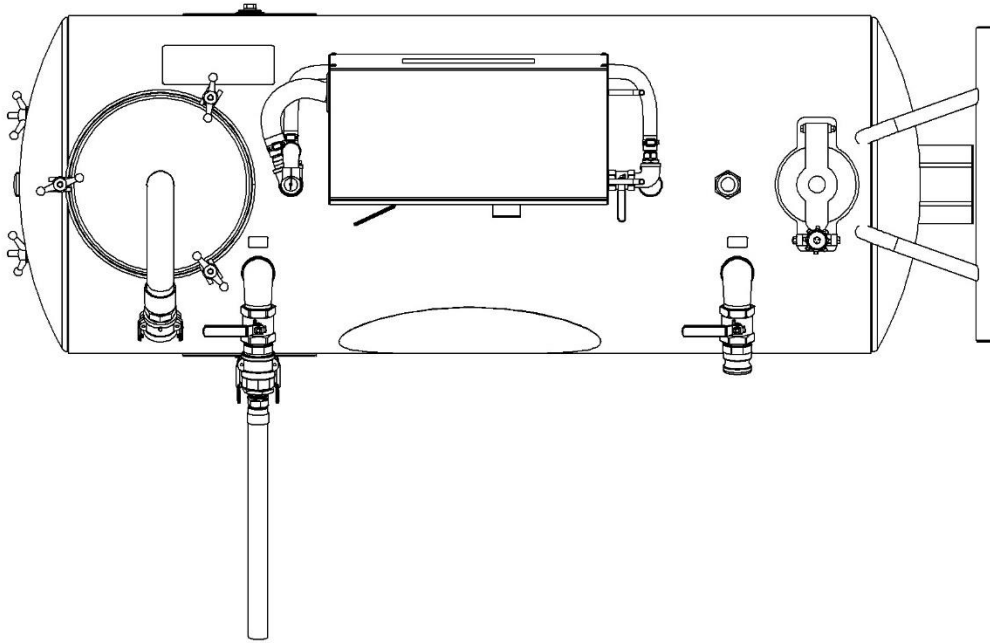

2. RUN UNIT ON DISCHARGE MODE. (SEE INITIAL STARTUP 3.3, STEP 6.)
3. POINT NOZZLE AT THE TARGET WHERE THE FLUID IS TO BE DISPENSED, SLOWLY OPEN DISCHARGE VALVE. SLUGS OF AIR WILL PASS THROUGH HOSE WHEN TANK APPROACHES EMPTY. THESE SLUGS CAN CAUSE ERRATIC FLUID FLOWS, BE PREPARED TO SHUT OFF DISCHARGE VALVE WHEN THIS OCCURS.
4. WHEN FINISHED DISCHARGING LIQUID, WHILE KEEPING THE HOSE CONNECTED TO THE DISCHARGE PORT, SWITCH UNIT BACK TO SUCTION AND TURN ON TO CLEAR THE HOSE OF ANY REMAINING LIQUID.

### 4.3 – FILLING CLEAN TANK WITH COOLANT

1. WHILE AIR SUPPLY VALVE IS CLOSED, OPEN CLEAN TANK FILL HATCH AND FILL. DO NOT OVER FILL.

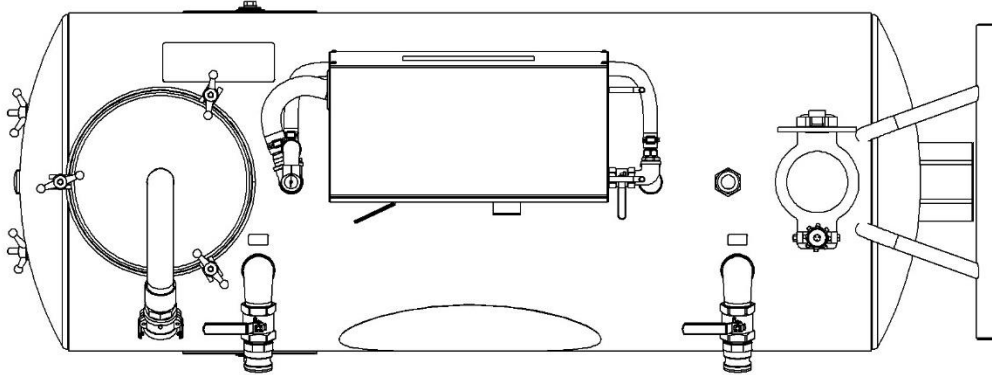

2. FILL TANK TO DESIRED LEVEL USING THE TANK FILL GAUGE.
3. SECURE THE FILL HATCH WHEN DONE FILLING.



#### 4.4 – DISCHARGING FLUID FROM THE SUMP CLEANER CLEAN TANK

1. ATTACH THE SUMP CLEANER HOSE TO THE DISCHARGE PORT OF THE CLEAN TANK, AND CAP THE SUCTION PORT. CLOSE ALL OTHER PORTS.

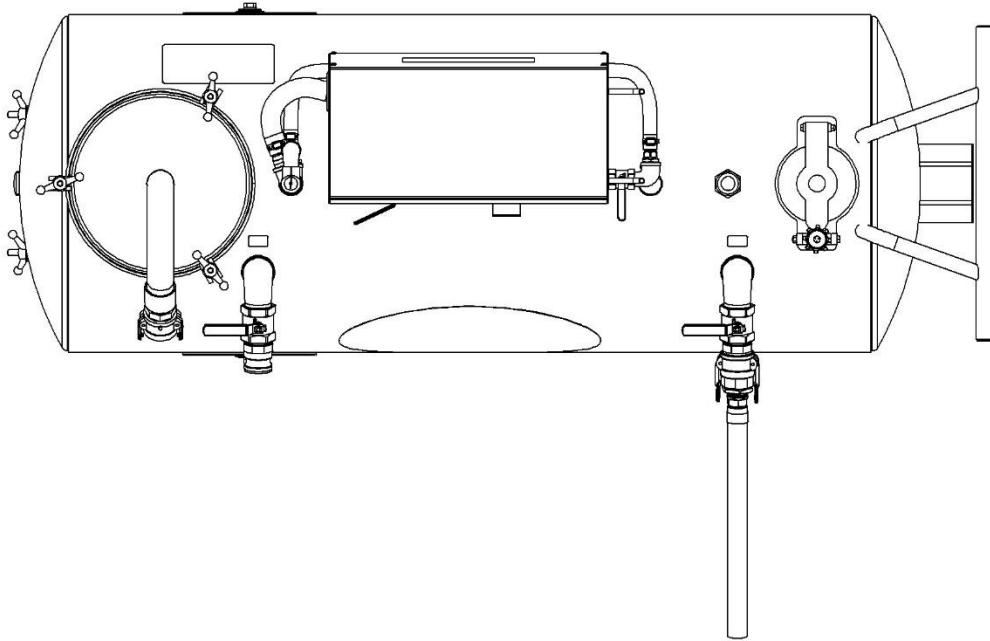

2. RUN UNIT ON DISCHARGE MODE. (SEE INITIAL STARTUP 3.3, STEP 6.)
3. POINT NOZZLE AT THE TARGET WHERE THE FLUID IS TO BE DISPENSED, SLOWLY OPEN DISCHARGE VALVE. SLUGS OF AIR WILL PASS THROUGH HOSE WHEN TANK APPROACHES EMPTY. THESE SLUGS CAN CAUSE ERRATIC FLUID FLOWS, BE PREPARED TO SHUT OFF DISCHARGE VALVE WHEN THIS OCCURS.
4. WHEN FINISHED DISCHARGING LIQUID, WHILE KEEPING THE HOSE CONNECTED TO THE DISCHARGE PORT, SWITCH UNIT BACK TO SUCTION AND TURN ON TO CLEAR THE HOSE OF ANY REMAINING LIQUID.

## 4.5 – FILTER

1. FILTERING OF THE FLUID IS SPECIFIC TO YOU. SUMP CONDITIONS VARY DUE TO ALL THE VARIABLES THAT OCCUR IN A MACHINE-TOOL SUMP. WE INCLUDE MULTIPLE FILTER BAGS SO YOU CAN FIND WHAT WORKS BEST FOR YOUR APPLICATION. FIRST-CLEANING CAN BE ESPECIALLY DIFFICULT IF IT HAS NOT BEEN DONE ON A REGULAR BASIS. WE SUGGEST STARTING WITH A COARSER BAG. ONCE ON A ROUTINE BASIS, A FINER FILTER CAN BE USED.
2. FILTERS ARE REUSABLE AND WASHABLE IN LUKEWARM WATER.
3. MAKE SURE THAT PRESSURE IN SUMP CLEANER TANK IS RELIEVED BEFORE EMPTYING FILTER.

### 4.5.1 – F10 FILTER

#### 4.3.1.1 – EMPTYING FILTER

1. FOR BEST RESULTS, DISCHARGE LIQUID FROM SUMP CLEANER AND LET FILTER DRAIN FOR A FEW MINUTES BEFORE DUMPING.
2. LOOSEN THE THREE (3) WING NUTS HOLDING THE POT LID IN PLACE.

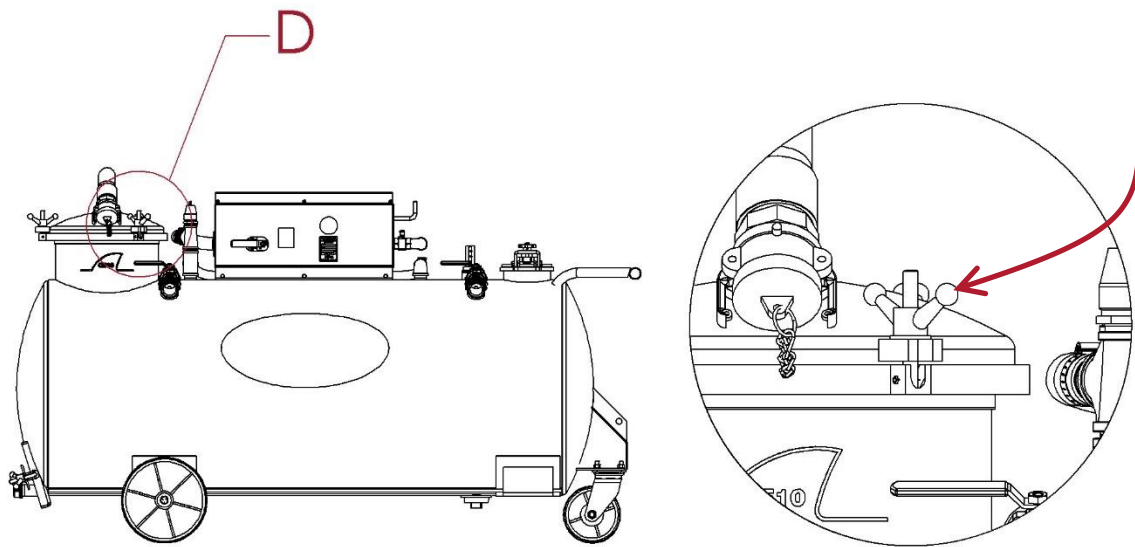

DETAIL D

SCALE 1 : 6

3. REMOVE FILTER. USE THE SIDES OF THE COARSE AND FINE FILTERS TO LIFT. FOR POLY FILTER, USE THE HANDLES ON SIDES AND BOTTOM TO REMOVE.

#### 4.5.1.2 – INSTALLING FILTER

1. PLACE EMPTY FILTER IN METAL PERFORATED BASKET.

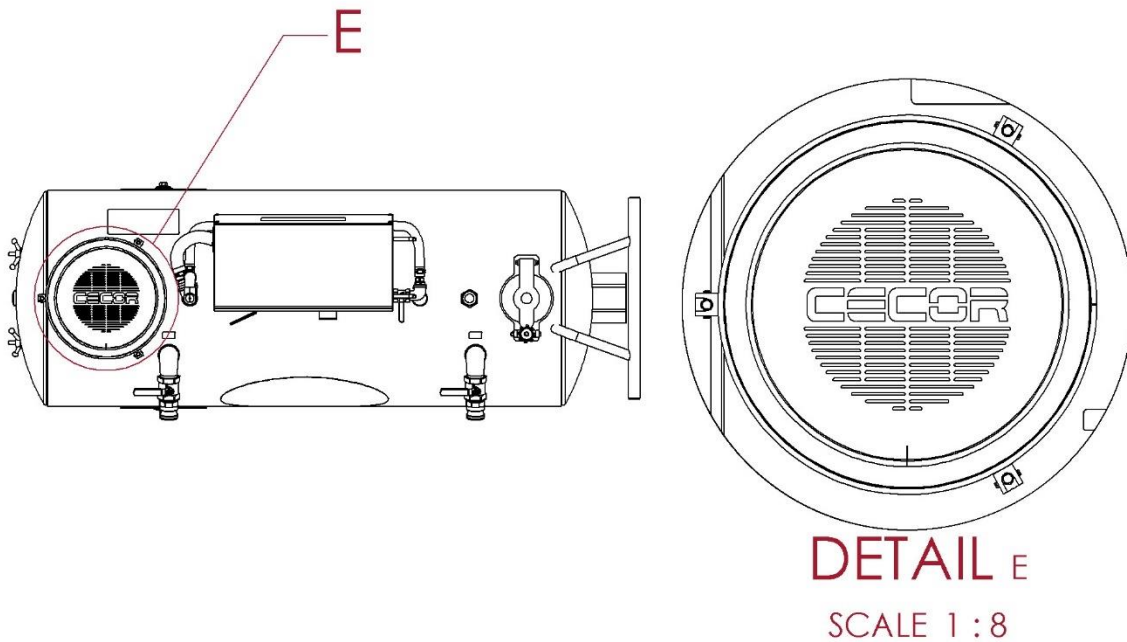

2. TUCK HANDLES IN BETWEEN FILTER AND PERFORATED BASKET. MAKE SURE COTTON BANDING(POLY-FILTER) OR SIDES OF FILTER ARE LYING ON POT LID GASKET COMPLETELY WITHOUT CREASES.
3. RE-INSTALL POT LID AND WING NUTS.
4. WITH UNIT IN SUCTION MODE AND POT LID CAPPED, TURN UNIT ON AND TO TIGHTEN WING NUTS. THIS PROVIDES EQUAL PRESSURE ON THE POT LID GASKET CREATING BEST SEAL.

## 4.5.2 – F23 FILTER

### 4.5.2.1 – EMPTYING FILTER

1. FOR BEST RESULTS, DISCHARGE LIQUID FROM SUMP CLEANER AND LET FILTER DRAIN FOR A FEW MINUTES BEFORE DUMPING.
2. LOOSEN THE THREE WING NUTS ON FILTER ASSEMBLY.

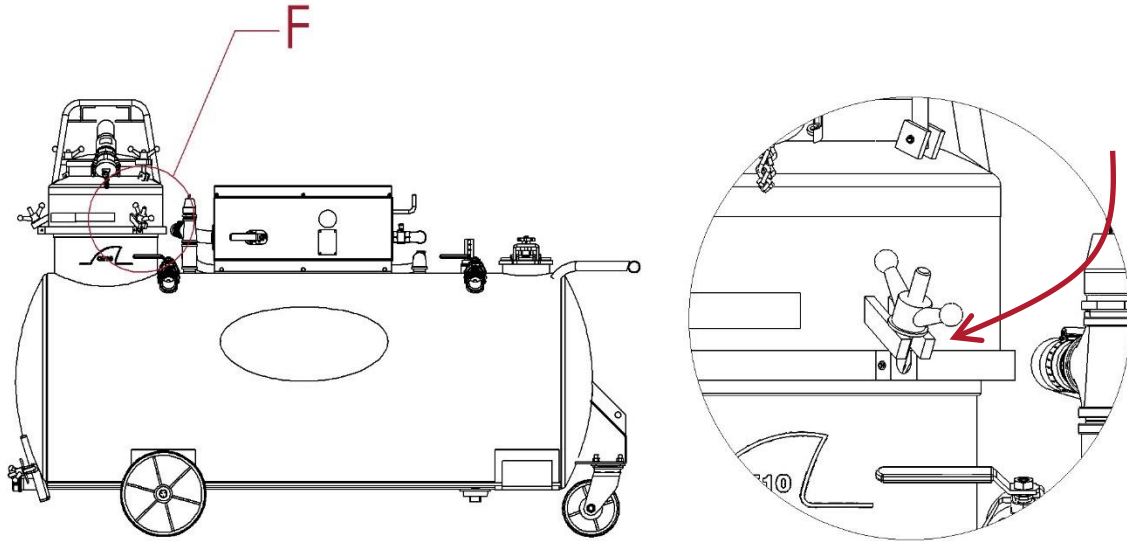

DETAIL F

SCALE 1 : 6

3. LIFT FILTER OUT OF SUMP CLEANER TANK USING HOIST OR FORKLIFT. CAUTION: KEEP HANDS AND FINGERS CLEAR OF POT OPENING IN SUMP CLEANER WHEN REMOVING FILTER!

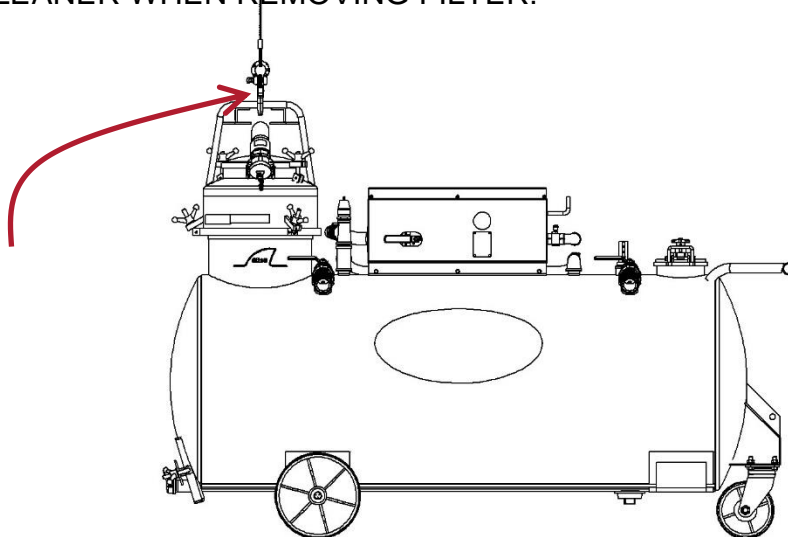

4. POSITION FILTER ABOVE CONTAINER INTO WHICH THE SLUDGE IS TO BE EMPTIED. DISTANCE BETWEEN BOTTOM OF FILTER AND CONTAINER BOTTOM OR "D" DIMENSION, SHOWN IN FIGURE BELOW, AND SHOULD BE APPROXIMATELY 2 TO 3 FEET ON F23 TO PREVENT DAMAGE TO FILTER SLEEVE WHEN DUMPED. DRAINING FILTER BEFORE POSITIONING AND USING A CONTAINER WITH A DRY BOTTOM AND SUITABLE CAPACITY WILL HELP REDUCE POSSIBLE FILTER SPLASH BACK.

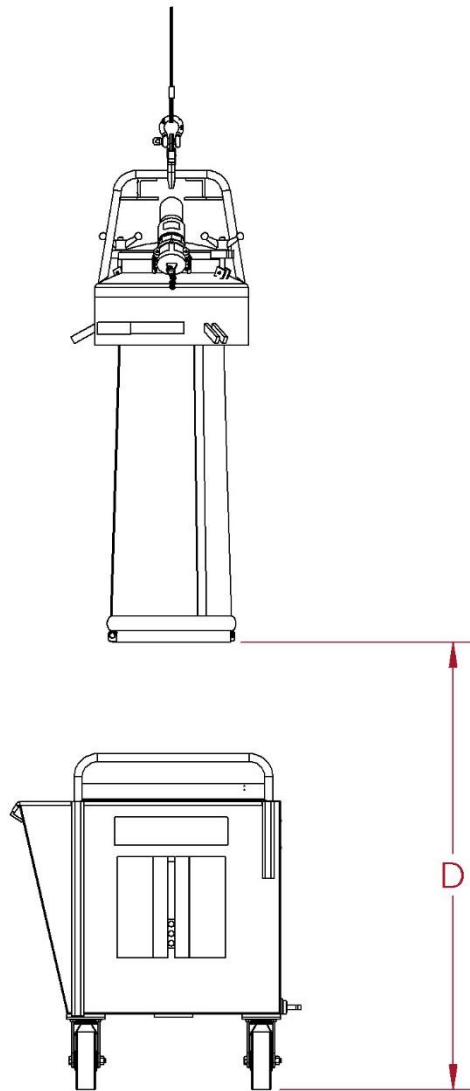

5. ATTACH LANYARD TO TRIGGER ASSEMBLY ON FILTER BOTTOM.

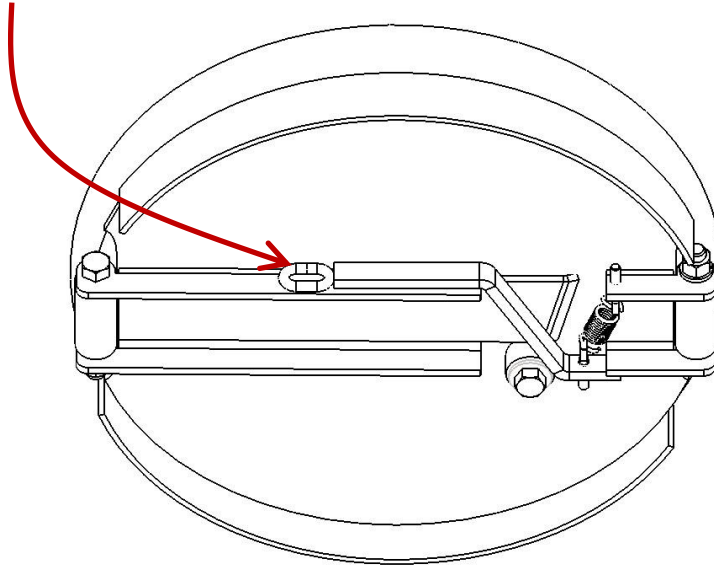

6. MOVE TO A SAFE DISTANCE FROM THE DUMPING ZONE (APPROXIMATELY 7 FEET).
7. PULL LANYARD TO RELEASE LATCH AND BOTTOM DOOR WILL OPEN DUMPING THE FILTER.
8. AFTER FILTER SLEEVE IS EMPTY, ROLL BOTTOM OF SLEEVE UP LOOSELY SO THAT THE BOTTOM END OF SLEEVE WILL BE CLOSED AND CLOSE BOTTOM DOOR.

#### 4.5.2.2 - INSTALLING FILTER

1. LOOSEN THE TWO WING NUTS ON THE FILTER LID AND REMOVE LID.

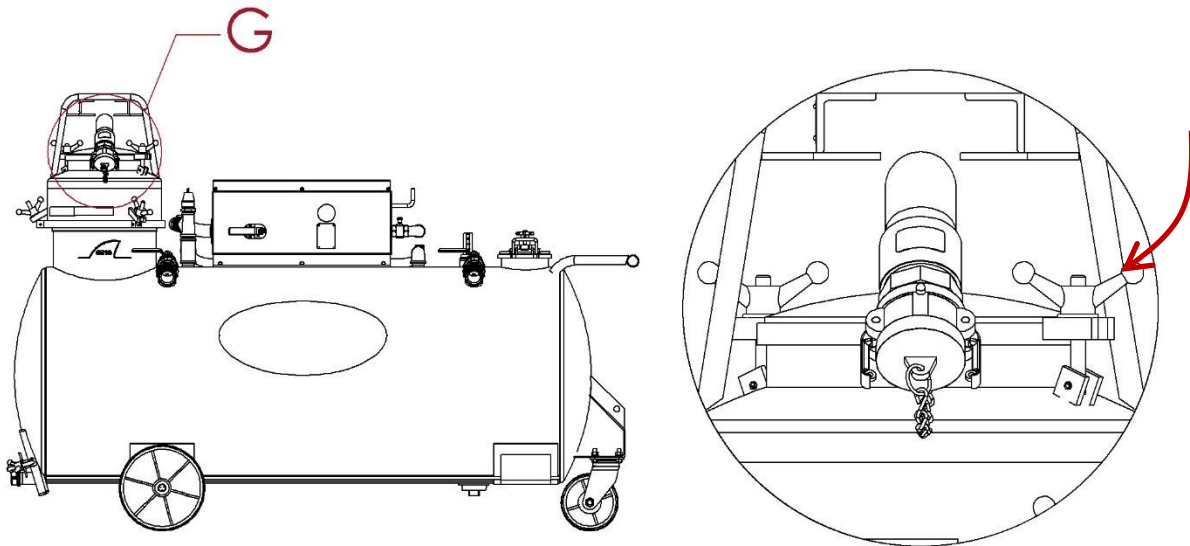

DETAIL G

SCALE 1 : 6

2. PLACE BOTTOM END OF FILTER SLEEVE IN FILTER.
3. FOLD UPPER 1 ½" OF FILTER SLEEVE COLLAR OUT OVER LIP OF FILTER SO THAT THE GASKET IN LID WILL CLAMP IT IN PLACE.
4. REPLACE FILTER LID AND TIGHTEN WING NUTS SECURELY.
5. SUSPEND FILTER FROM HOIST OR FORKLIFT. OPEN FILTER DOOR.
6. PULL BOTTOM END OF FILTER SLEEVE DOWN AND FOLD UP LOOSELY SO THAT BOTTOM END OF SLEEVE WILL BE CLOSED.
7. PLACE FILTER IN SUMP CLEANER AND TIGHTEN THE WING NUTS SECURELY.

#### 4.4 – CLEANING THE SUMP CLEANER

1. GENERALLY, DISCHARGING THE FLUID OUT OF THE SUMP CLEANER IS ALL THAT'S NEEDED. SOME SOLIDS WILL ACCUMULATE IN THE BOTTOM OF THE SUMP AND WILL REQUIRE A COMPLETE CLEANOUT OCCASIONALLY.
2. THE SA5 HAS AN EASY TO REMOVE CLEANOUT DOOR AND CAN ACCESSED BY LOOSENING THE TWO WINGNUTS.

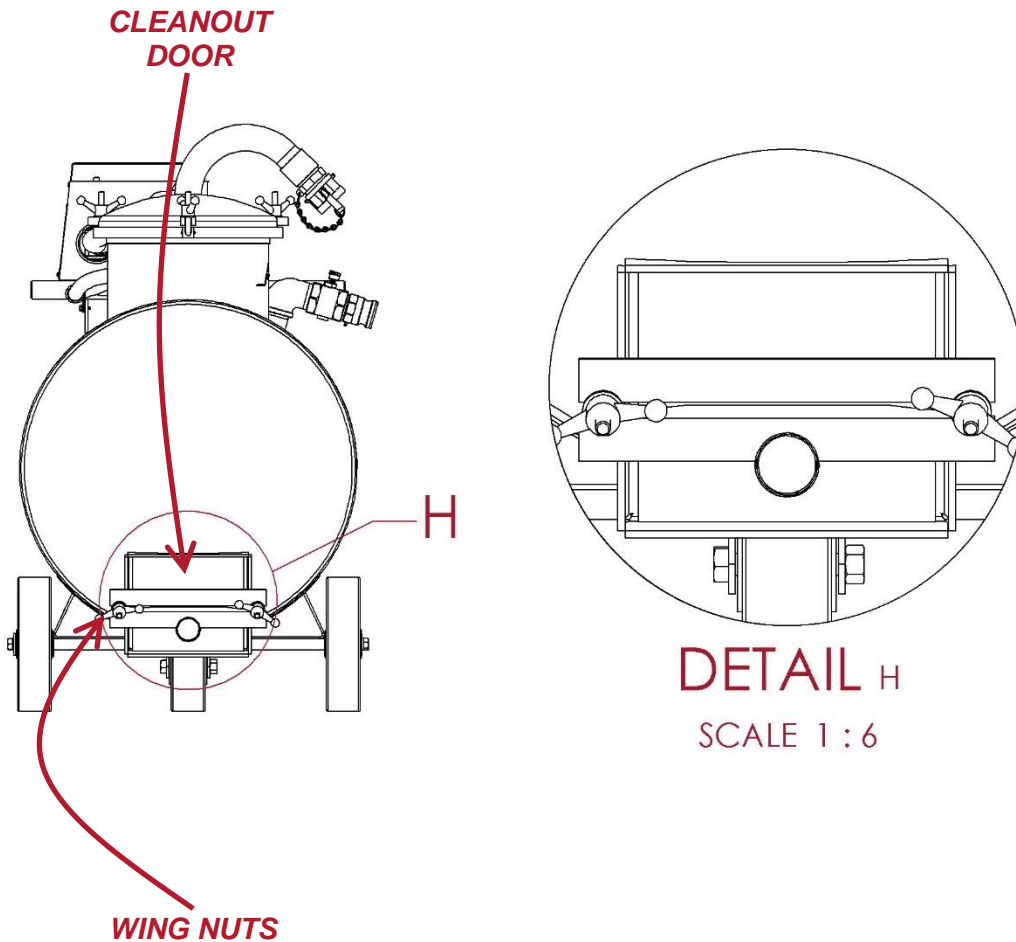



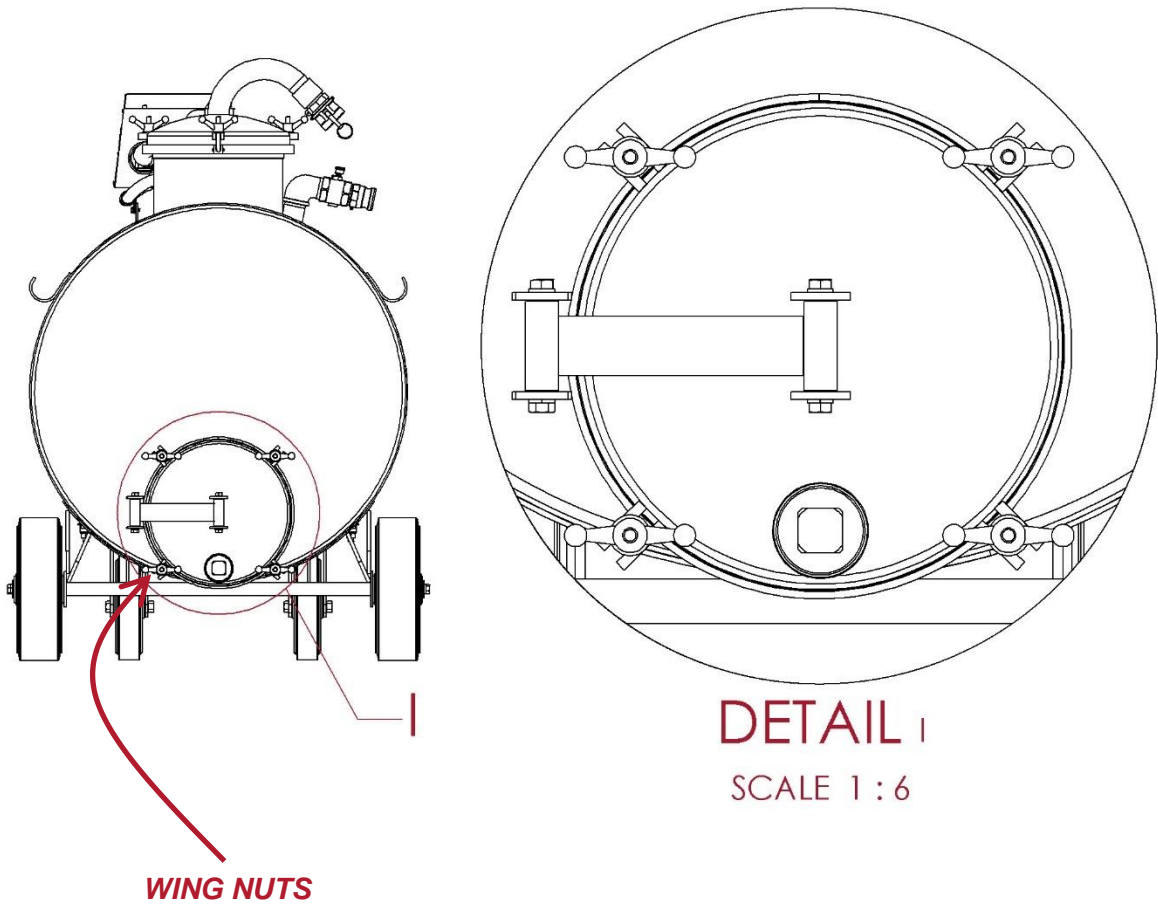

## SECTION 5 – MAINTENANCE

TO GET THE HIGHEST PERFORMANCE FROM YOUR SUMP SHARK, IT IS IMPORTANT TO KEEP IT WELL MAINTAINED. BELOW IS A MAINTENANCE GUIDE THAT WILL KEEP YOUR SUMP CLEANER IN TOP-NOTCH, DEPENDABLE CONDITION. ANY WORN OR DAMAGED PART SHOULD BE REPLACED IMMEDIATELY. CECOR STOCKS SUMP CLEANER PARTS AND MOST CAN BE SHIPPED THE SAME OR THE NEXT DAY. CALL 1-800-356-9042 TO ORDER PARTS.

### 5.1 – DAILY MAINTENANCE

1. CHECK THE VACUUM/PRESSURE GAUGE TO SEE THAT IT IS OPERATING AND READING CORRECTLY. TANK PRESSURE SHOULD NOT EXCEED PRESSURES OF 7 PSI.
2. DEFECTIVE RELIEF VALVES SHOULD BE REPLACED IMMEDIATELY.
3. CHECK FOR GASKET LEAKS AND ANY TANK DAMAGE.

### 5.2 – WEEKLY MAINTENANCE

1. INSPECT TANK FOR SLUDGE BUILD UP. CLEAN TANK IF NECESSARY. WITH SOME APPLICATIONS, THE TANK MAY NEED TO BE CLEANED MORE FREQUENTLY. ALWAYS CLEAN THE TANK BETWEEN PUMPING DIFFERENT TYPES OF FLUIDS OR MATERIALS.
2. CLEAN AND INSPECT TANK FLOAT CONTROL. SEE THAT THE FLOAT BALL SEALS AGAINST THE GASKET. THE FLOAT CONTROL ASSEMBLY CAN BE ASSESSED THROUGH THE POT OPENING IN THE SUMP CLEANER.
3. CLEAN THE FILTER BAG BY RINSING IT OUT IN LUKEWARM WATER.
4. OPERATE THE 8 PSI PRESSURE RELIEF HANDLE TO MAKE SURE IT IS WORKING.

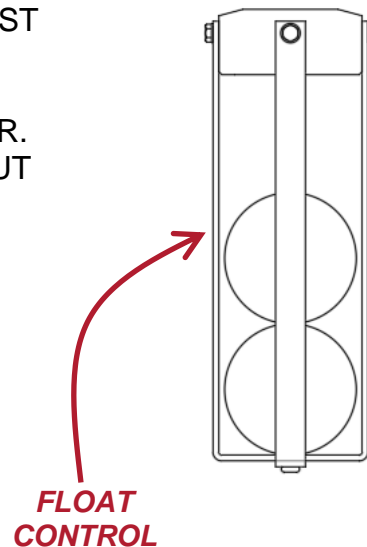

### **5.3 – MONTHLY MAINTENANCE**

1. CHECK FOR WEAR ON POT LID WING NUTS AND STUDS.
2. INSPECT SUMP CLEANER HOSE.
3. GREASE THE SWIVEL CASTER AND WHEELS.
4. CHECK FRONT CASTER BOLTS AND WHEEL BOLTS AND TIGHTEN IF NECESSARY.

## SECTION 6 – TROUBLESHOOTING

PROBLEM	POSSIBLE CAUSES	CORRECTIVE ACTION
Will not start	Air Supply	Make sure the unit is connected to an adequate air supply.
	Hose Restrictions	Check air lines for kinks or other restrictions.
	Blockage of Air Flow	Check for debris that may have come through the air line.
Loss of suction	Vac/pres gauge reads full vacuum but has no suction.	Check filter. If full, empty. If blinded, clean or go to a coarser filter bag.
		Check hose for blockage.
		Check gauge; replace if needed.
	Vac/pres gauge reads "0" vacuum.	Tank is full; empty tank.
		Make sure discharge valve is closed.
		Air leakage; check gaskets and loose connections.
		Check tank selector valve and air supply
	Vac/pres gauge reads Low suction.	Check for correct size air connections.
		1/2 air-lines should not exceed 40'.
		Check for air flow out of the muffler.
Check tank selector valve and air supply for being completely open.		
Will not discharge	Vac/Pres gauge reads "6" psi.	Check discharge hose for blockage.
		Check for a build up of fines in tank bottom; clean if necessary.
	Vac/Pres gauge reads "0" psi.	Check that cap is on suction port.
		Air leakage; check gaskets and loose connections.
Fluid coming out of "Discharge" Tank-to - Pump connection.	Float Control	Check float control; clean or replace.
	Excessive Foaming	Consult coolant supplier.
	Tank Turbulence	Check to see if air is being sucked in the discharge.

## SECTION 7 – REPAIR PARTS LIST

### 7.1 – SUMP CLEANER

#### 7.1.1 WHEELS - “PTL” PUSH TOW LIFT TRANSPORT 100/100 GAL

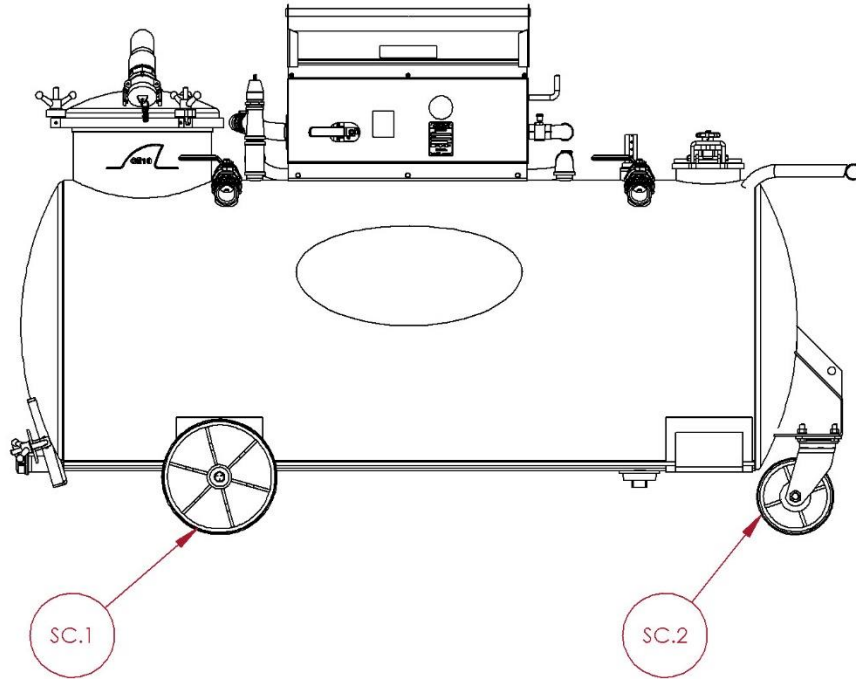

REF	PART NUMBER	DESCRIPTION
SC.1	PCST.WHEL.1201.0KIT	WHEEL - POLY 12" x 3"
SC.2	PCST.SWIV.0803.0000	CASTER - POLY SWIVEL 8" x 3"

## 7.1.2 WHEEL "TW" TOW TRANSPORT 150/150 & 200/200 GAL

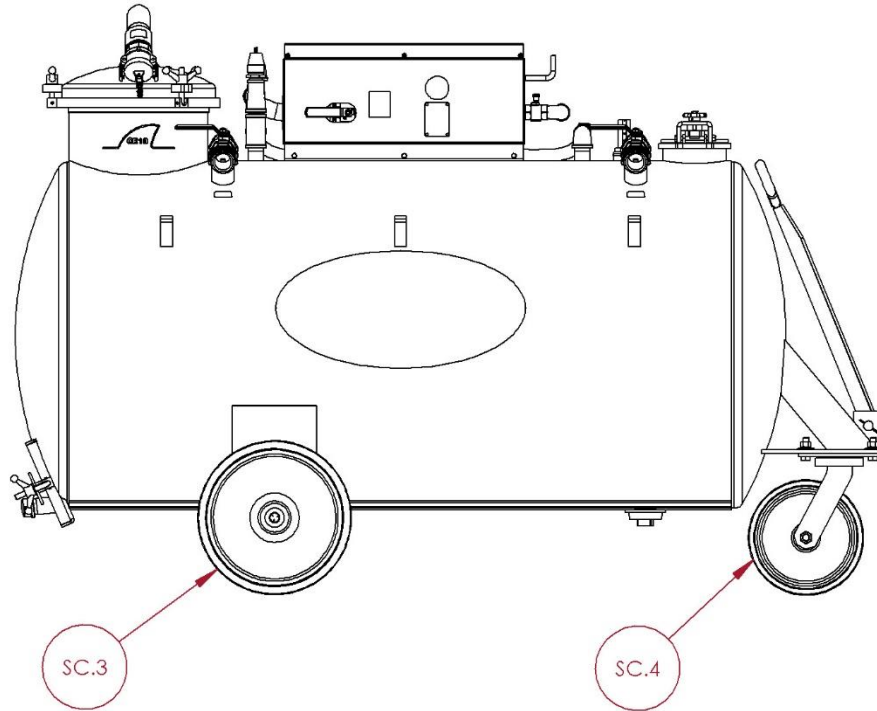

REF	PART NUMBER	DESCRIPTION
SC.3	PCST.WHEL.1602.0000	WHEEL - POLY 16" x 4"
SC.4	PCST.SWIV.1203.0000	CASTER - POLY SWIVEL 12" x 3"

### 7.1.3 WHEEL "TW" TOW TRANSPORT 250/250 GAL

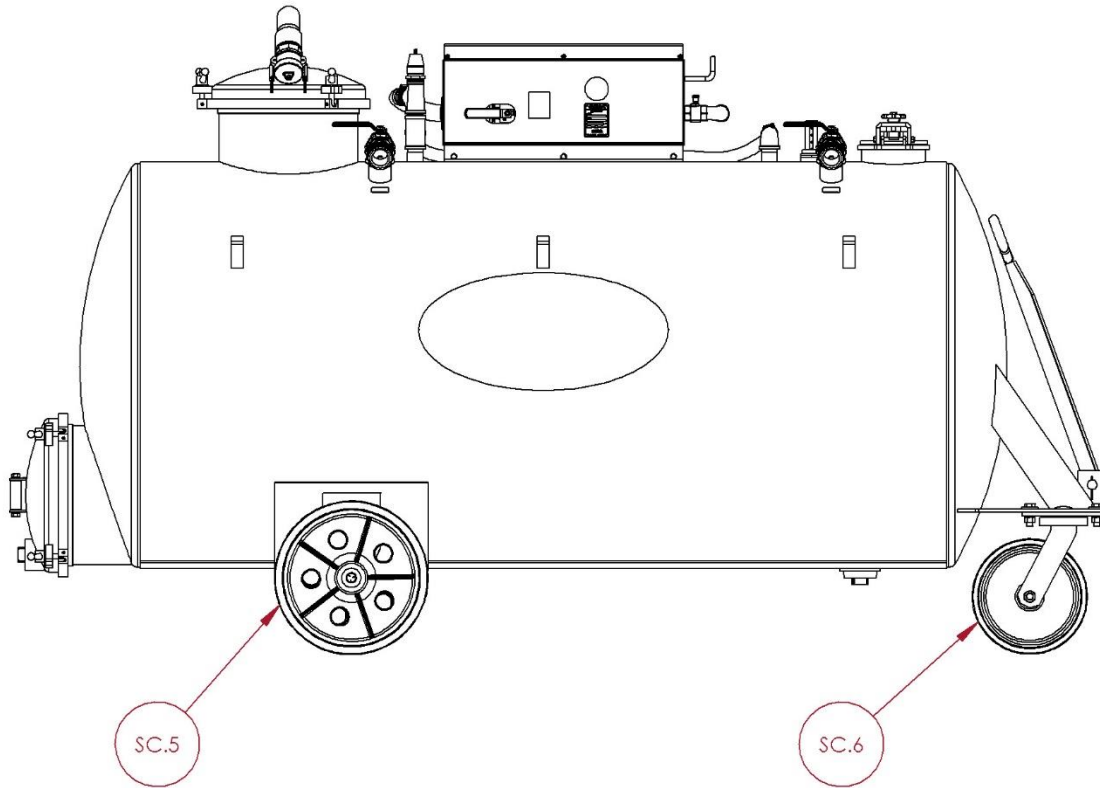

REF	PART NUMBER	DESCRIPTION
SC.5	PCST.WHEL.1603.0000	WHEEL - POLY 16" x 5"
SC.6	PCST.SWIV.1203.0000	CASTER - POLY SWIVEL 12" x 3"

## 7.2 – TANK

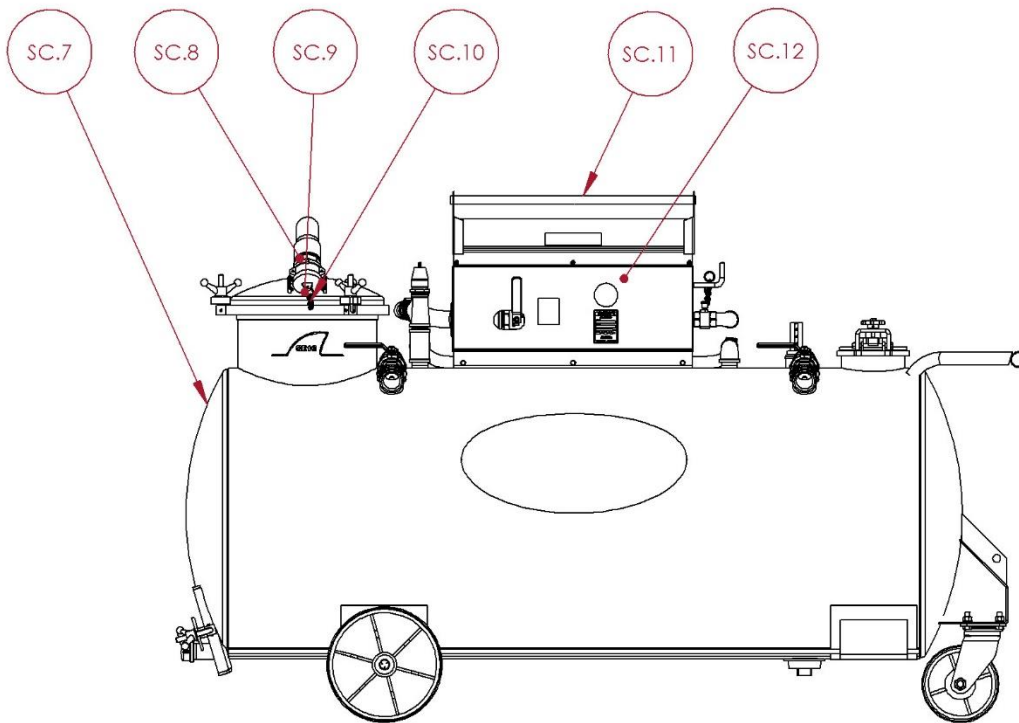

REF	PART NUMBER	DESCRIPTION
SC.7	CALL FOR INFO	TANK ASSEMBLY
SC.8	PPLM.0000.0050.0000	PRESSURE SAFE ADAPTER - 2" - MALE
SC.9	PPLM.0000.0049.0000	CAP - PRESSURE SAFE 2"
SC.10	PMIS.0000.0008.0000	CHAIN, SECURITY W/SMALL HOOKS 6"
SC.11	ASC0.0087	TOOL BOX ASSEMBLY
SC.12	SA5-H	SA5-H PUMP ASSEMBLY



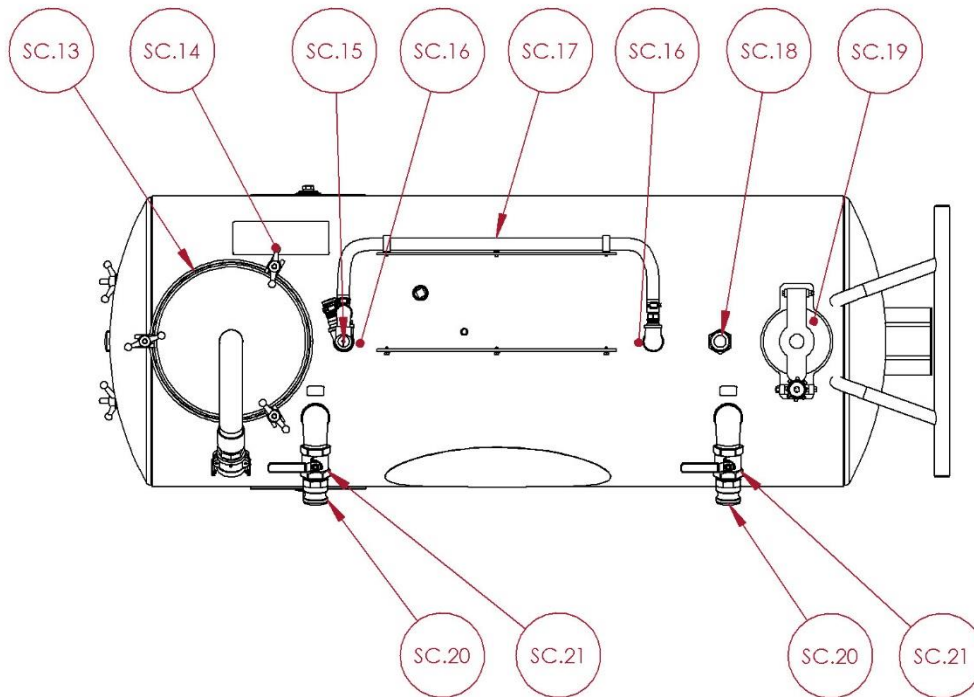

REF	PART NUMBER	DESCRIPTION
SC.13	ADT0.0016	GASKET - 16" DIA
SC.14	HN0Z.0500.1300.WING	WING NUT ½-13
SC.15	PVAL.RELF.0005.0000	VALVE - PRESSURE RELIEF
SC.16	ASC0.0001	FLOAT CONTROL (2 BALLS) 1¼"
SC.17	RHO0.1000.0048.0000	TANK CONNECTION HOSE
SC.18	PPLM.0000.0026.0000	GAUGE, LIQUID LEVEL (100/100 & 150/150)
SC.18	PPLM.0000.0027.0000	GAUGE, LIQUID LEVEL (200/200, 250/250, 300/300)
SC.19	PGAS.0000.0008.0600	GASKET - 6" FILL HATCH
SC.20	PVAL.BTFY.0005.0000	VALVE - BUTTERFLY 2"
SC.21	PPLM.0000.0031.0000	DISCONNECT ADAPTER - 2" - MALE

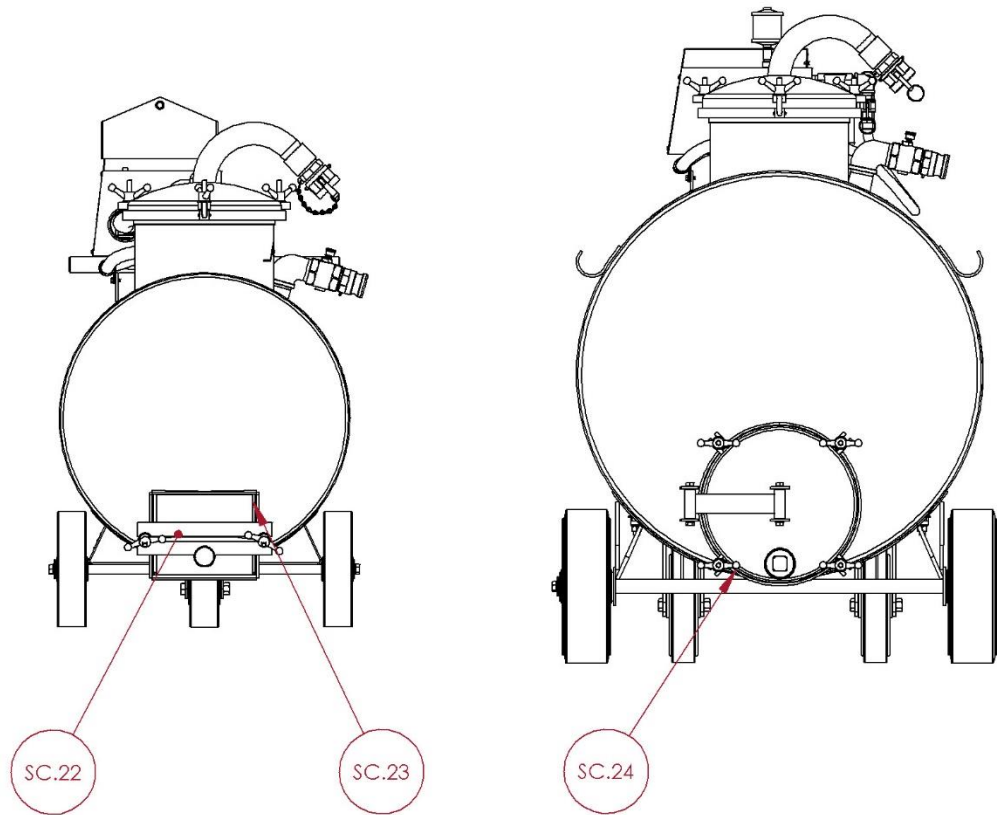

REF	PART NUMBER	DESCRIPTION
SC.22	ASC0.0043	RECTANGULAR CLEANOUT DOOR
SC.23	ADT0.0010	GASKET - RECTANGULAR
SC.24	ADT0.0016	GASKET - 16" DIA

### 7.3 – PUMP ASSEMBLY

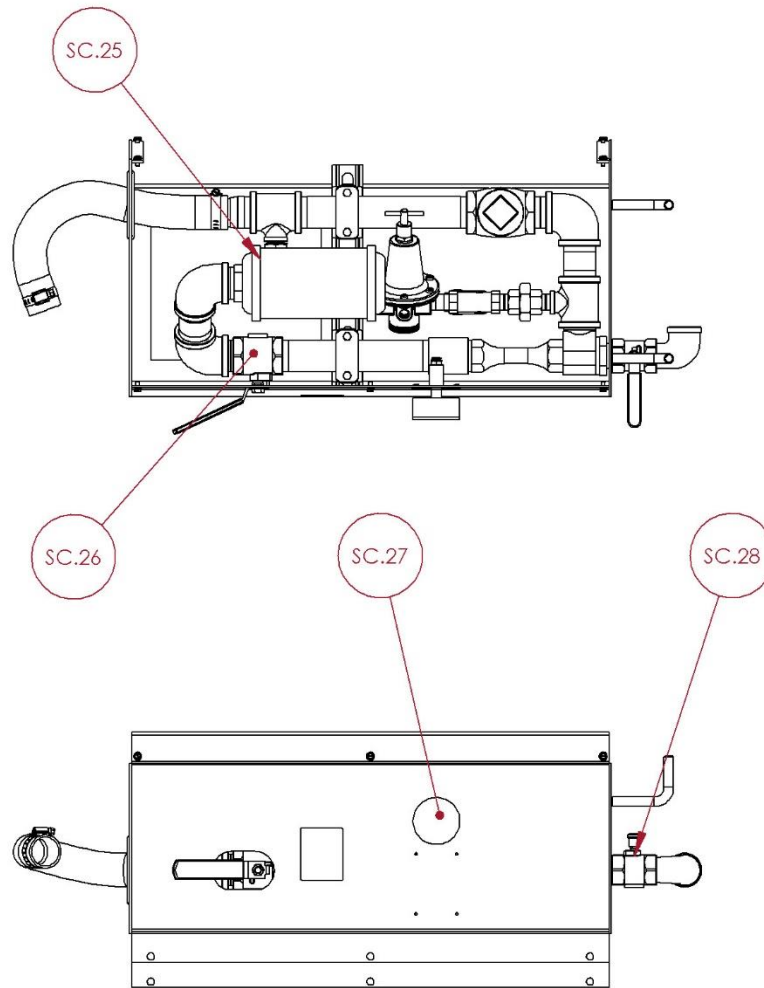

REF	PART NUMBER	DESCRIPTION
SC.25	PPLM.0000.0044.0000	MUFFLER
SC.26	PVAL.BTFY.0003.0000	SELECTOR VALVE
SC.27	PPLM.0000.0012.0000	GAUGE - VACUUM PRESSURE 2½" BACK MOUNT
SC.28	PVAL.BTFY.0002.0000	ON/OFF VALVE
SC.29	PHOS.EPDM.0001.0000	AIR HOSE 1/2" x 20' (NOT SHOWN)

## 7.4 – DISPENSER HOSE (STANDARD)

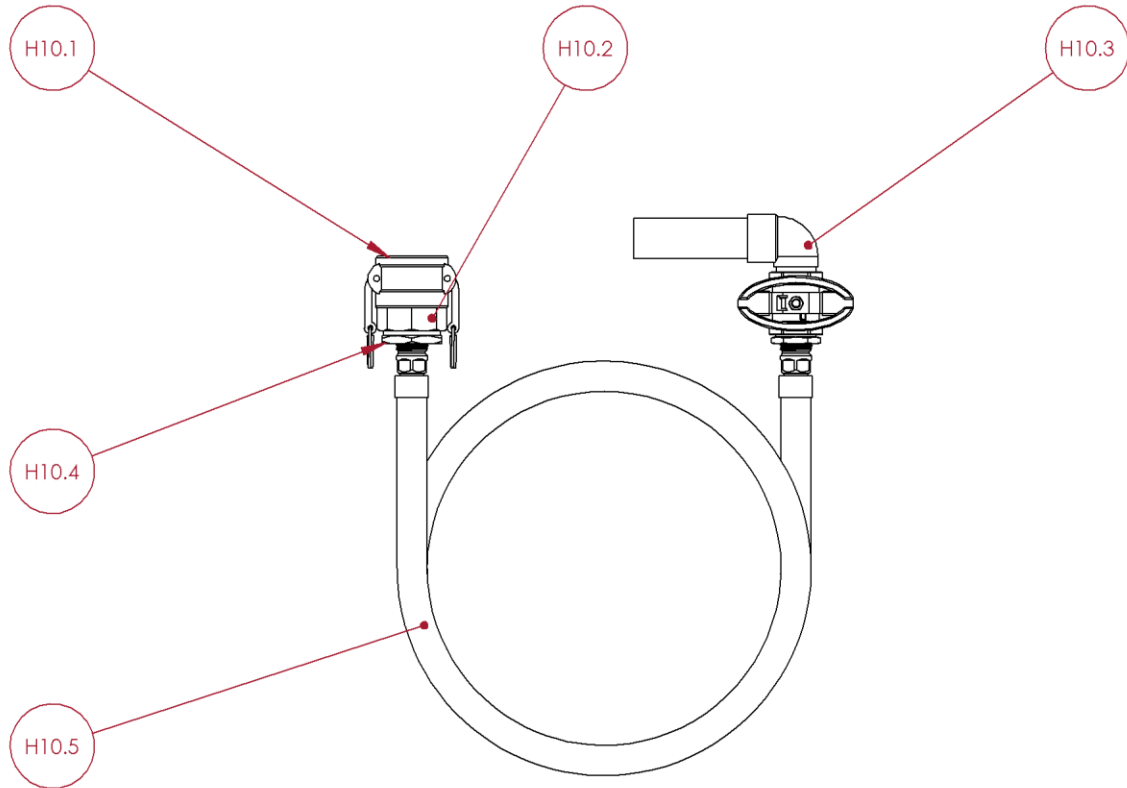

REF	PART NUMBER	DESCRIPTION
H10.1	PPLM.0000.0016.0000	QUICK DISCONNECT COUPLER
H10.2	PGAS.0000.0003.0200	COUPLER GASKET
H10.3	ASC0.0064	NOZZLE - VALVE ASSEMBLY 1"
H10.4	FBG0.2000.1000.0000	BUSHING - REDUCER
H10.5	ASC0.0028	HOSE ASSEMBLY - 1" x 16' - DISPENSER

## 7.5 – SUMP CLEANER HOSE 1-1/2" x 16' (STANDARD)

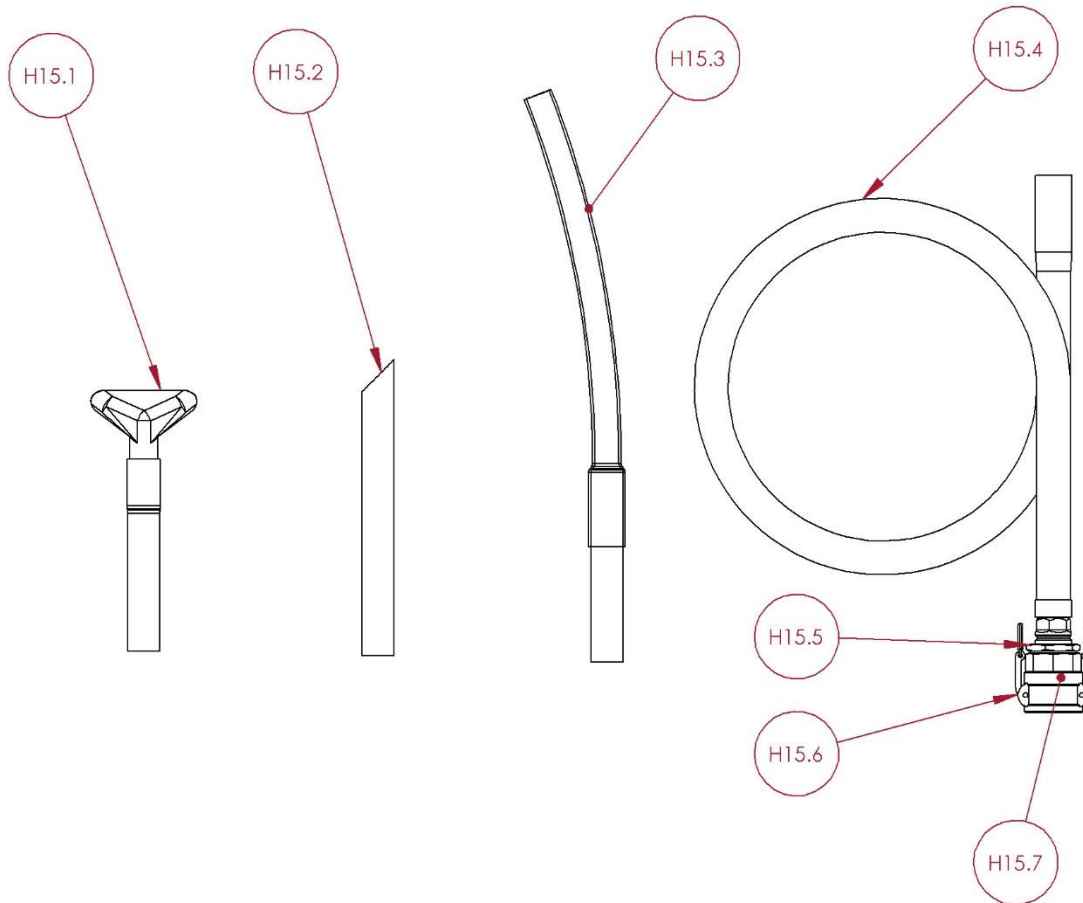

REF	PART NUMBER	DESCRIPTION
H15.1	ASC0.0032	TOOL - NOZZLE ASSEMBLY-FLARE 1-1/2"
H15.2	ADT0.0019	TOOL - NOZZLE - 1¼" STR.
H15.3	ASC0.0033	TOOL - NOZZLE ASSEMBLY-FLEXIBLE 1-1/2"
H15.4	ASC0.0025	HOSE ASSEMBLY - 1½" x 16' - SUMP CLEANER
H15.5	FBG0.2000.1500.0000	BUSHING - REDUCER
H15.6	PPLM.0000.0016.0000	QUICK DISCONNECT COUPLER
H15.7	PGAS.0000.0003.0200	COUPLER GASKET

## 7.6 – SUMP CLEANER HOSE 2" x 16' (OPTIONAL)

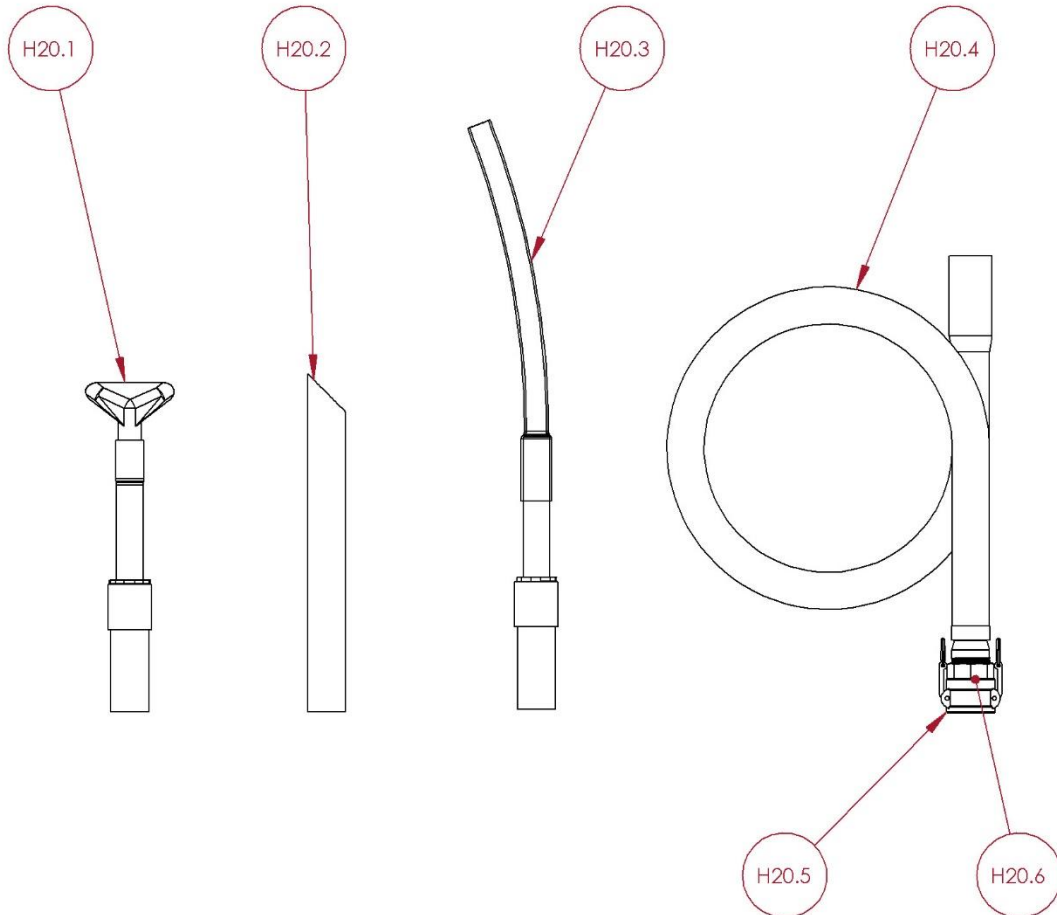

REF	PART NUMBER	DESCRIPTION
H20.1	ASC0.0034	TOOL - FLARED NOZZLE ASSEMBLY, 2" HOSE
H20.2	ADT0.0055	TOOL - STRAIGHT NOZZLE, 2"
H20.3	ASC0.0035	TOOL - FLEXIBLE NOZZLE ASSEMBLY, 2" HOSE
H20.4	ASC0.0030	HOSE ASSEMBLY - 2" x 16' - SUMP CLEANER
H20.5	PPLM.0000.0016.0000	QUICK DISCONNECT COUPLER
H20.6	PGAS.0000.0003.0200	COUPLER GASKET

## 7.7 – F10 FILTER (STANDARD)

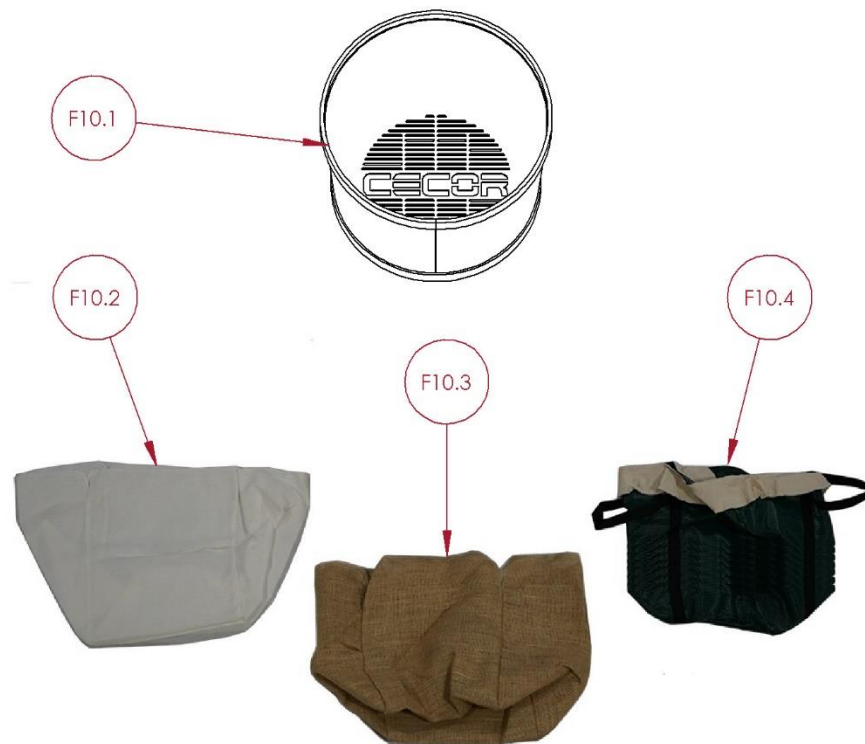

REF	PART NUMBER	DESCRIPTION
F10.1	ASC0.0005	F10 FILTER BASKET ASSEMBLY
F10.2	ADT0.0021	F10 FINE STRAINER BAG
F10.3	ADT0.0022	F10 COARSE STRAINER BAG
F10.4	ADT0.0023	F10 POLY STRAINER BAG

## 7.8 – F23 FILTER (OPTIONAL)

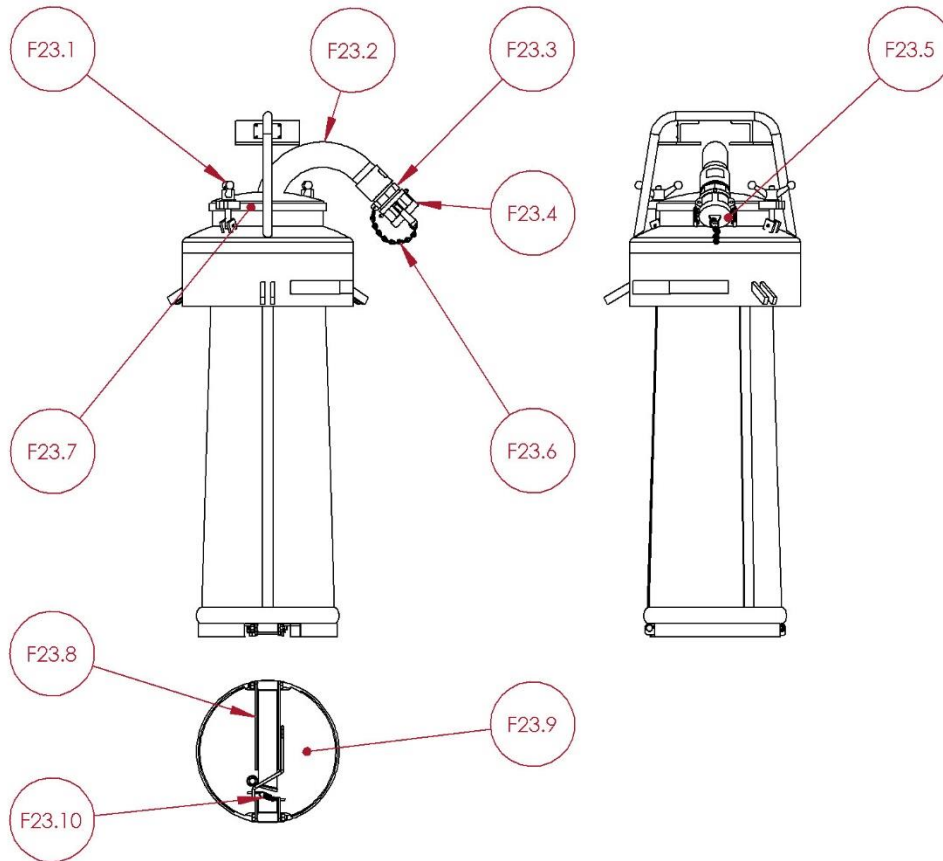

REF	PART NUMBER	DESCRIPTION
F23.1	HN0Z.0500.1300.WING	WING NUT ½-13
F23.2	ASC0.0051	FILTER LID ASSEMBLY
F23.3	PPLM.0000.0050.0000	PRESSURE SAFE ADAPTER - 2" - MALE
F23.4	PPLM.0000.0049.0000	CAP - PRESSURE SAFE 2"
F23.5	PGAS.0000.0003.0200	COUPLER GASKET
F23.6	PMIS.0000.0008.0000	CHAIN, SECURITY W/SMALL HOOKS 6"
F23.7	ADT0.0057	FILTER LID GASKET
F23.8	ADT0.0074	LATCH CHANNEL
F23.9	ASC0.0021.A	BOTTOM DOOR ASSEMBLY
F23.10	PFAB.0000.0030.0000	LOCKING SPRING
F23.11	ADT0.0173	F23 FILTER SLEEVE COARSE (NOT SHOWN)
F23.12	ADT0.0056	F23 FILTER SLEEVE GREEN POLY (NOT SHOWN)
F23.13	ADT0.0209	F23 FILTER SLEEVE FINE COTTON (NOT SHOWN)



## SECTION 8 – WARRANTY

### WARRANTY STATEMENT

PLEASE PRINT OUR WARRANTY AT [HTTPS://CECOR.NET/CECOR-WARRANTY/](https://cecor.net/cecor-warranty/)



## SECTION 9 – RECORD MODEL & SERIAL NUMBER

WHEN YOU RECEIVE YOUR CECOR SUMP SHARK, RECORD THE MODEL NUMBER, SERIAL NUMBER AND DATE DELIVERED FOR YOUR RECORDS.

<p><b>MODEL #:</b> _____</p> <p><b>SERIAL #:</b> _____</p> <p><b>DELIVERED:</b> _____ / _____ / _____</p>
---



**CECOR®**

