

2

1

B

B

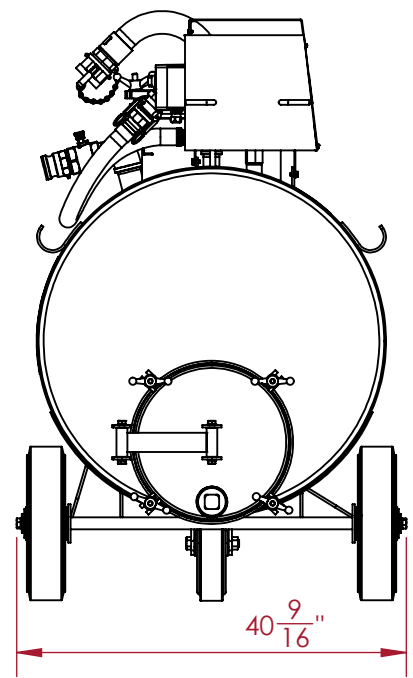
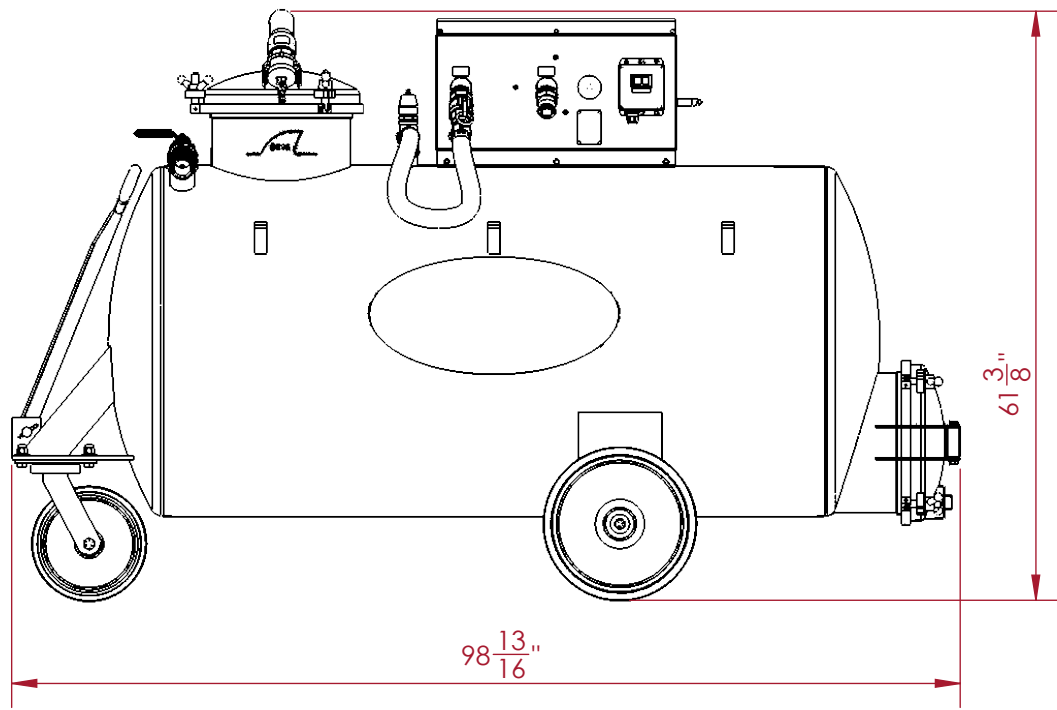

A

A

**CECOR**\* 1000 Jamse Ave.  
 Belleville, WI 53508  
 Phone: (608) 845-6771  
 Email: cecor@cecor.net

TITLE:  
**SE15-300TW-H-F10  
 STANDARD**

**PROPRIETARY AND  
 CONFIDENTIAL:**  
 THE INFORMATION  
 CONTAINED IN THIS  
 DRAWING IS THE SOLE  
 PROPERTY OF CECOR.  
 ANY REPRODUCTION IN  
 PART OR AS A WHOLE  
 WITHOUT THE WRITTEN  
 PERMISSION OF CECOR  
 IS PROHIBITED.

UNITS: INCHES  
 TOLERANCES:  
 FRAC: ± 1/4"

DRAWN: BY BPU DATE 07/18/24	DWG. NO. ASC0.0271	REV 0
---	-----------------------	----------

CUSTOMER SIGN OFF: \_\_\_\_\_ DATE: \_\_\_\_\_

2

1

2

1

B

B

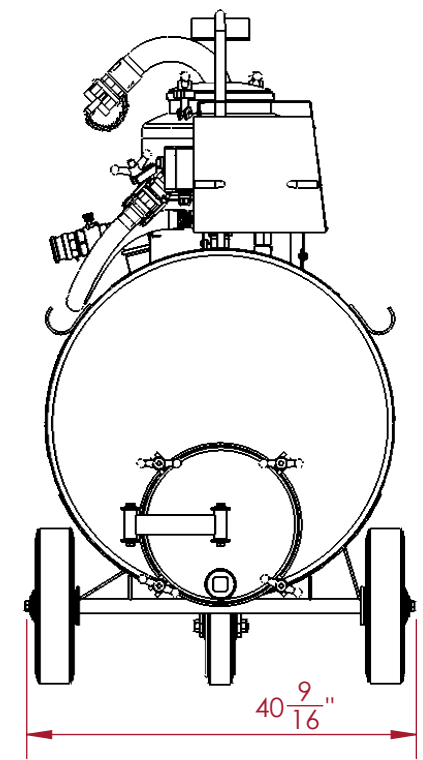
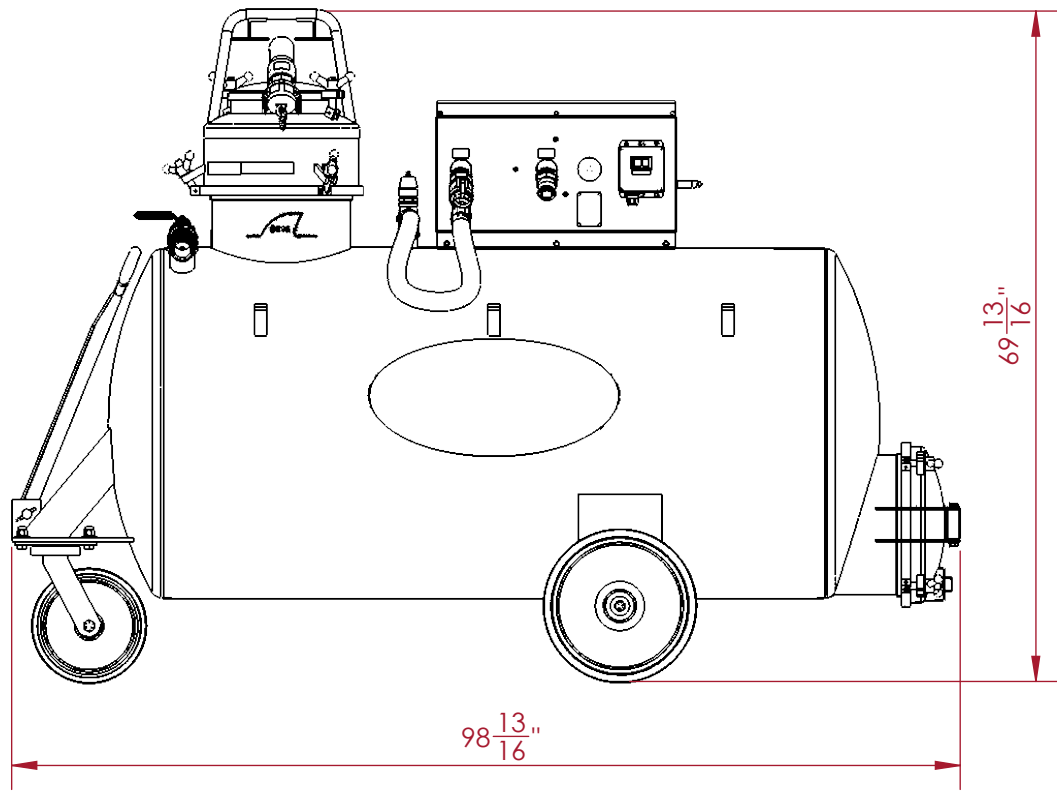

A

A

**CECOR**\* 1000 Jamse Ave.  
 Belleville, WI 53508  
 Phone: (608) 845-6771  
 Email: cecor@cecor.net

TITLE:  
**SE15-300TW-H-F23  
 STANDARD**

**PROPRIETARY AND  
 CONFIDENTIAL:**  
 THE INFORMATION  
 CONTAINED IN THIS  
 DRAWING IS THE SOLE  
 PROPERTY OF CECOR.  
 ANY REPRODUCTION IN  
 PART OR AS A WHOLE  
 WITHOUT THE WRITTEN  
 PERMISSION OF CECOR  
 IS PROHIBITED.

UNITS: INCHES  
 TOLERANCES:  
 FRAC: ± 1/4"

DRAWN: BY BPU DATE 07/18/24	DWG. NO. ASC0.0271	REV 0
---	-----------------------	----------

CUSTOMER SIGN OFF: \_\_\_\_\_ DATE: \_\_\_\_\_

2

1

2

1

B

B

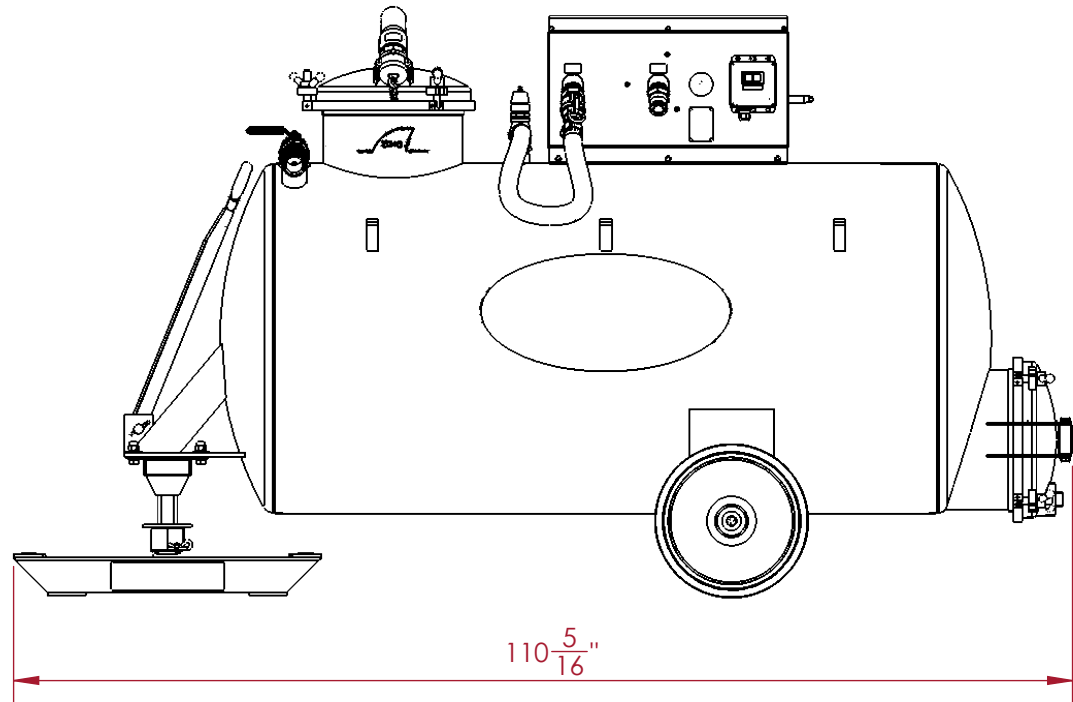
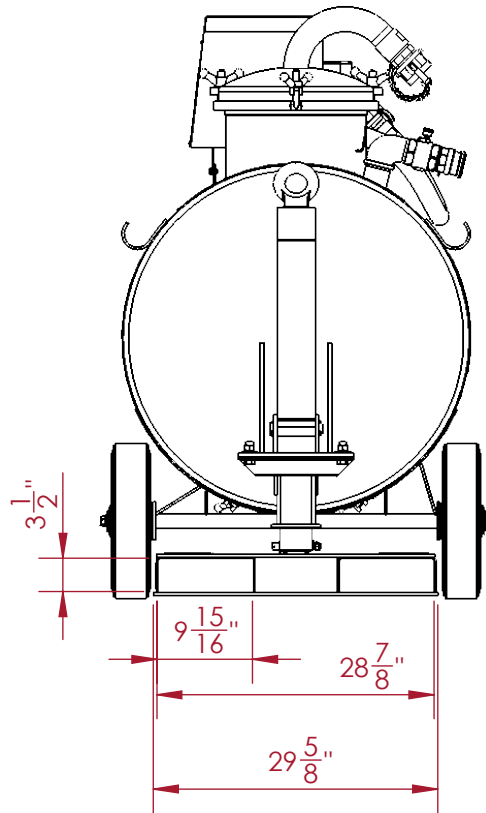

A

A

2

1

CUSTOMER SIGN OFF: \_\_\_\_\_ DATE: \_\_\_\_\_

**PROPRIETARY AND CONFIDENTIAL:**  
 THE INFORMATION CONTAINED IN THIS DRAWING IS THE SOLE PROPERTY OF CECOR. ANY REPRODUCTION IN PART OR AS A WHOLE WITHOUT THE WRITTEN PERMISSION OF CECOR IS PROHIBITED.

UNITS: INCHES  
 TOLERANCES:  
 FRAC: ± 1/4"

**CECOR** 1000 Jamse Ave.  
 Belleville, WI 53508  
 Phone: (608) 845-6771  
 Email: cecor@cecor.net

TITLE:  
**PALLET ATTACHMENT (OPTIONAL)**

DRAWN: BY BPU DATE 07/18/24	DWG. NO. ASC0.0271	REV 0
---	-----------------------	----------