

2

1

B

B

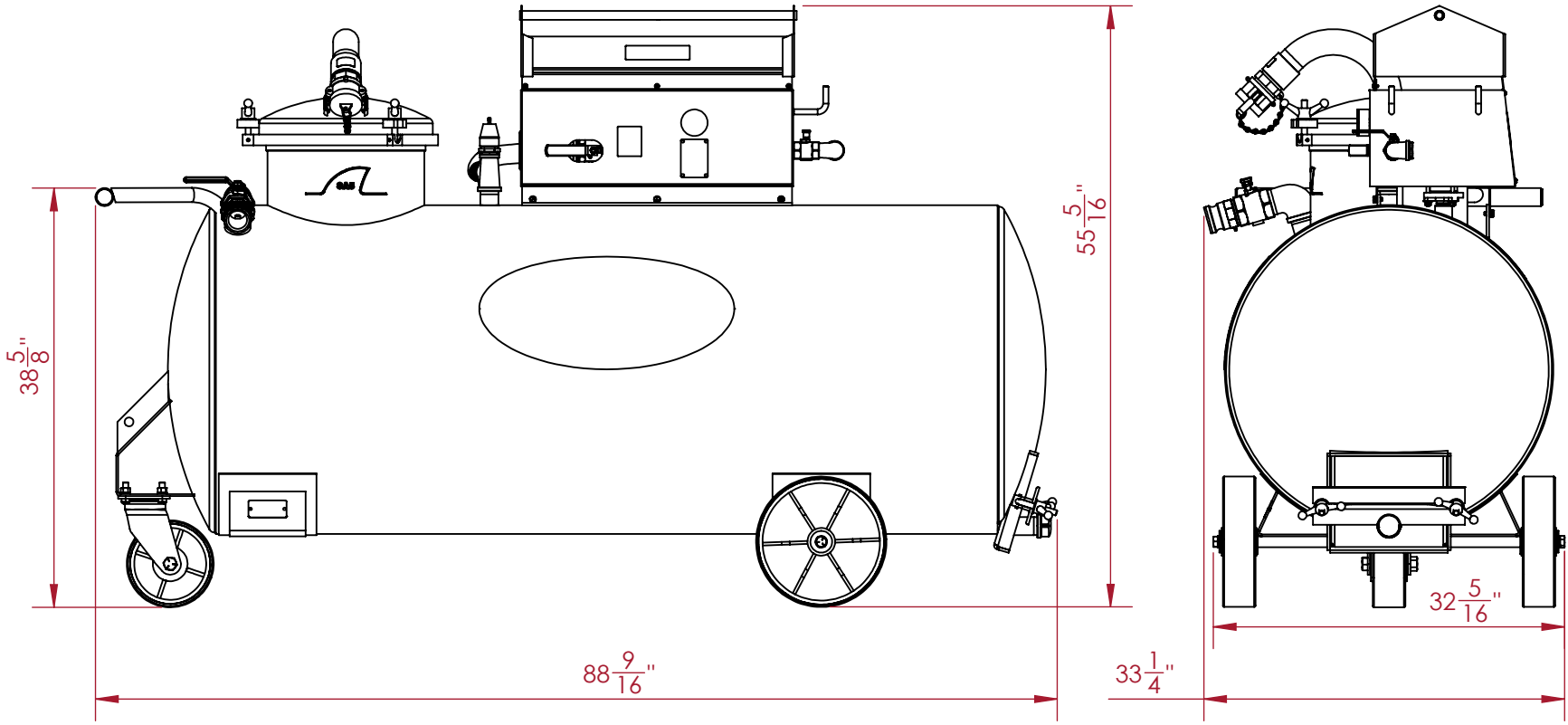

A

A

2

1

CUSTOMER SIGN OFF: _____ DATE: _____

PROPRIETARY AND CONFIDENTIAL:
 THE INFORMATION CONTAINED IN THIS DRAWING IS THE SOLE PROPERTY OF CECOR. ANY REPRODUCTION IN PART OR AS A WHOLE WITHOUT THE WRITTEN PERMISSION OF CECOR IS PROHIBITED.

UNITS: INCHES
 TOLERANCES:
 FRAC: ± 1/4"

CECOR* 1000 Jamse Ave.
 Belleville, WI 53508
 Phone: (608) 845-6771
 Email: cecor@cecor.net

TITLE:
**SA5-200PTL-H-F10
 STANDARD**

DRAWN: BY BPU DATE 07/18/24	DWG. NO. ASC0.0196	REV 0
---	------------------------------	-----------------

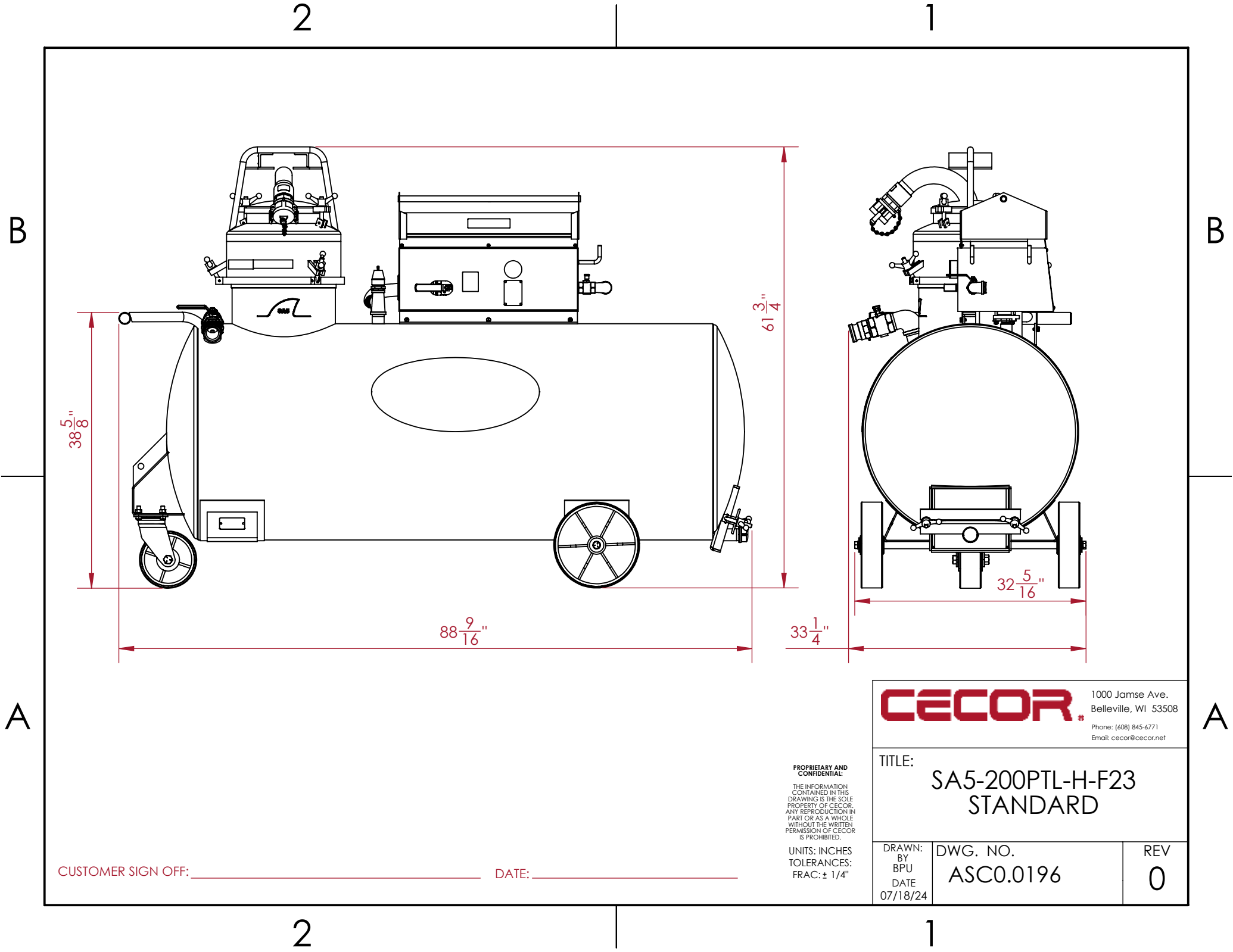

CUSTOMER SIGN OFF: _____ DATE: _____

PROPRIETARY AND CONFIDENTIAL:
 THE INFORMATION CONTAINED IN THIS DRAWING IS THE SOLE PROPERTY OF CECOR. ANY REPRODUCTION IN PART OR AS A WHOLE WITHOUT THE WRITTEN PERMISSION OF CECOR IS PROHIBITED.

UNITS: INCHES
 TOLERANCES:
 FRAC: ± 1/4"

CECOR* 1000 Jamse Ave.
 Belleville, WI 53508
 Phone: (608) 845-6771
 Email: cecor@cecor.net

TITLE:
**SA5-200PTL-H-F23
 STANDARD**

DRAWN: BY BPU DATE 07/18/24	DWG. NO. ASC0.0196	REV 0
---	------------------------------	-----------------

2

1

B

B

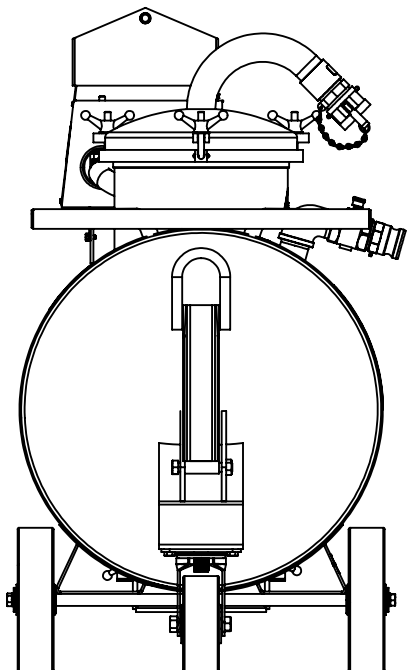

TOW BAR

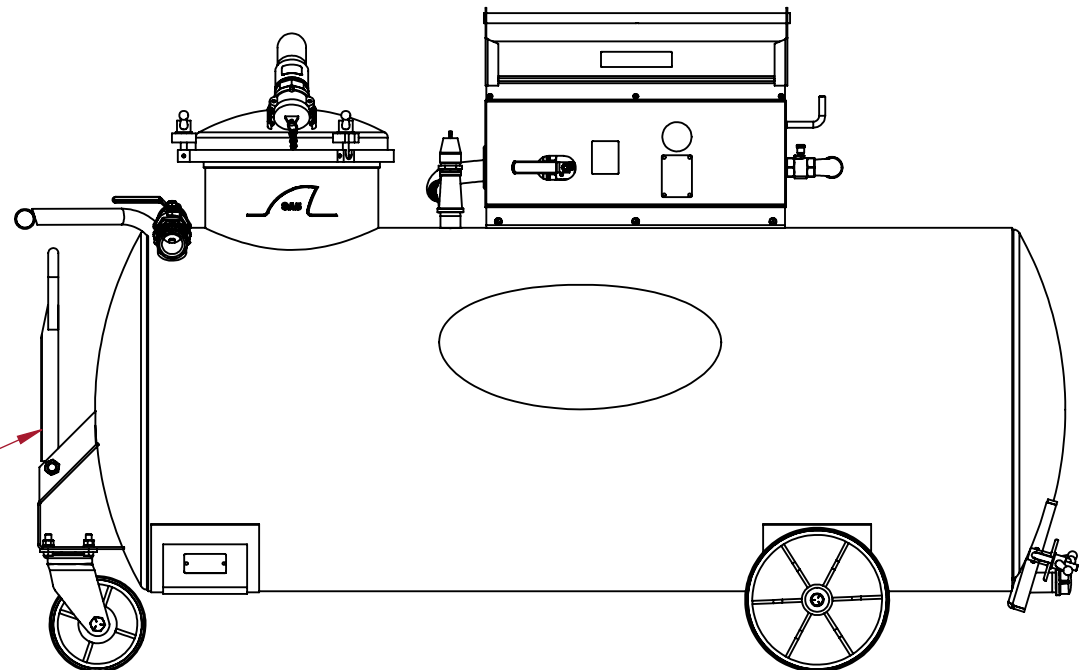

A

A

CECOR* 1000 Jamse Ave.
 Belleville, WI 53508
 Phone: (608) 845-6771
 Email: cecor@cecor.net

TITLE:
**TOW BAR ADD-ON
 (OPTIONAL)**

**PROPRIETARY AND
 CONFIDENTIAL:**
 THE INFORMATION
 CONTAINED IN THIS
 DRAWING IS THE SOLE
 PROPERTY OF CECOR.
 ANY REPRODUCTION IN
 PART OR AS A WHOLE
 WITHOUT THE WRITTEN
 PERMISSION OF CECOR
 IS PROHIBITED.

UNITS: INCHES
 TOLERANCES:
 FRAC: ± 1/4"

DRAWN:
 BY
 BPU
 DATE
 07/18/24

DWG. NO.
 ASC0.0196

REV
 0

CUSTOMER SIGN OFF: _____ DATE: _____

2

1

2

1

B

B

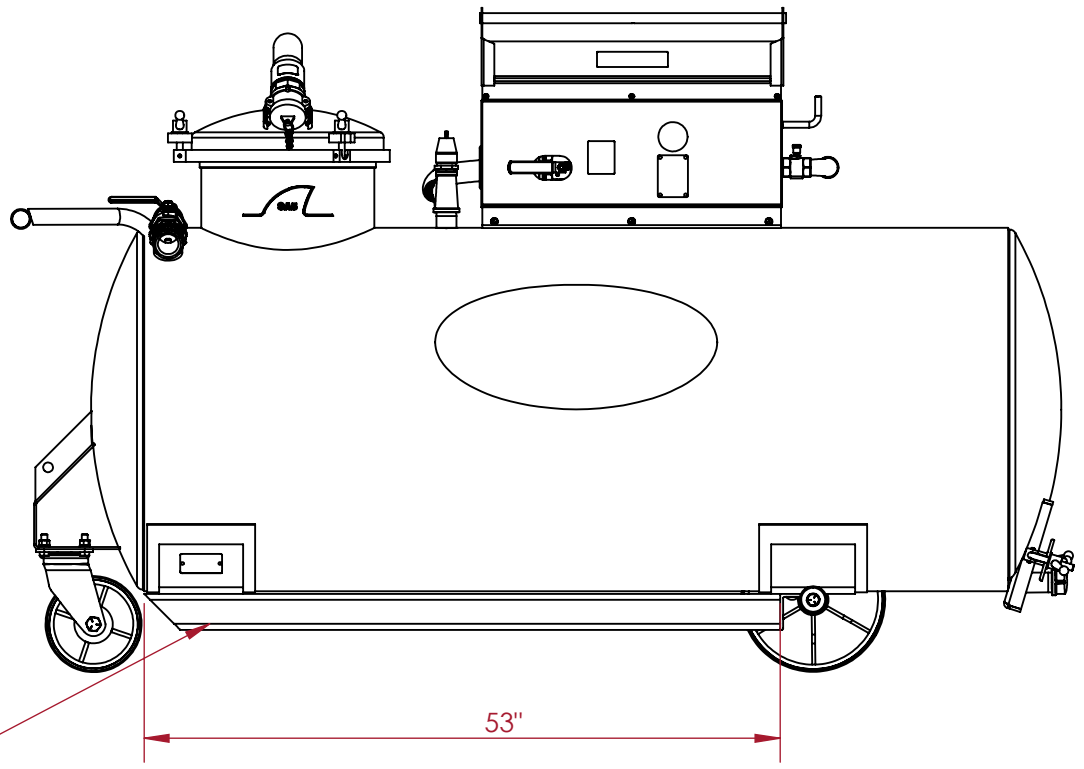
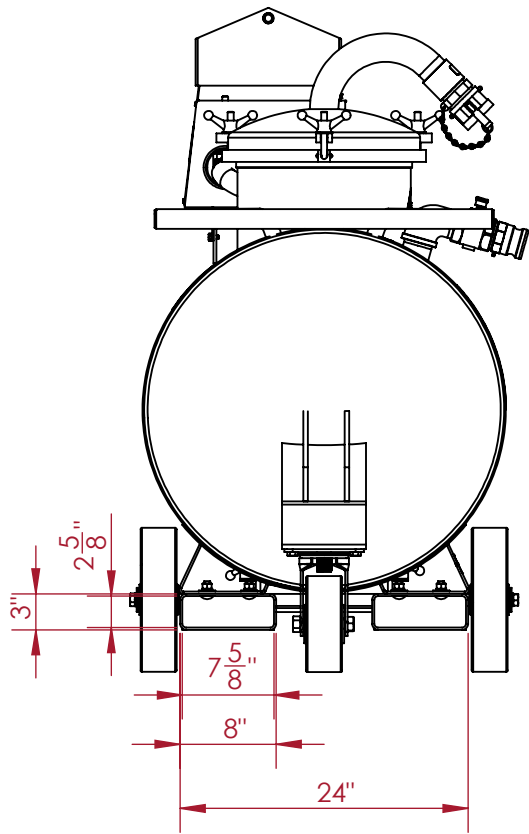

A

A

CUSTOMER SIGN OFF: _____ DATE: _____

PROPRIETARY AND CONFIDENTIAL:
 THE INFORMATION CONTAINED IN THIS DRAWING IS THE SOLE PROPERTY OF CECOR. ANY REPRODUCTION IN PART OR AS A WHOLE WITHOUT THE WRITTEN PERMISSION OF CECOR IS PROHIBITED.

UNITS: INCHES
 TOLERANCES:
 FRAC: ± 1/4"

CECOR* 1000 Jamse Ave.
 Belleville, WI 53508
 Phone: (608) 845-6771
 Email: cecor@cecor.net

TITLE:
**FORK POCKET ADD-ON
 (OPTIONAL)**

DRAWN: BY BPU DATE 07/18/24	DWG. NO. ASC0.0196	REV 0
---	-----------------------	----------

2

1

2

1

B

B

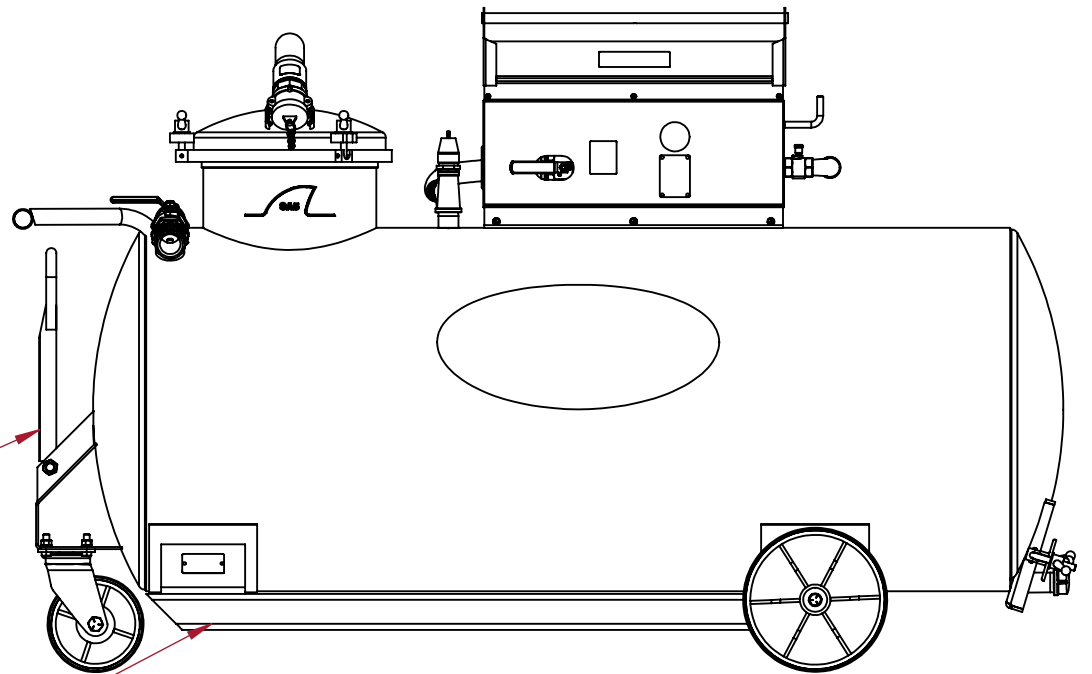
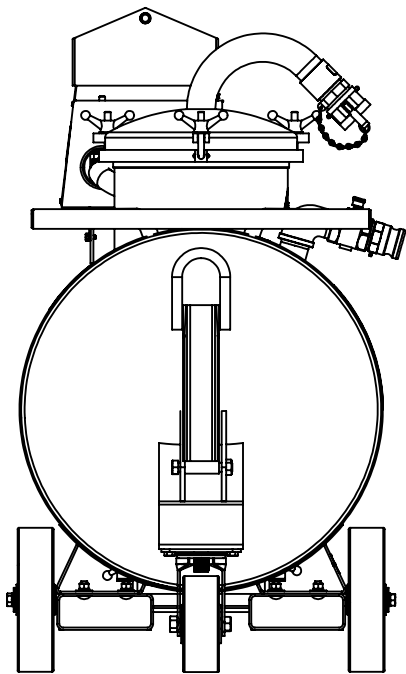

TOW BAR

FORK POCKETS

A

A

CECOR* 1000 Jamse Ave.
 Belleville, WI 53508
 Phone: (608) 845-6771
 Email: cecor@cecor.net

**PROPRIETARY AND
 CONFIDENTIAL:**
 THE INFORMATION
 CONTAINED IN THIS
 DRAWING IS THE SOLE
 PROPERTY OF CECOR.
 ANY REPRODUCTION IN
 PART OR AS A WHOLE
 WITHOUT THE WRITTEN
 PERMISSION OF CECOR
 IS PROHIBITED.

UNITS: INCHES
 TOLERANCES:
 FRAC: ± 1/4"

TITLE:
**FORK POCKETS & TOW
 BAR ADD-ON (OPTIONAL)**

DRAWN:
 BY
 BPU
 DATE
 07/18/24

DWG. NO.
ASC0.0196

REV
0

CUSTOMER SIGN OFF: _____ DATE: _____

2

1

2

1

B

B

A

A

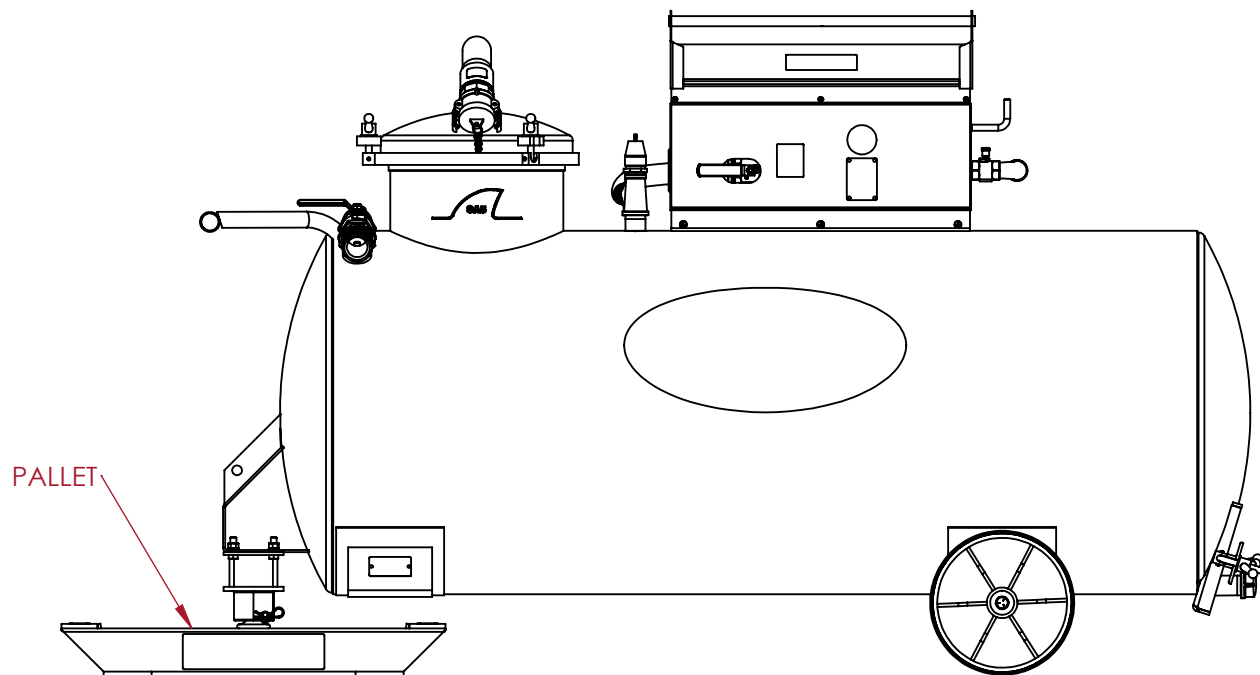
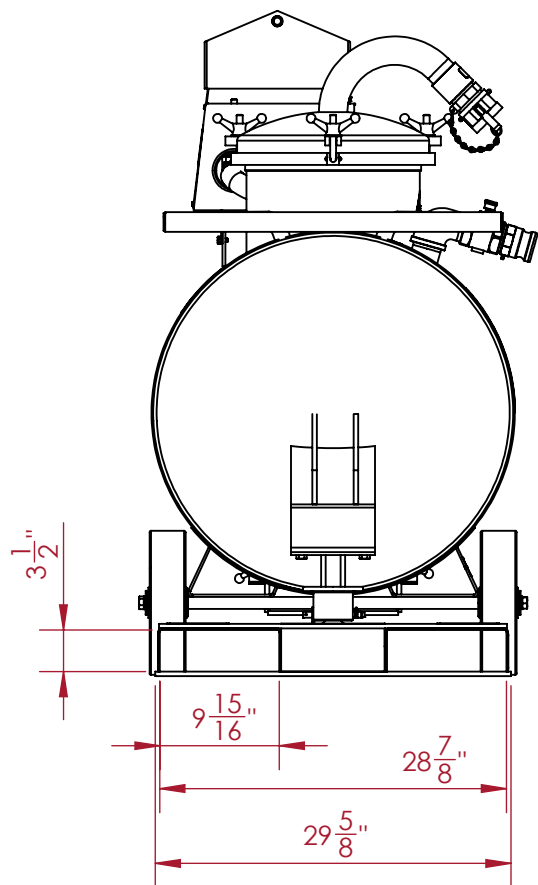

CUSTOMER SIGN OFF: _____ DATE: _____

PROPRIETARY AND CONFIDENTIAL:
 THE INFORMATION CONTAINED IN THIS DRAWING IS THE SOLE PROPERTY OF CECOR. ANY REPRODUCTION IN PART OR AS A WHOLE WITHOUT THE WRITTEN PERMISSION OF CECOR IS PROHIBITED.

UNITS: INCHES
 TOLERANCES:
 FRAC: ± 1/4"

CECOR* 1000 Jamse Ave.
 Belleville, WI 53508
 Phone: (608) 845-6771
 Email: cecor@cecor.net

TITLE:
**PALLET ATTACHMENT
 (OPTIONAL)**

DRAWN: BY BPU DATE 07/18/24	DWG. NO. ASC0.0196	REV 0
---	-----------------------	----------

2

1