

2

1

B

B

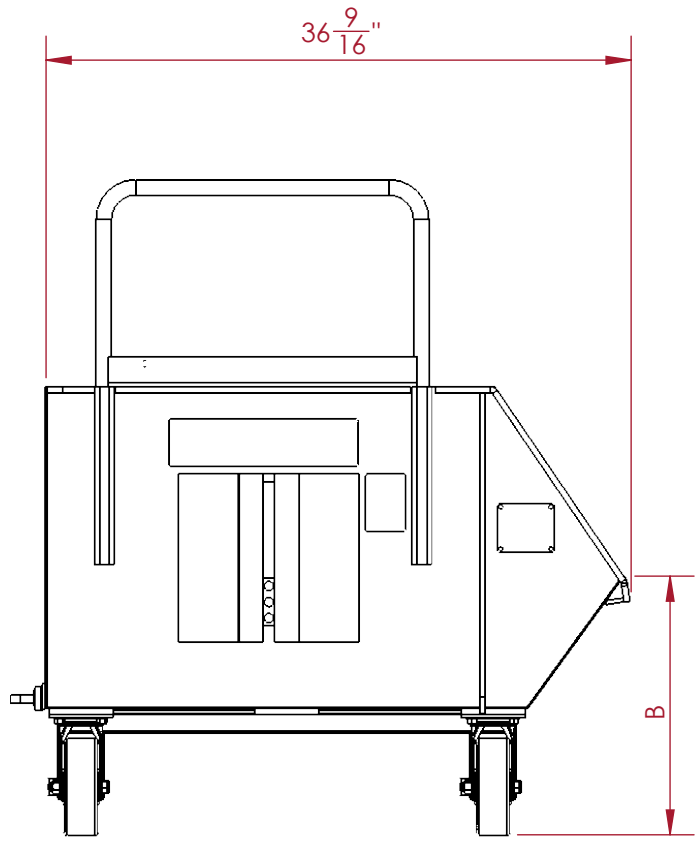
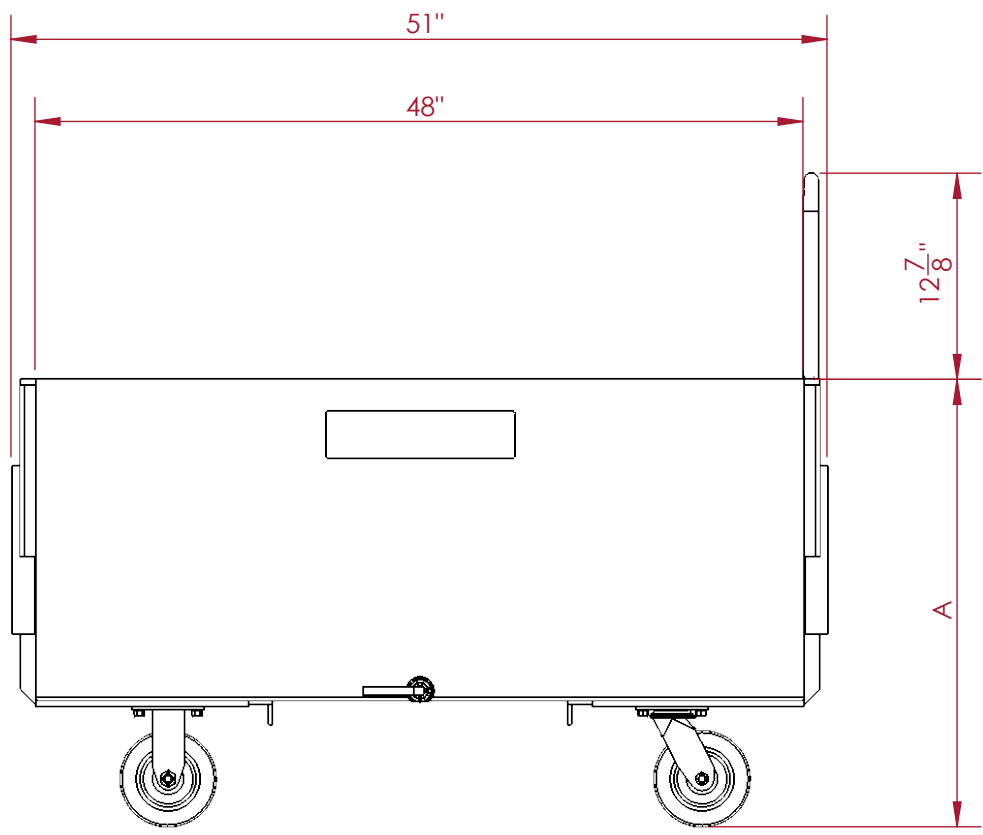

A

A

CASTER SIZE	CART HEIGHT "A"	LIP HEIGHT "B"
3"	24 ³ / ₄ "	13"
4"	26 ¹ / ₈ "	14 ³ / ₈ "
5"	27"	15 ¹ / ₄ "
6"	28"	16 ¹ / ₄ "
8"	30"	18 ¹ / ₄ "

CECOR* 1000 Jamse Ave.
 Belleville, WI 53508
 Phone: (608) 845-6771
 Email: cecor@cecor.net

TITLE: **X54 SALES DWG
 STANDARD**

**PROPRIETARY AND
 CONFIDENTIAL:**
 THE INFORMATION
 CONTAINED IN THIS
 DRAWING IS THE SOLE
 PROPERTY OF CECOR.
 ANY REPRODUCTION IN
 PART OR AS A WHOLE
 WITHOUT THE WRITTEN
 PERMISSION OF CECOR
 IS PROHIBITED.

UNITS: INCHES
 TOLERANCES:
 FRAC: ± 1/32"
 DEC: ±0.03

DRAWN: BY BPU DATE 04/26/24	DWG. NO. ACT0.0157	REV 0
---	------------------------------	-----------------

CUSTOMER SIGN OFF: _____ DATE: _____

2

1

2

1

B

B

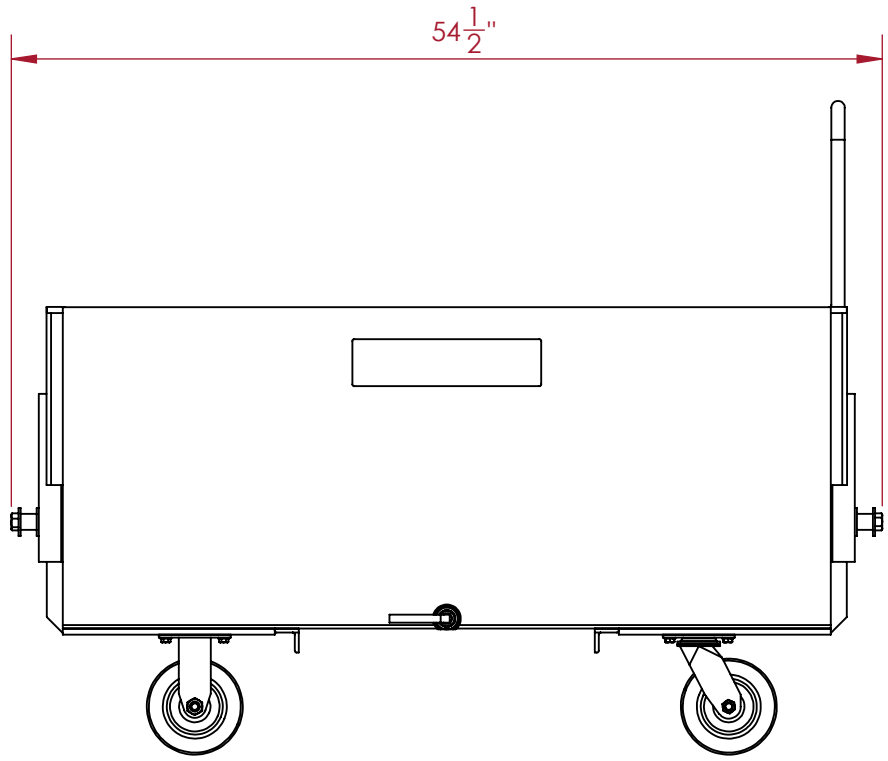

TRUNNION HARDWARE

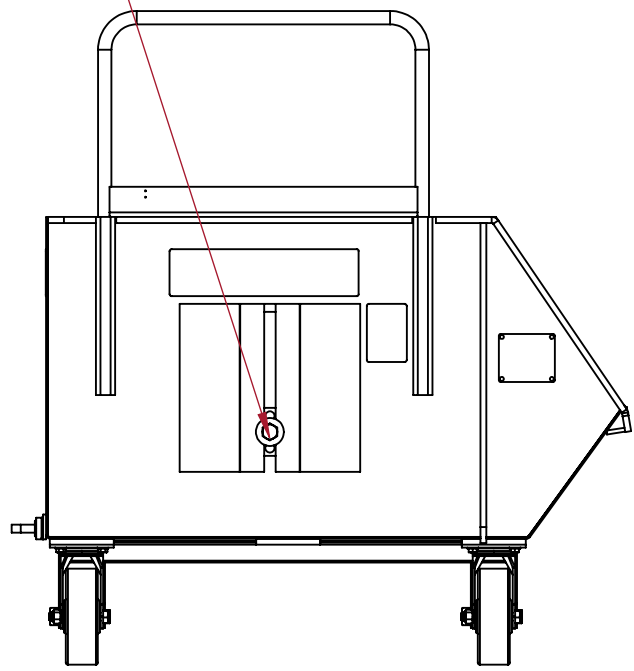

WORKS WITH DF-1054 DUMPING FRAME

A

A

CECOR* 1000 Jamse Ave.
 Belleville, WI 53508
 Phone: (608) 845-6771
 Email: cecor@cecor.net

PROPRIETARY AND CONFIDENTIAL:
 THE INFORMATION CONTAINED IN THIS DRAWING IS THE SOLE PROPERTY OF CECOR. ANY REPRODUCTION IN PART OR AS A WHOLE WITHOUT THE WRITTEN PERMISSION OF CECOR IS PROHIBITED.

TITLE:
**X54 SALES DWG
 OPTIONAL TRUNNION
 HARDWARE**

CUSTOMER SIGN OFF: _____ DATE: _____

UNITS: INCHES
 TOLERANCES:
 FRAC: ± 1/32"
 DEC: ±0.03

DRAWN: BY BPU DATE 04/26/24	DWG. NO. ACT0.0157	REV 0
---	------------------------------	-----------------

2

1

2

1

B

B

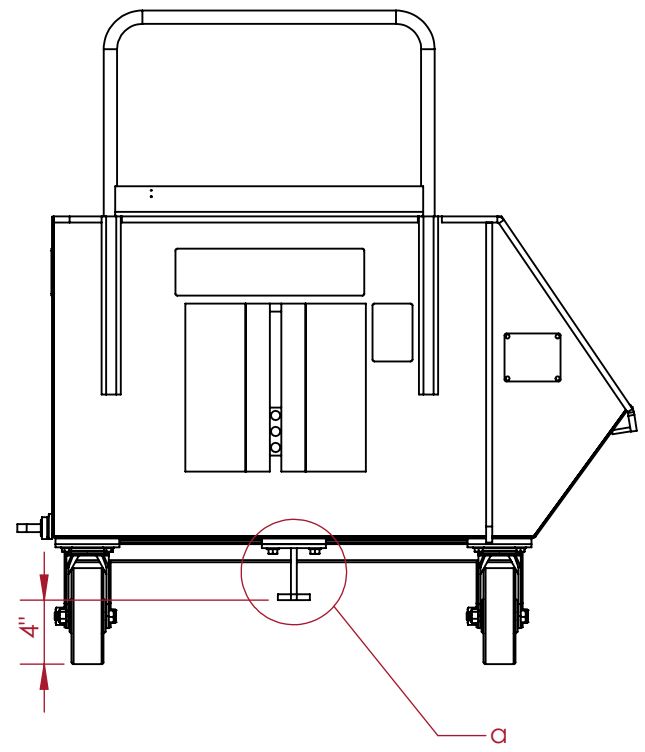
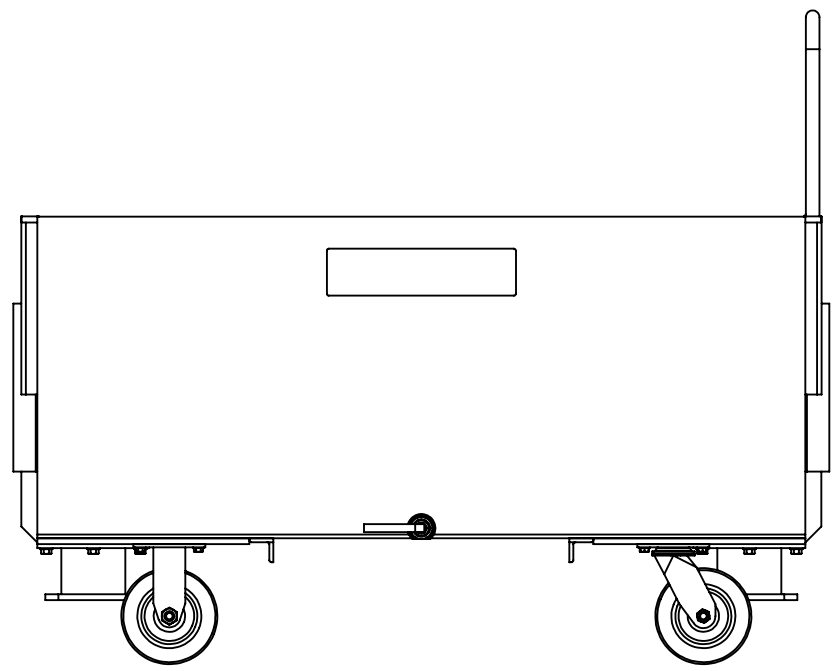

A

A

TEE-RAIL CLEAT PACKAGE IS
DEPENDENT ON THE CASTER SIZE

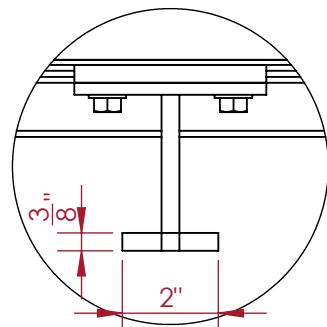

DETAIL a
SCALE 1 : 4

NOTE: TEE-RAIL CLEATS CAN NOT BE
USED WITH CASTERS SMALLER THAN 5".

NOTE: TEE-RAIL CLEATS CAN NOT BE
USED WITH STANDARD FORK POCKETS.

CECOR* 1000 Jamse Ave.
Belleville, WI 53508
Phone: (608) 845-6771
Email: cecor@cecor.net

TITLE:
**X54 SALES DWG
OPTIONAL TEE-RAIL
CLEAT**

**PROPRIETARY AND
CONFIDENTIAL:**
THE INFORMATION
CONTAINED IN THIS
DRAWING IS THE SOLE
PROPERTY OF CECOR.
ANY REPRODUCTION IN
PART OR AS A WHOLE
WITHOUT THE WRITTEN
PERMISSION OF CECOR
IS PROHIBITED.

UNITS: INCHES
TOLERANCES:
FRAC: ± 1/32"
DEC: ±0.03

DRAWN:
BY
BPU
DATE
04/26/24

DWG. NO.
ACT0.0157

REV
0

CUSTOMER SIGN OFF: _____ DATE: _____

2

1

2

1

B

B

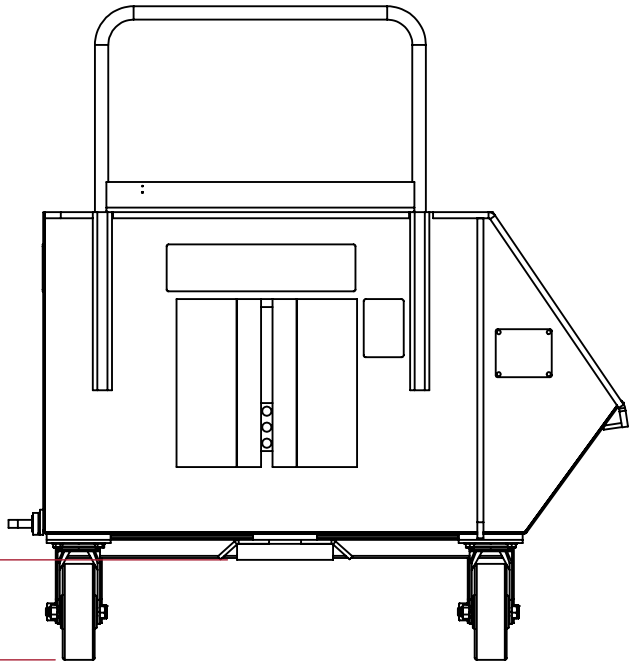
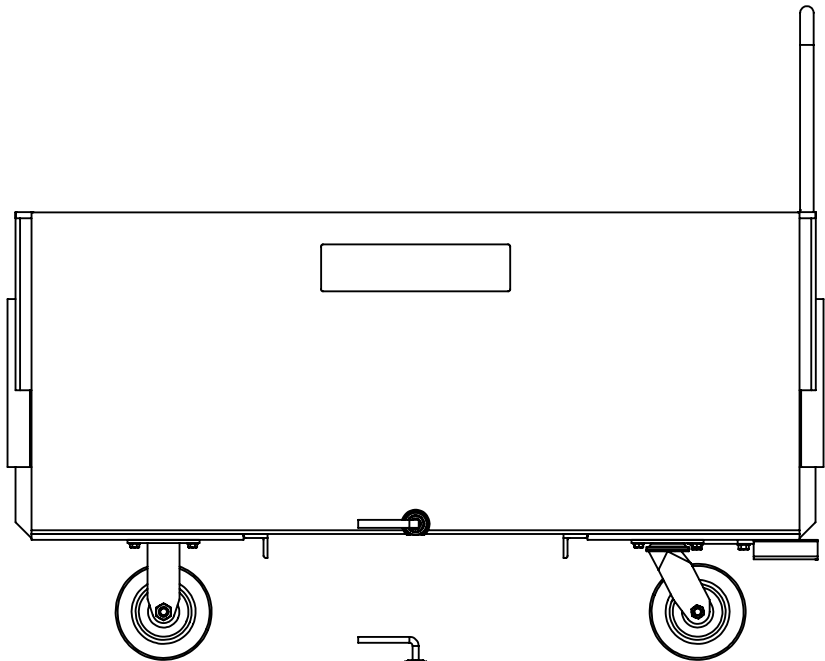

CASTER SIZE	HITCH HEIGHT "C"
3"	3"
4"	4 ³ / ₈ "
5"	5 ¹ / ₄ "
6"	6 ¹ / ₄ "
8"	8 ¹ / ₄ "

ROBOTIC TOWING HITCH

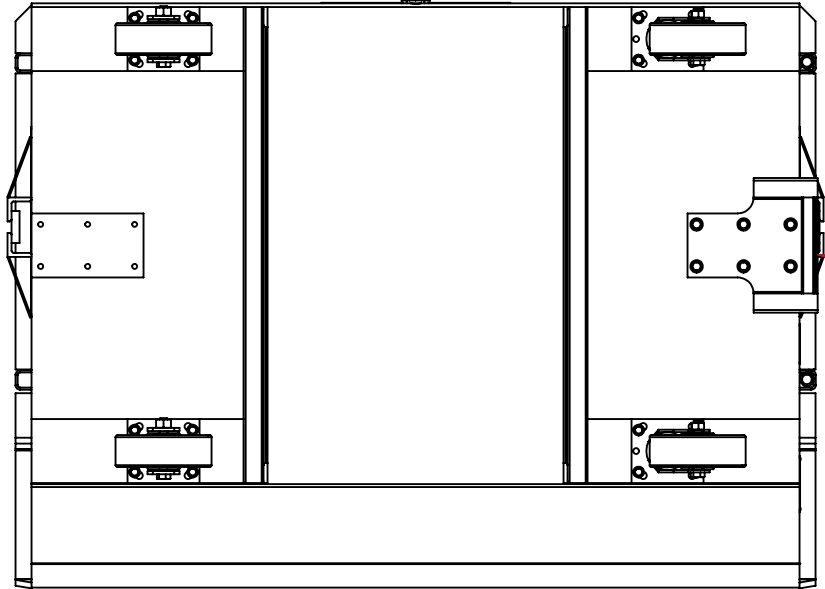

A

A

CECOR* 1000 Jamse Ave.
 Belleville, WI 53508
 Phone: (608) 845-6771
 Email: cecor@cecor.net

TITLE:
**X54 SALES DWG
 OPTIONAL
 ROBOTIC TOWING**

**PROPRIETARY AND
 CONFIDENTIAL:**
 THE INFORMATION
 CONTAINED IN THIS
 DRAWING IS THE SOLE
 PROPERTY OF CECOR.
 ANY REPRODUCTION IN
 PART OR AS A WHOLE
 WITHOUT THE WRITTEN
 PERMISSION OF CECOR
 IS PROHIBITED.

UNITS: INCHES
 TOLERANCES:
 FRAC: ± 1/32"
 DEC: ±0.03

DRAWN: BY BPU DATE 04/26/24	DWG. NO. ACT0.0157	REV 0
---	-----------------------	----------

CUSTOMER SIGN OFF: _____ DATE: _____

2

1

2

1

B

B

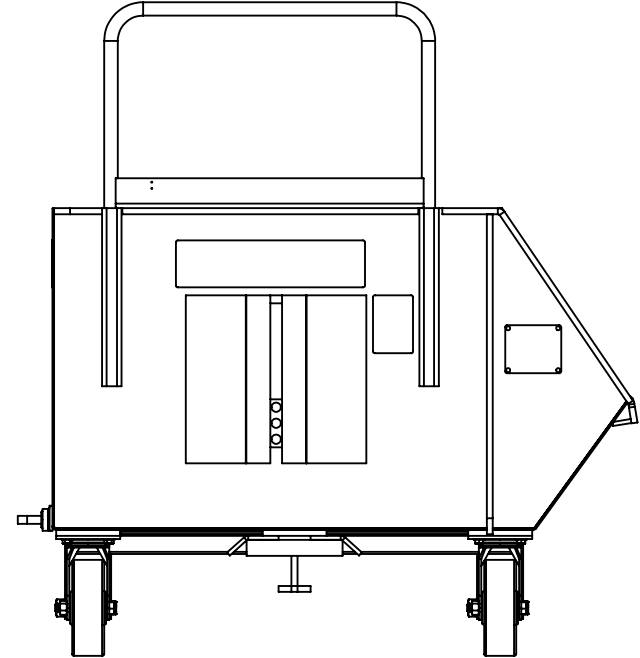
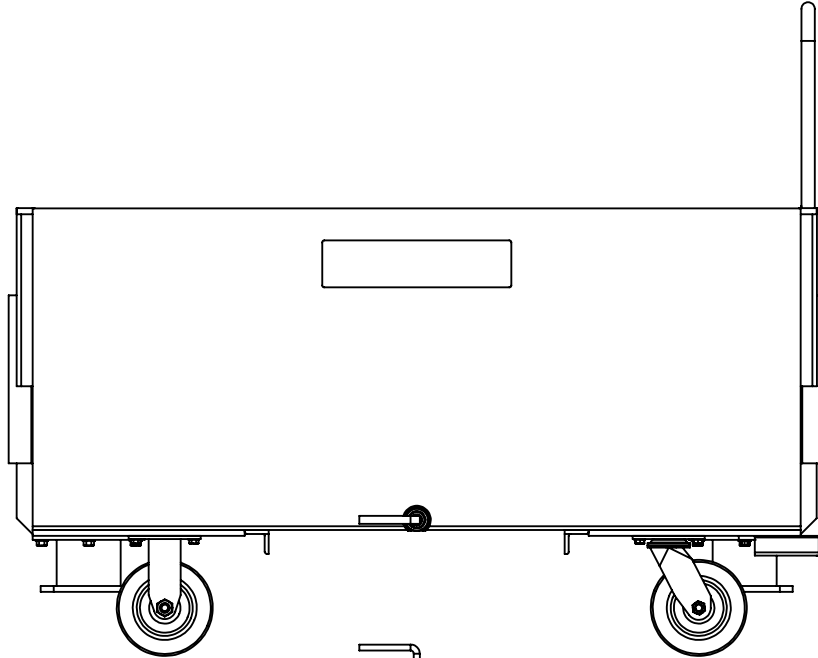

TEE-RAIL CLEAT

ROBOTIC TOWING HITCH

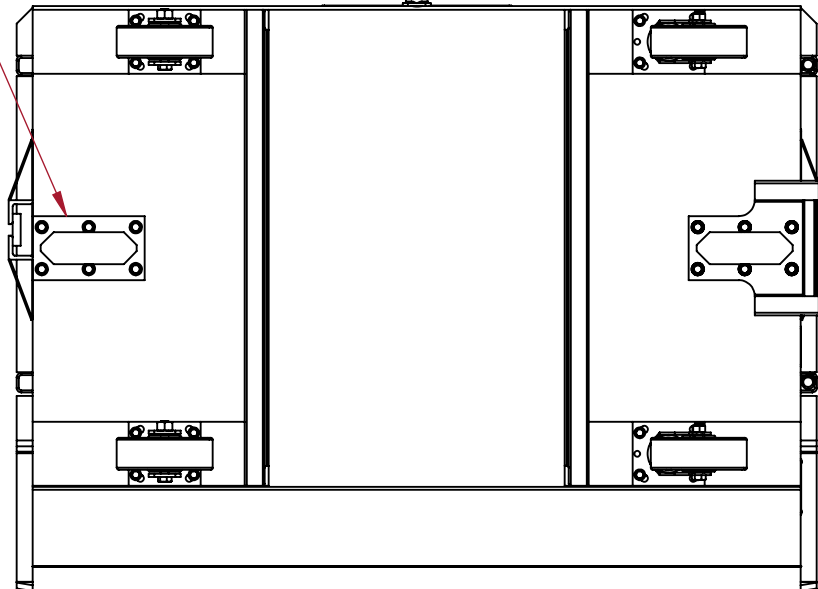

NOTE: TEE-RAIL CLEATS CAN NOT BE USED WITH CASTERS SMALLER THAN 5".

NOTE: TEE-RAIL CLEATS CAN NOT BE USED WITH STANDARD FORK POCKETS.

A

A

CECOR* 1000 Jamse Ave.
 Belleville, WI 53508
 Phone: (608) 845-6771
 Email: cecor@cecor.net

PROPRIETARY AND CONFIDENTIAL:
 THE INFORMATION CONTAINED IN THIS DRAWING IS THE SOLE PROPERTY OF CECOR. ANY REPRODUCTION IN PART OR AS A WHOLE WITHOUT THE WRITTEN PERMISSION OF CECOR IS PROHIBITED.

TITLE:
X54 SALES DWG OPTIONAL ROBOTIC TOWING & TEE-RAIL CLEAT

CUSTOMER SIGN OFF: _____ DATE: _____

UNITS: INCHES
 TOLERANCES:
 FRAC: ± 1/32"
 DEC: ±0.03

DRAWN:
 BY BPU
 DATE 04/26/24

DWG. NO.
ACT0.0157

REV
0

2

1

2

1

B

B

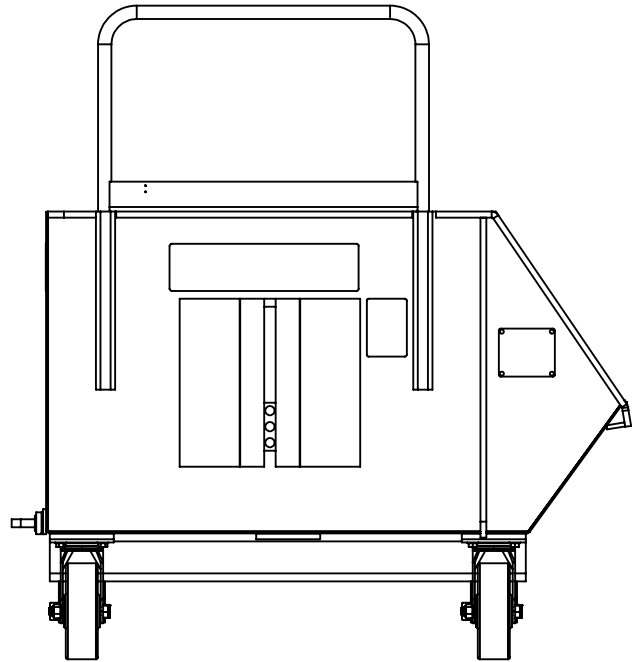
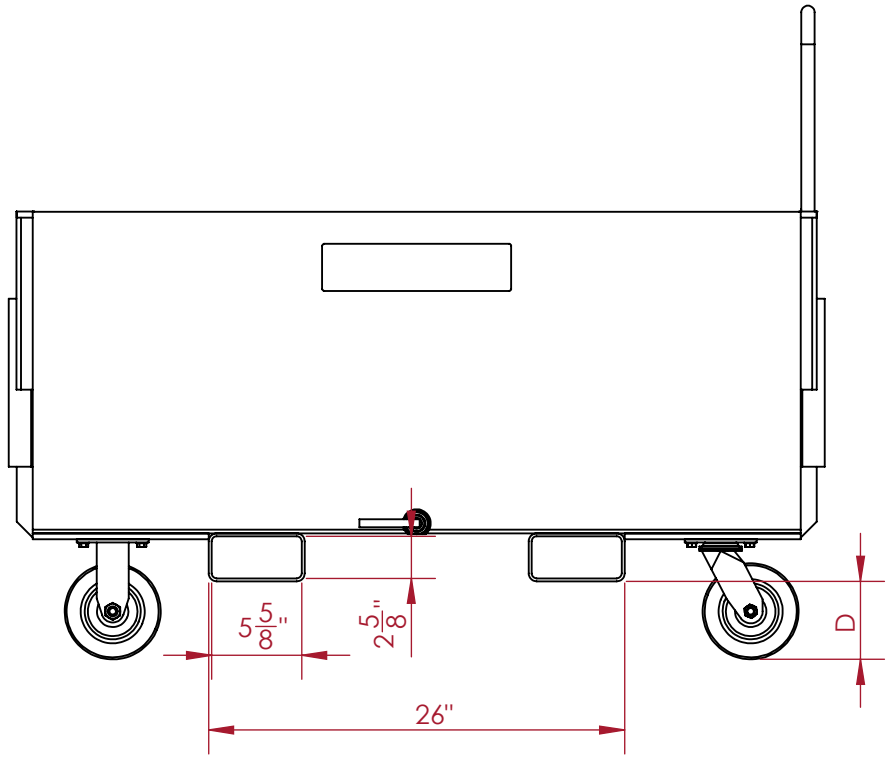

NOTE: FORK POCKETS ARE WELDED ON AND CART MUST BE MADE TO ORDER. TEE-RAIL CLEATS CAN NOT BE USED WITH STANDARD FORK POCKETS.

NOTE: CUSTOM FORK DIMENSIONS ARE AVAILABLE. REQUIRES SPECIAL BUILD.

CASTER SIZE	CART HEIGHT "D"
3"	1 5/8"
4"	3"
5"	3 7/8"
6"	4 7/8"
8"	6 7/8"

PROPRIETARY AND CONFIDENTIAL:
 THE INFORMATION CONTAINED IN THIS DRAWING IS THE SOLE PROPERTY OF CECOR. ANY REPRODUCTION IN PART OR AS A WHOLE WITHOUT THE WRITTEN PERMISSION OF CECOR IS PROHIBITED.

UNITS: INCHES
 TOLERANCES:
 FRAC: ± 1/32"
 DEC: ±0.03

CECOR* 1000 Jamse Ave.
 Belleville, WI 53508
 Phone: (608) 845-6771
 Email: cecor@cecor.net

TITLE:
**X54 SALES DWG
 OPTIONAL FORK
 POCKETS**

DRAWN: BY BPU DATE 04/26/24	DWG. NO. ACT0.0157	REV 0
---	------------------------------	-----------------

CUSTOMER SIGN OFF: _____ DATE: _____

2

1

A

A

2

1

B

B

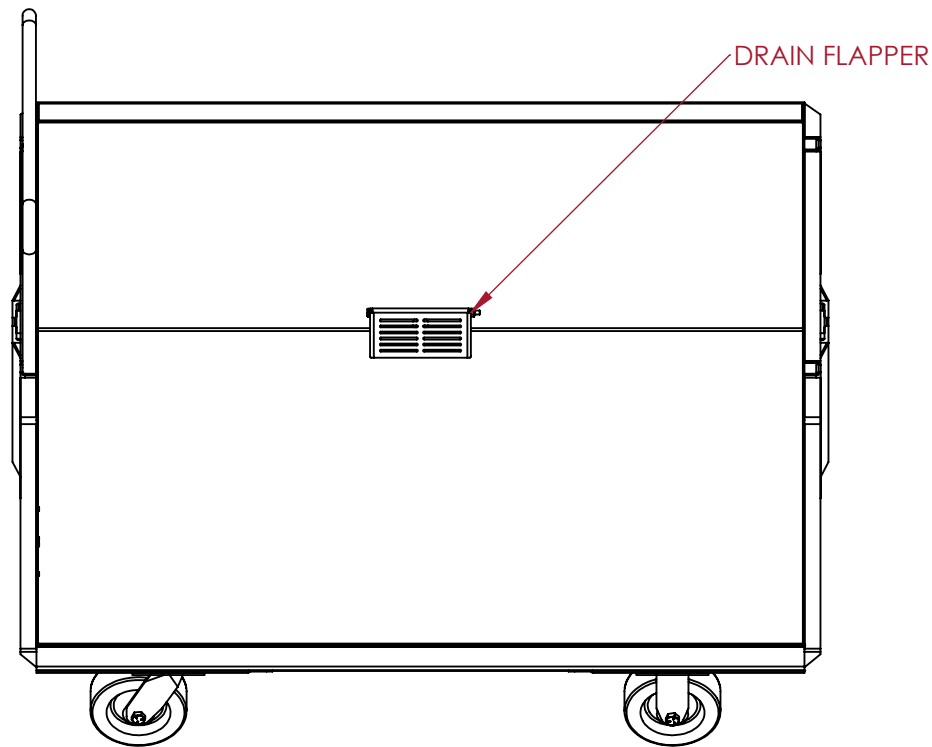

A

A

CECOR* 1000 Jamse Ave.
 Belleville, WI 53508
 Phone: (608) 845-6771
 Email: cecor@cecor.net

**PROPRIETARY AND
 CONFIDENTIAL:**
 THE INFORMATION
 CONTAINED IN THIS
 DRAWING IS THE SOLE
 PROPERTY OF CECOR.
 ANY REPRODUCTION IN
 PART OR AS A WHOLE
 WITHOUT THE WRITTEN
 PERMISSION OF CECOR
 IS PROHIBITED.

UNITS: INCHES
 TOLERANCES:
 FRAC: ± 1/32"
 DEC: ±0.03

TITLE:
**X54 SALES DWG
 OPTIONAL DRAIN
 FLAPPER**

CUSTOMER SIGN OFF: _____ DATE: _____

DRAWN:
 BY
 BPU
 DATE
 04/26/24

DWG. NO.
ACT0.0157

REV
0

2

1