

2

1

B

B

A

A

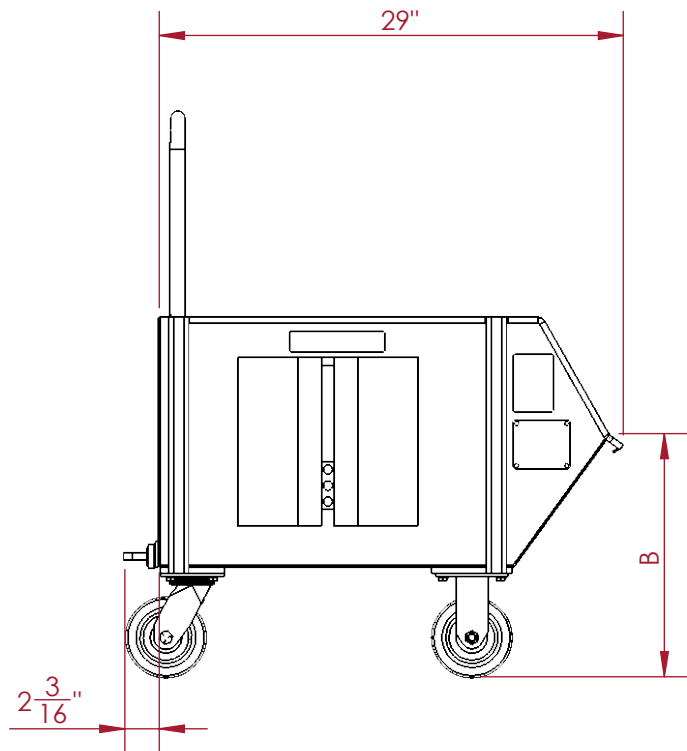
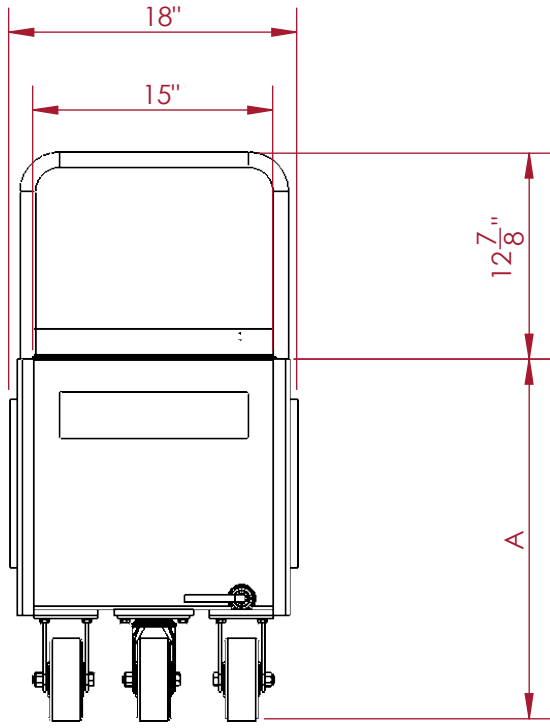

CASTER SIZE	CART HEIGHT "A"	LIP HEIGHT "B"
3"	20 ¹ / ₄ "	12"
4"	21 ⁵ / ₈ "	14 ³ / ₈ "
5"	22 ¹ / ₂ "	15 ¹ / ₄ "
6"	23 ¹ / ₂ "	16 ¹ / ₄ "
8"	25 ¹ / ₂ "	18 ¹ / ₄ "

CECOR* 1000 Jamse Ave.
 Belleville, WI 53508
 Phone: (608) 845-6771
 Email: cecor@cecor.net

TITLE: 042 SALES DWG

PROPRIETARY AND CONFIDENTIAL:
 THE INFORMATION CONTAINED IN THIS DRAWING IS THE SOLE PROPERTY OF CECOR. ANY REPRODUCTION IN PART OR AS A WHOLE WITHOUT THE WRITTEN PERMISSION OF CECOR IS PROHIBITED.

UNITS: INCHES
 TOLERANCES:
 FRAC: ± 1/32"
 DEC: ±0.03

DRAWN: BY BPU DATE 04/26/24	DWG. NO. ACT0.0155	REV 0
---	-----------------------	----------

CUSTOMER SIGN OFF: _____ DATE: _____

2

1

2

1

B

B

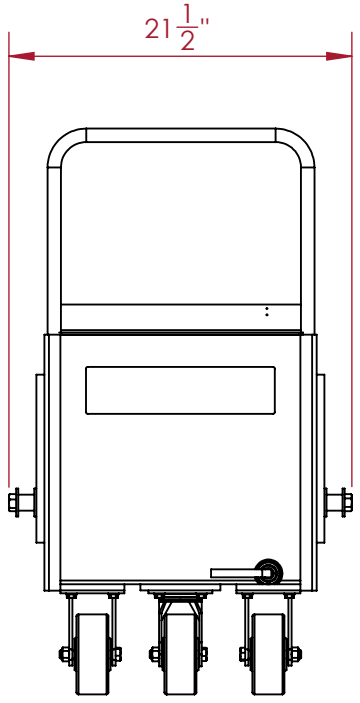

TRUNNION HARDWARE

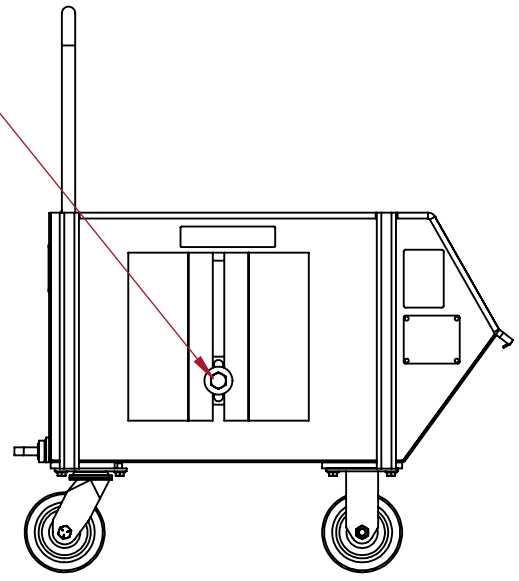

WORKS WITH DF-1042 DUMPING FRAME

A

A

CECOR* 1000 Jamse Ave.
 Belleville, WI 53508
 Phone: (608) 845-6771
 Email: cecor@cecor.net

PROPRIETARY AND CONFIDENTIAL:
 THE INFORMATION CONTAINED IN THIS DRAWING IS THE SOLE PROPERTY OF CECOR. ANY REPRODUCTION IN PART OR AS A WHOLE WITHOUT THE WRITTEN PERMISSION OF CECOR IS PROHIBITED.

TITLE:
**042 SALES DWG
 OPTIONAL TRUNNION
 HARDWARE**

CUSTOMER SIGN OFF: _____ DATE: _____

UNITS: INCHES
 TOLERANCES:
 FRAC: ± 1/32"
 DEC: ±0.03

DRAWN: BY BPU DATE 04/26/24	DWG. NO. ACT0.0155	REV 0
---	-----------------------	----------

2

1

2

1

B

B

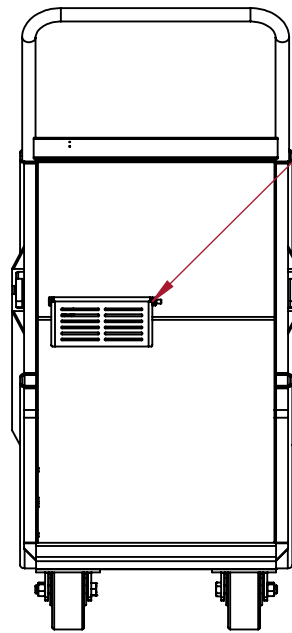

DRAIN FLAPPER

A

A

CECOR* 1000 Jamse Ave.
 Belleville, WI 53508
 Phone: (608) 845-6771
 Email: cecor@cecor.net

PROPRIETARY AND CONFIDENTIAL:
 THE INFORMATION CONTAINED IN THIS DRAWING IS THE SOLE PROPERTY OF CECOR. ANY REPRODUCTION IN PART OR AS A WHOLE WITHOUT THE WRITTEN PERMISSION OF CECOR IS PROHIBITED.

TITLE:
**042 SALES DWG
 OPTIONAL DRAIN
 FLAPPER**

CUSTOMER SIGN OFF: _____ DATE: _____

UNITS: INCHES
 TOLERANCES:
 FRAC: ± 1/32"
 DEC: ±0.03

DRAWN: BY BPU DATE 04/26/24	DWG. NO. ACT0.0155	REV 0
---	-----------------------	----------

2

1