

2

1

B

B

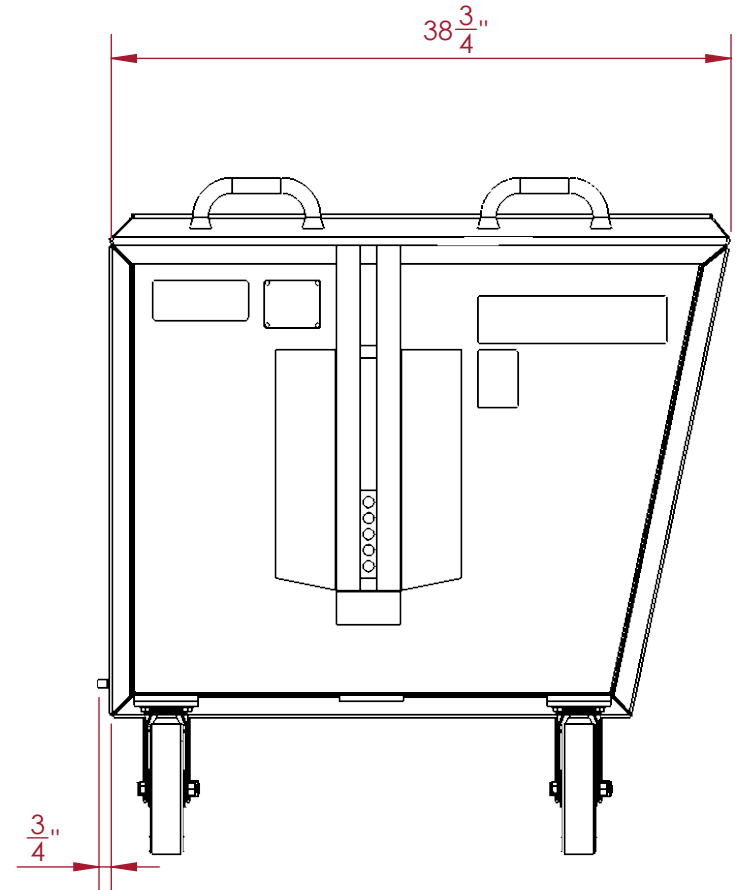
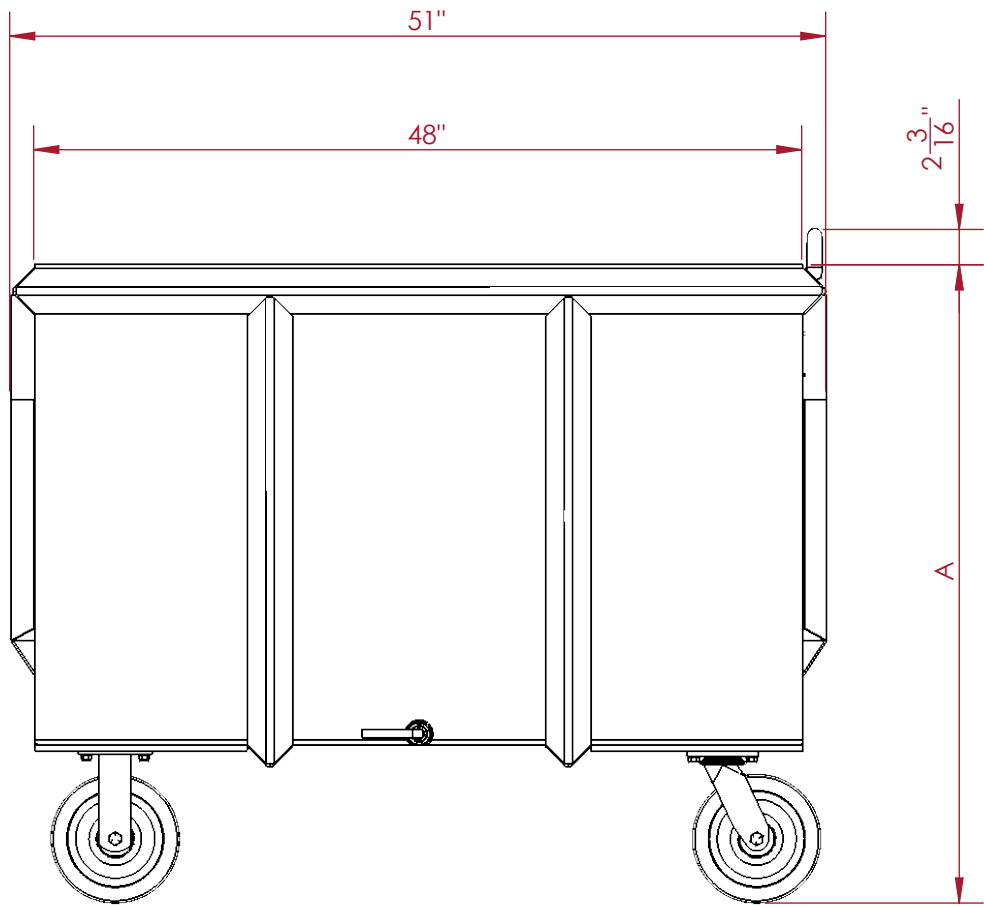

A

A

CASTER SIZE	CART HEIGHT "A"
6"	37 ⁷ / ₈ "
8"	39 ⁷ / ₈ "

CECOR* 1000 Jamse Ave.
 Belleville, WI 53508
 Phone: (608) 845-6771
 Email: cecor@cecor.net

TITLE:
256 SALES DWG

PROPRIETARY AND CONFIDENTIAL:
 THE INFORMATION CONTAINED IN THIS DRAWING IS THE SOLE PROPERTY OF CECOR. ANY REPRODUCTION IN PART OR AS A WHOLE WITHOUT THE WRITTEN PERMISSION OF CECOR IS PROHIBITED.

UNITS: INCHES
 TOLERANCES:
 FRAC: ± 1/32"
 DEC: ±0.03

DRAWN: BY BPU DATE 01/25/24	DWG. NO. ACT0.0075	REV 3
---	------------------------------	-----------------

CUSTOMER SIGN OFF: _____ DATE: _____

2

1

2

1

B

B

55 ⁵/₈"

TRUNNION HARDWARE

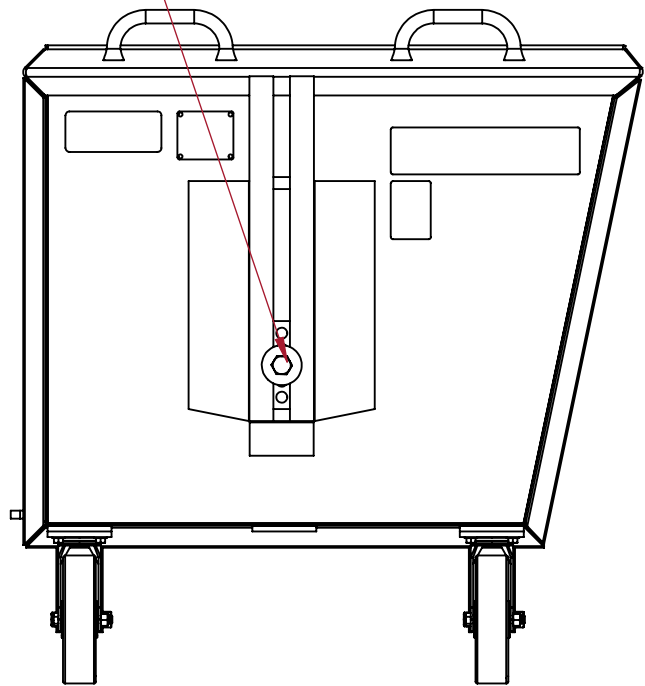
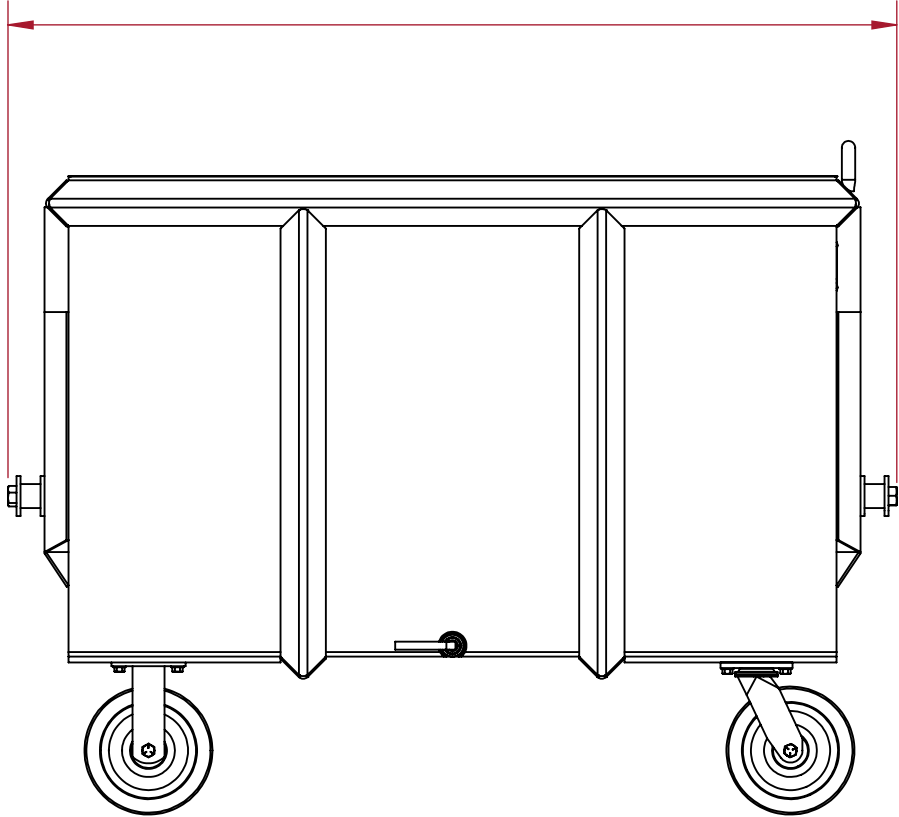

WORKS WITH DF-1054 DUMPING FRAME

A

A

CECOR* 1000 Jamse Ave.
 Belleville, WI 53508
 Phone: (608) 845-6771
 Email: cecor@cecor.net

PROPRIETARY AND CONFIDENTIAL:
 THE INFORMATION CONTAINED IN THIS DRAWING IS THE SOLE PROPERTY OF CECOR. ANY REPRODUCTION IN PART OR AS A WHOLE WITHOUT THE WRITTEN PERMISSION OF CECOR IS PROHIBITED.

TITLE:
**256 SALES DWG
 OPTIONAL TRUNNION
 HARDWARE**

CUSTOMER SIGN OFF: _____ DATE: _____

UNITS: INCHES
 TOLERANCES:
 FRAC: ± 1/32"
 DEC: ±0.03

DRAWN: BY BPU DATE 01/25/24	DWG. NO. ACT0.0075	REV 3
---	------------------------------	-----------------

2

1

2

1

B

B

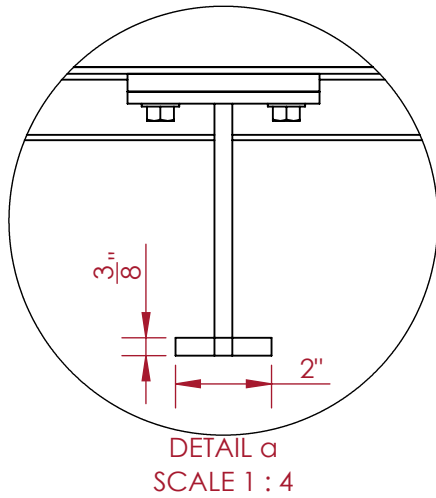
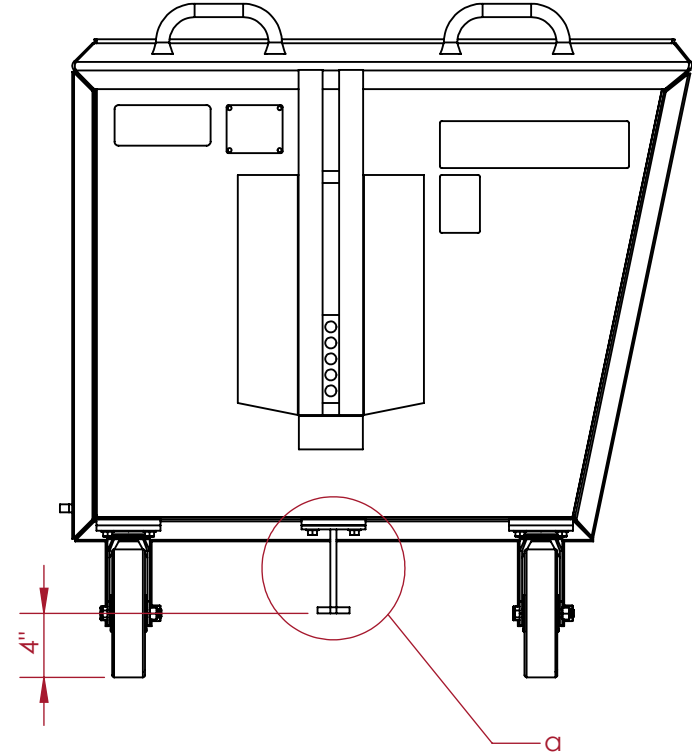
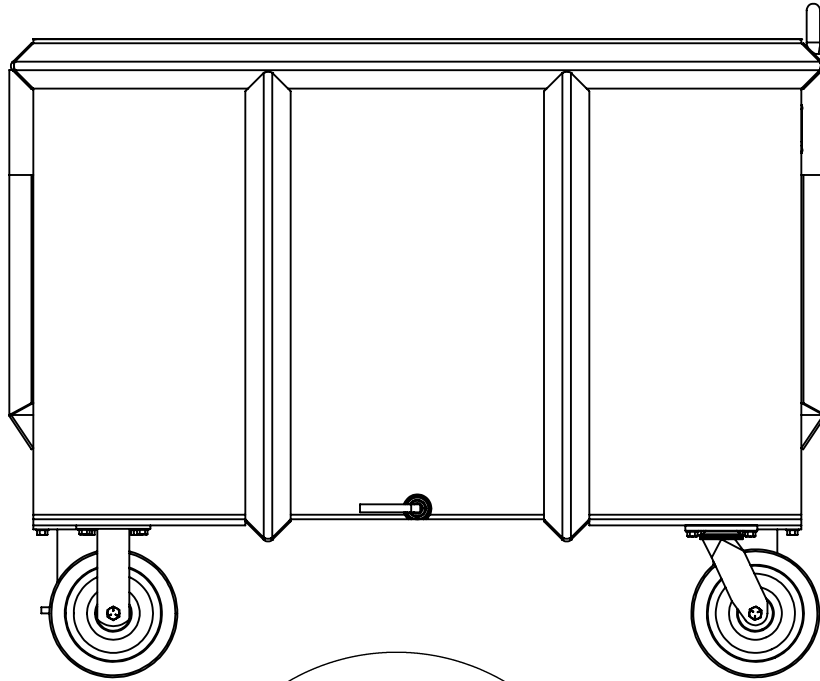

TEE-RAIL CLEAT PACKAGE IS
DEPENDENT ON THE CASTER SIZE

NOTE: TEE-RAIL CLEATS CAN NOT BE
USED WITH STANDARD FORK POCKETS.

CECOR[®] 1000 Jamse Ave.
Belleville, WI 53508
Phone: (608) 845-6771
Email: cecor@cecor.net

TITLE:
**256 SALES DWG
OPTIONAL TEE-RAIL
CLEATS**

**PROPRIETARY AND
CONFIDENTIAL:**
THE INFORMATION
CONTAINED IN THIS
DRAWING IS THE SOLE
PROPERTY OF CECOR.
ANY REPRODUCTION IN
PART OR AS A WHOLE
WITHOUT THE WRITTEN
PERMISSION OF CECOR
IS PROHIBITED.

UNITS: INCHES
TOLERANCES:
FRAC: ± 1/32"
DEC: ±0.03

DRAWN:
BY
BPU
DATE
01/25/24

DWG. NO.
ACT0.0075

REV
3

CUSTOMER SIGN OFF: _____ DATE: _____

2

1

A

A

2

1

B

B

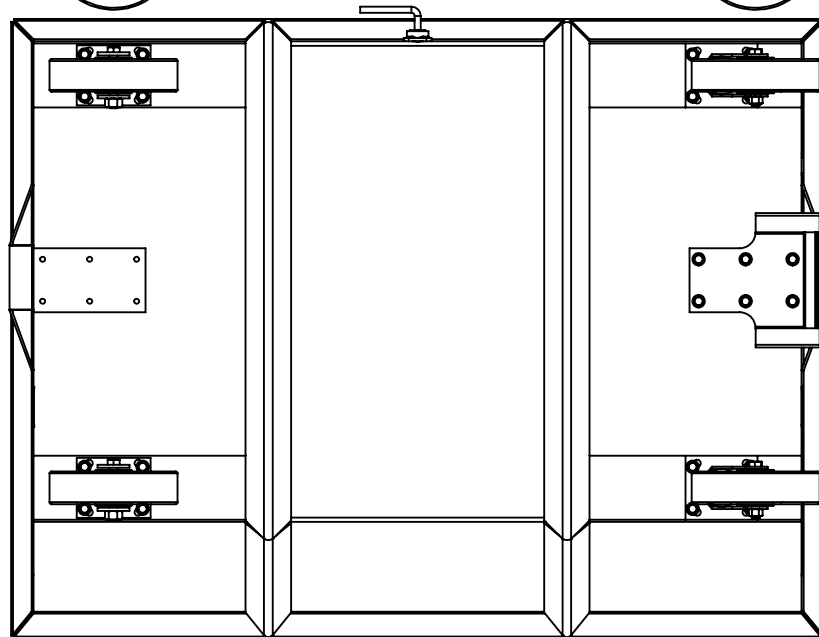
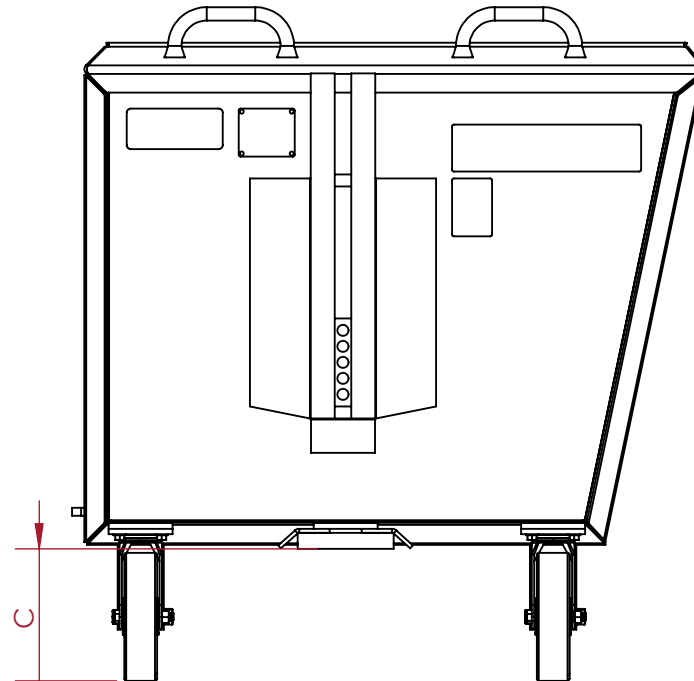
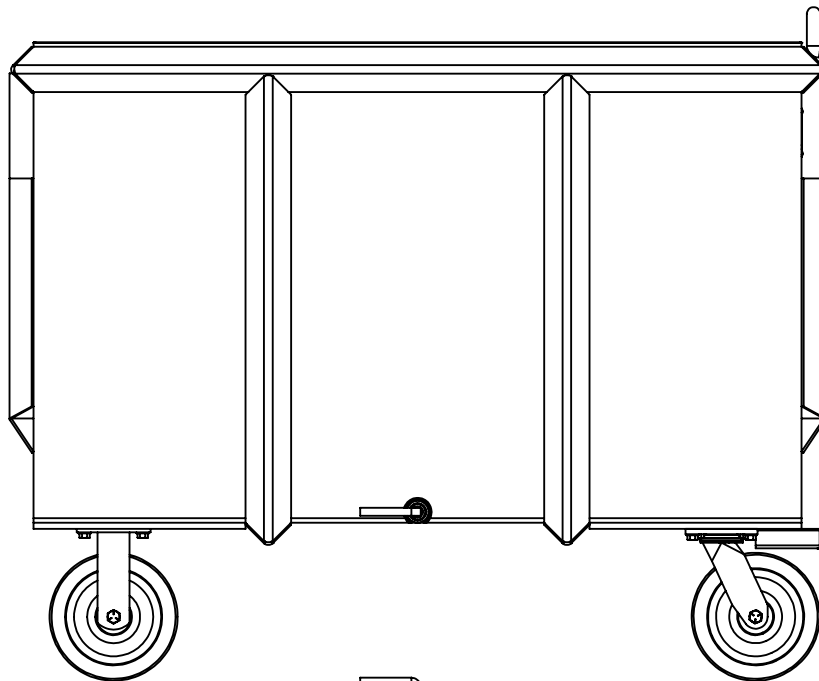

CASTER SIZE	HITCH HEIGHT "C"
6"	6 1/4"
8"	8 1/4"

ROBOTIC TOWING HITCH

A

A

CECOR* 1000 Jamse Ave.
 Belleville, WI 53508
 Phone: (608) 845-6771
 Email: cecor@cecor.net

PROPRIETARY AND
 CONFIDENTIAL:
 THE INFORMATION
 CONTAINED IN THIS
 DRAWING IS THE SOLE
 PROPERTY OF CECOR.
 ANY REPRODUCTION IN
 PART OR AS A WHOLE
 WITHOUT THE WRITTEN
 PERMISSION OF CECOR
 IS PROHIBITED.

UNITS: INCHES
 TOLERANCES:
 FRAC: ± 1/32"
 DEC: ±0.03

TITLE:
**256 SALES DWG
 OPTIONAL
 ROBOTIC TOWING**

DRAWN: BY BPU DATE 01/25/24	DWG. NO. ACT0.0075	REV 3
---	------------------------------	-----------------

CUSTOMER SIGN OFF: _____ DATE: _____

2

1

2

1

B

B

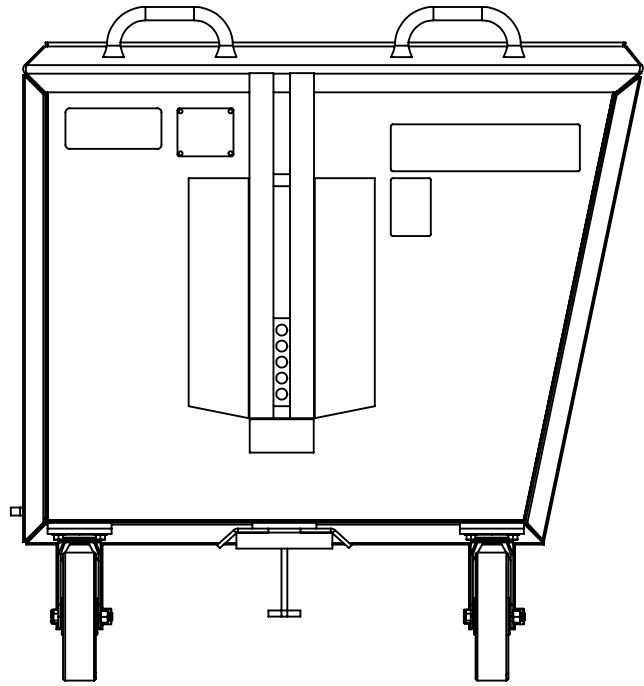
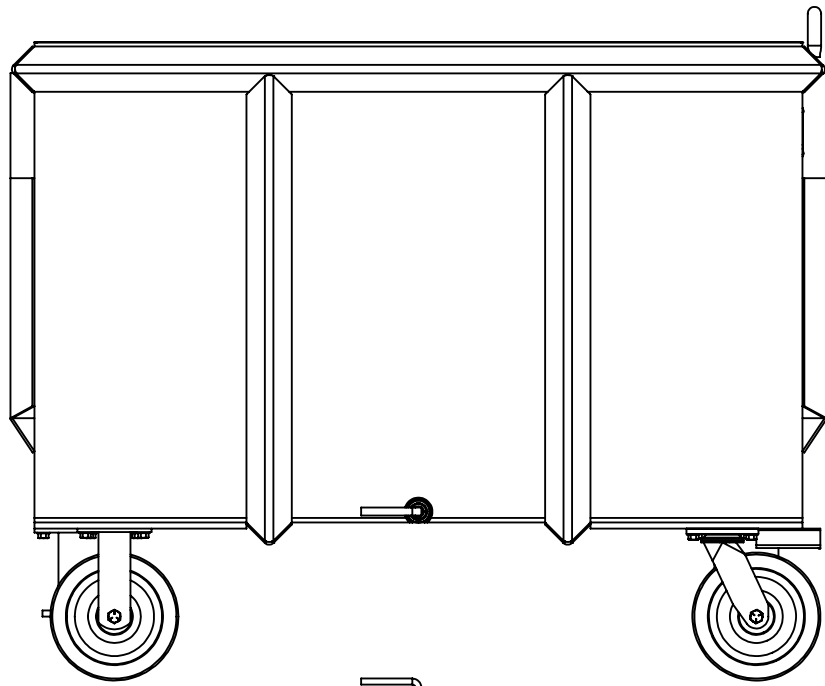

A

A

TEE-RAIL CLEAT

ROBOTIC TOWING HITCH

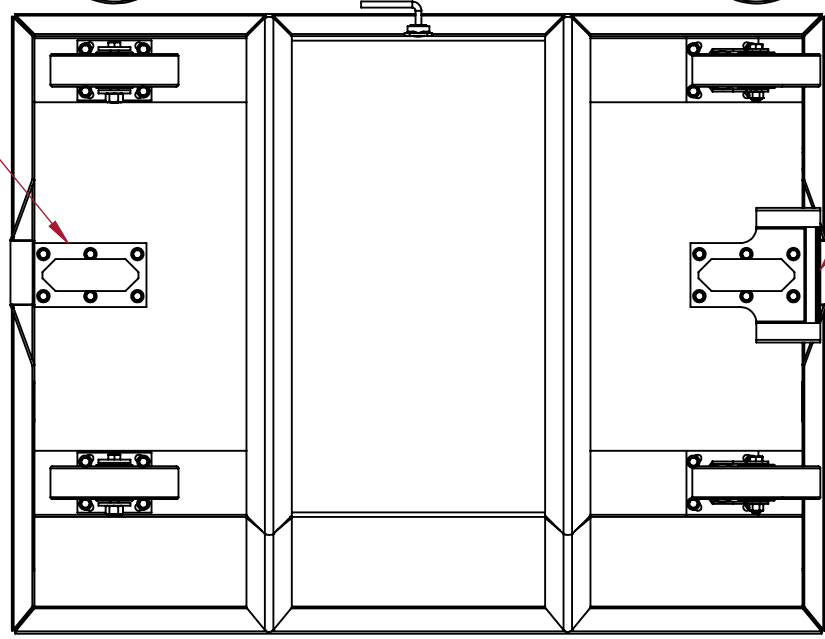

NOTE: TEE-RAIL CLEATS CAN NOT BE USED WITH STANDARD FORK POCKETS.

CECOR*

1000 Jamse Ave.
Belleville, WI 53508
Phone: (608) 845-6771
Email: cecor@cecor.net

PROPRIETARY AND CONFIDENTIAL:
THE INFORMATION CONTAINED IN THIS DRAWING IS THE SOLE PROPERTY OF CECOR. ANY REPRODUCTION IN PART OR AS A WHOLE WITHOUT THE WRITTEN PERMISSION OF CECOR IS PROHIBITED.

TITLE:
256 SALES DWG OPTIONAL
ROBOTIC TOWING & TEE-RAIL CLEAT

CUSTOMER SIGN OFF: _____ DATE: _____

UNITS: INCHES
TOLERANCES:
FRAC: ± 1/32"
DEC: ±0.03

DRAWN:
BY
BPU
DATE
01/25/24

DWG. NO.
ACT0.0075

REV
3

2

1

2

1

B

B

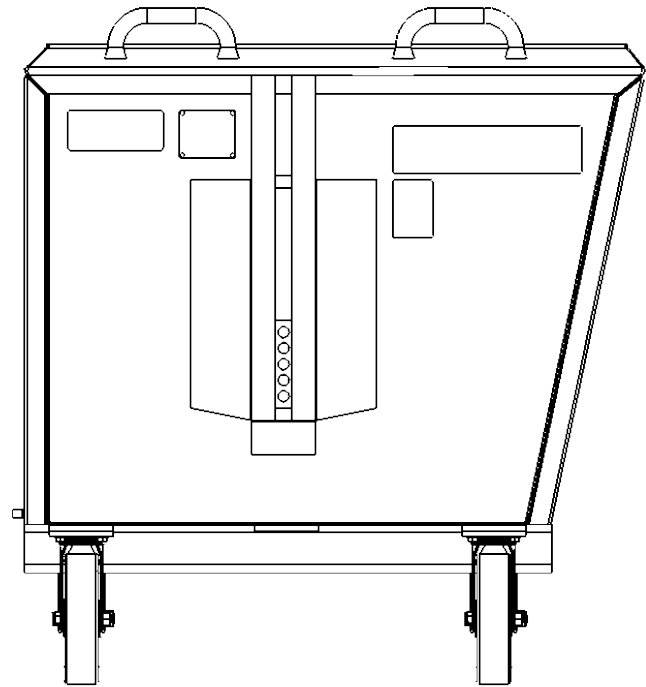
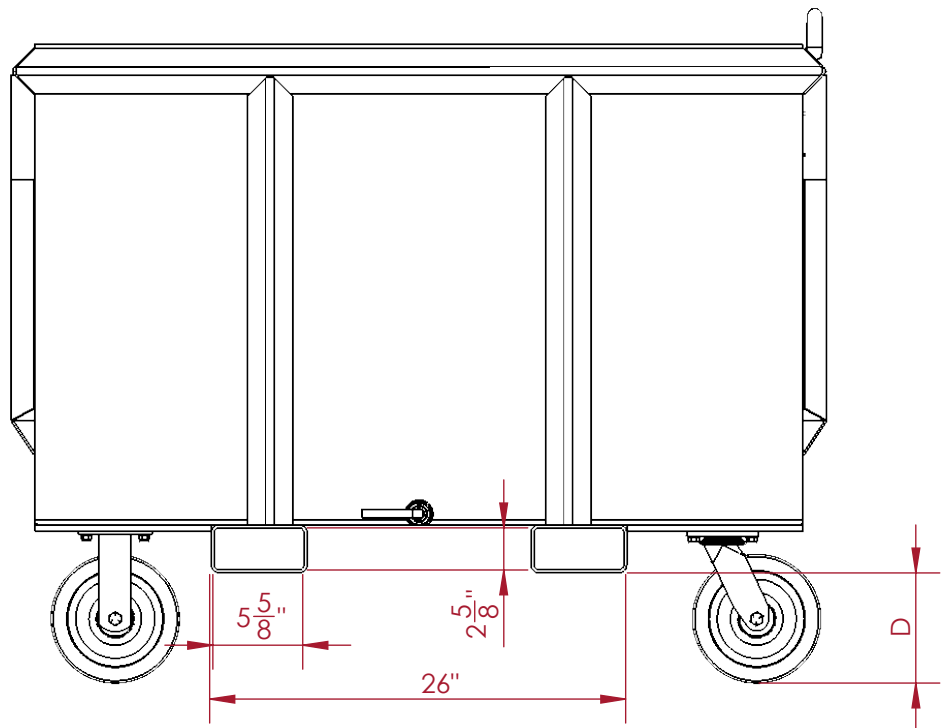

CASTER SIZE	CART HEIGHT "D"
6"	4 7/8"
8"	6 7/8"

NOTE: FORK POCKETS ARE WELDED ON AND CART MUST BE MADE TO ORDER. TEE-RAIL CLEATS CAN NOT BE USED WITH STANDARD FORK POCKETS.

NOTE: CUSTOM FORK DIMENSIONS ARE AVAILABLE. REQUIRES SPECIAL BUILD.

CUSTOMER SIGN OFF: _____ DATE: _____

CECOR* 1000 Jamse Ave.
Belleville, WI 53508
Phone: (608) 845-6771
Email: cecor@cecor.net

TITLE:
256 SALES DWG

PROPRIETARY AND CONFIDENTIAL:
THE INFORMATION CONTAINED IN THIS DRAWING IS THE SOLE PROPERTY OF CECOR. ANY REPRODUCTION IN PART OR AS A WHOLE WITHOUT THE WRITTEN PERMISSION OF CECOR IS PROHIBITED.

UNITS: INCHES
TOLERANCES:
FRAC: ± 1/32"
DEC: ±0.03

DRAWN: BY BPU DATE 01/25/24	DWG. NO. ACT0.0075	REV 3
---	------------------------------	-----------------

2

1

A

A

2

1

B

B

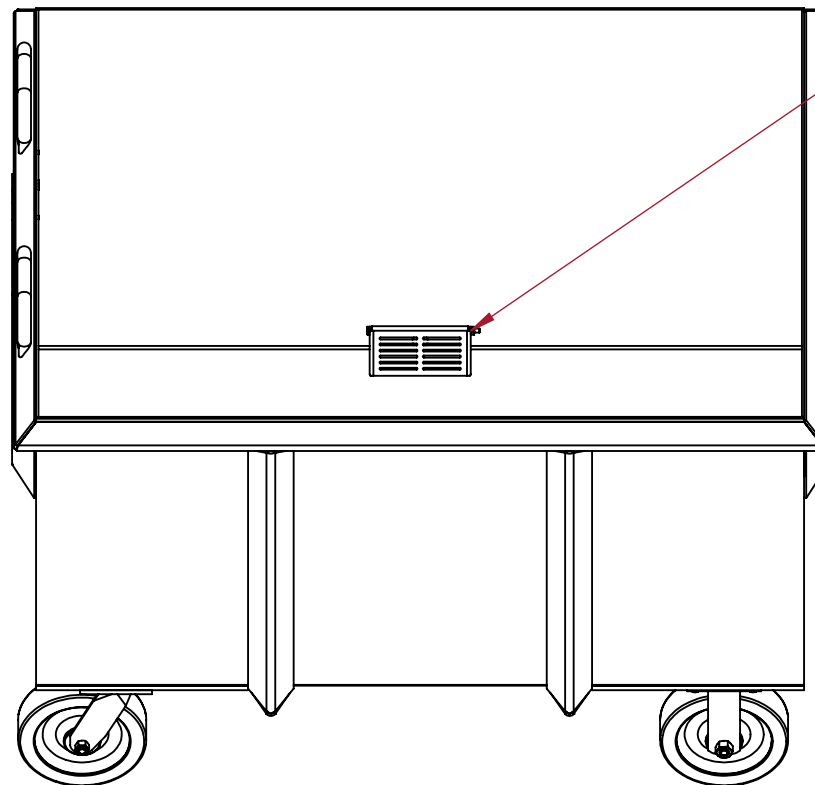

DRAIN FLAPPER

A

A

CECOR* 1000 Jamse Ave.
 Belleville, WI 53508
 Phone: (608) 845-6771
 Email: cecor@cecor.net

**PROPRIETARY AND
 CONFIDENTIAL:**
 THE INFORMATION
 CONTAINED IN THIS
 DRAWING IS THE SOLE
 PROPERTY OF CECOR.
 ANY REPRODUCTION IN
 PART OR AS A WHOLE
 WITHOUT THE WRITTEN
 PERMISSION OF CECOR
 IS PROHIBITED.

UNITS: INCHES
 TOLERANCES:
 FRAC: ± 1/32"
 DEC: ±0.03

TITLE:
**256 SALES DWG
 OPTIONAL DRAIN
 FLAPPER**

DRAWN: BY BPU DATE 01/25/24	DWG. NO. ACT0.0075	REV 3
---	------------------------------	-----------------

CUSTOMER SIGN OFF: _____ DATE: _____

2

1