

2

1

B

B

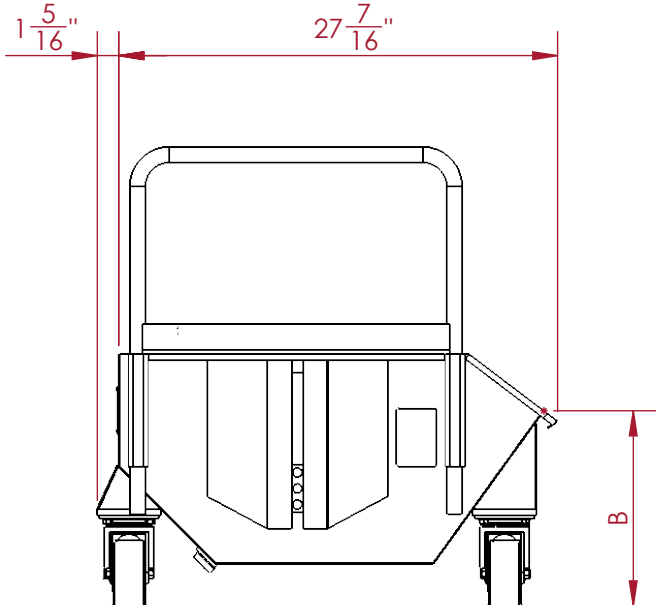
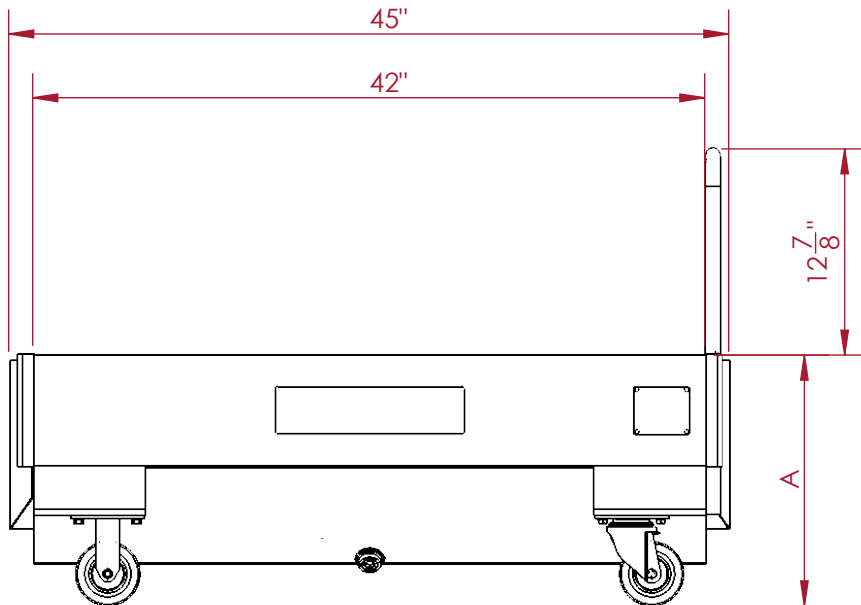

A

A

CASTER SIZE	CART HEIGHT "A"	LIP HEIGHT "B"
3"	14 ⁵ / ₁₆ "	10 ¹³ / ₁₆ "
4"	15 ¹¹ / ₁₆ "	12 ³ / ₁₆ "
5"	16 ² / ₁₆ "	13 ¹ / ₁₆ "

CECOR* 1000 Jamse Ave.
 Belleville, WI 53508
 Phone: (608) 845-6771
 Email: cecor@cecor.net

TITLE: **L44 SALES DWG**

PROPRIETARY AND CONFIDENTIAL:
 THE INFORMATION CONTAINED IN THIS DRAWING IS THE SOLE PROPERTY OF CECOR. ANY REPRODUCTION IN PART OR AS A WHOLE WITHOUT THE WRITTEN PERMISSION OF CECOR IS PROHIBITED.

UNITS: INCHES
 TOLERANCES:
 FRAC: ± 1/32"
 DEC: ±0.03

DRAWN: BY BPU DATE 01/25/24	DWG. NO. ACT0.0069	REV 3
---	------------------------------	-----------------

CUSTOMER SIGN OFF: _____ DATE: _____

2

1

2

1

B

B

48 ¹/₂"

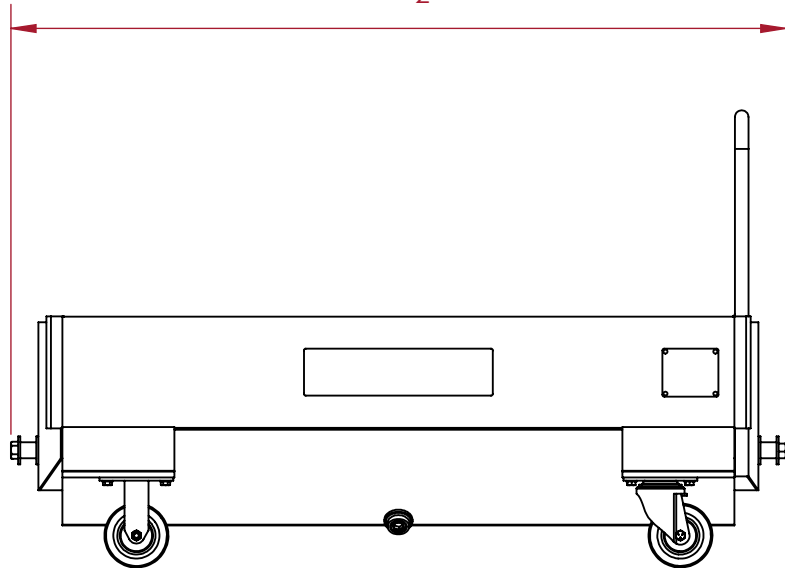

TRUNNION HARDWARE

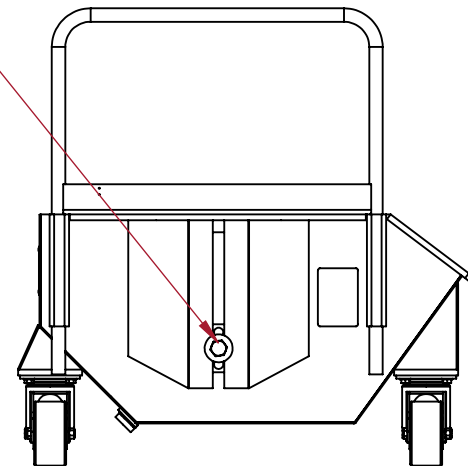

WORKS WITH DF-1044 DUMPING FRAME

A

A

CECOR* 1000 Jamse Ave.
 Belleville, WI 53508
 Phone: (608) 845-6771
 Email: cecor@cecor.net

PROPRIETARY AND CONFIDENTIAL:
 THE INFORMATION CONTAINED IN THIS DRAWING IS THE SOLE PROPERTY OF CECOR. ANY REPRODUCTION IN PART OR AS A WHOLE WITHOUT THE WRITTEN PERMISSION OF CECOR IS PROHIBITED.

UNITS: INCHES
 TOLERANCES:
 FRAC: ± 1/32"
 DEC: ±0.03

TITLE:
L44 SALES DWG
TRUNNION HARDWARE

DRAWN:
 BY
 BPU
 DATE
 01/25/24

DWG. NO.
ACT0.0069

REV
3

CUSTOMER SIGN OFF: _____ DATE: _____

2

1

2

1

B

B

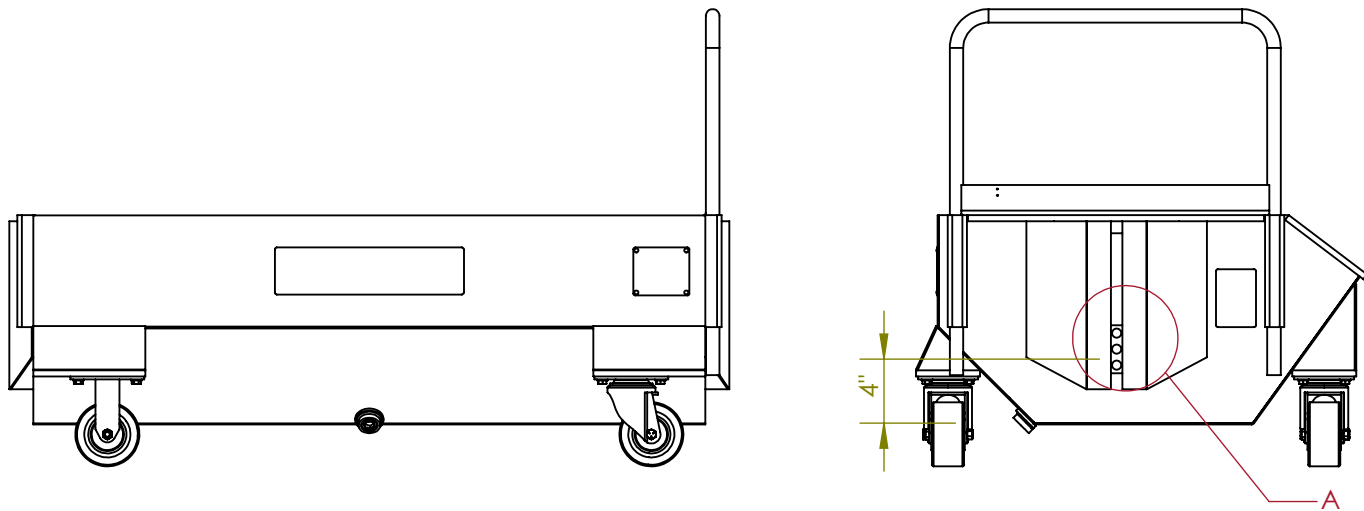

TEE-RAIL CLEAT PACKAGE IS
DEPENDENT ON THE CASTER SIZE

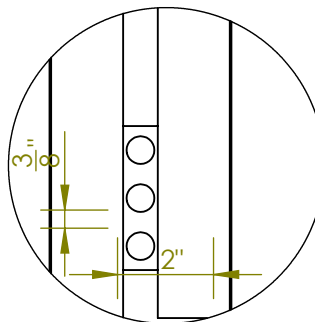

DETAIL A
SCALE 1 : 4

**PROPRIETARY AND
CONFIDENTIAL:**
THE INFORMATION
CONTAINED IN THIS
DRAWING IS THE SOLE
PROPERTY OF CECOR.
ANY REPRODUCTION IN
PART OR AS A WHOLE
WITHOUT THE WRITTEN
PERMISSION OF CECOR
IS PROHIBITED.

UNITS: INCHES
TOLERANCES:
FRAC: ± 1/32"
DEC: ±0.03

CECOR* 1000 Jamse Ave.
Belleville, WI 53508
Phone: (608) 845-6771
Email: cecor@cecor.net

TITLE: L44 SALES DWG

CUSTOMER SIGN OFF: _____ DATE: _____

DRAWN:
BY
BPU
DATE
01/25/24

DWG. NO.
ACT0.0069

REV
3

2

1

A

A

2

1

B

B

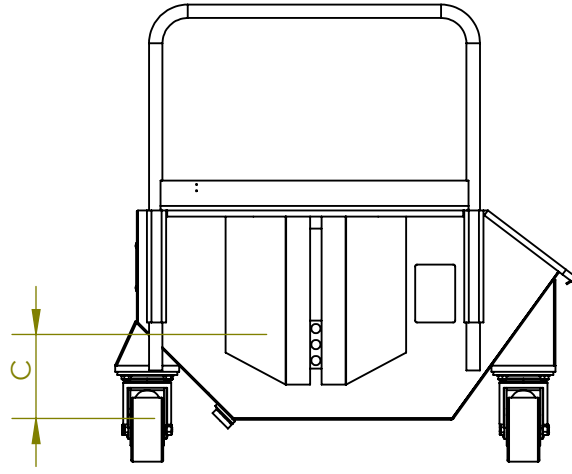
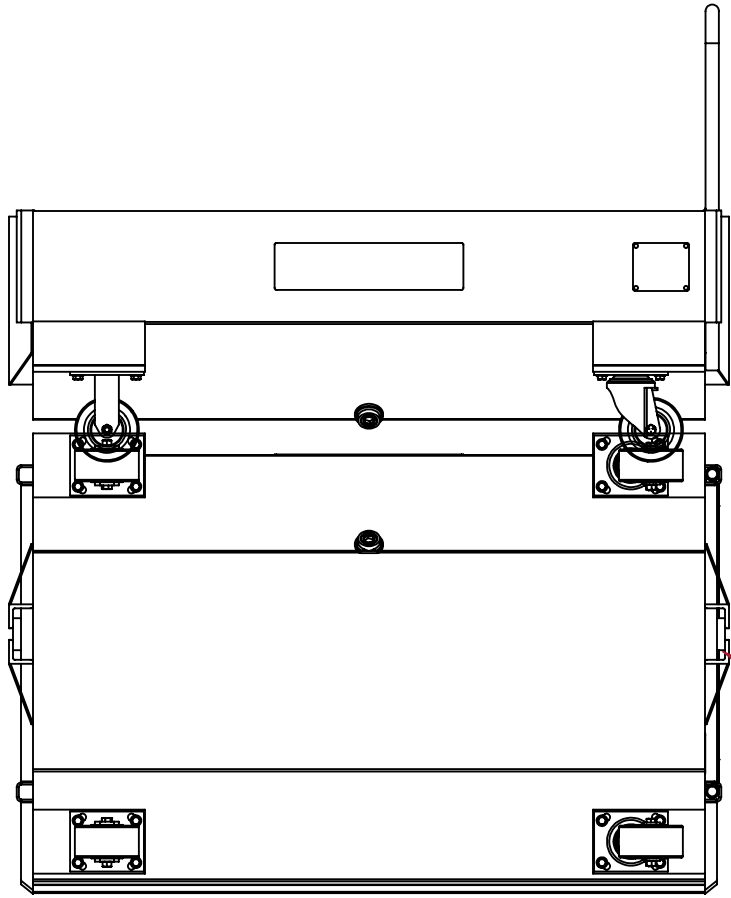

CASTER SIZE	HITCH HEIGHT "C"
3"	3"
4"	4 ³ / ₈ "
5"	5 ¹ / ₄ "
6"	6 ¹ / ₄ "
8"	8 ¹ / ₄ "

ROBOTIC TOWING HITCH

A

A

CECOR* 1000 Jamse Ave.
 Belleville, WI 53508
 Phone: (608) 845-6771
 Email: cecor@cecor.net

TITLE: L44 SALES DWG

PROPRIETARY AND CONFIDENTIAL:
 THE INFORMATION CONTAINED IN THIS DRAWING IS THE SOLE PROPERTY OF CECOR. ANY REPRODUCTION IN PART OR AS A WHOLE WITHOUT THE WRITTEN PERMISSION OF CECOR IS PROHIBITED.

UNITS: INCHES
 TOLERANCES:
 FRAC: ± 1/32"
 DEC: ±0.03

DRAWN: BY BPU
 DATE 01/25/24

DWG. NO. ACT0.0069

REV 3

CUSTOMER SIGN OFF: _____ DATE: _____

2

1

2

1

B

B

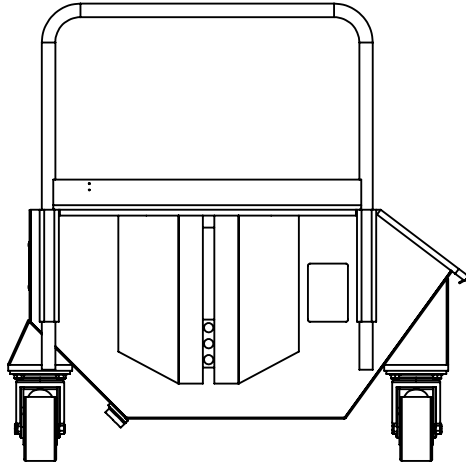
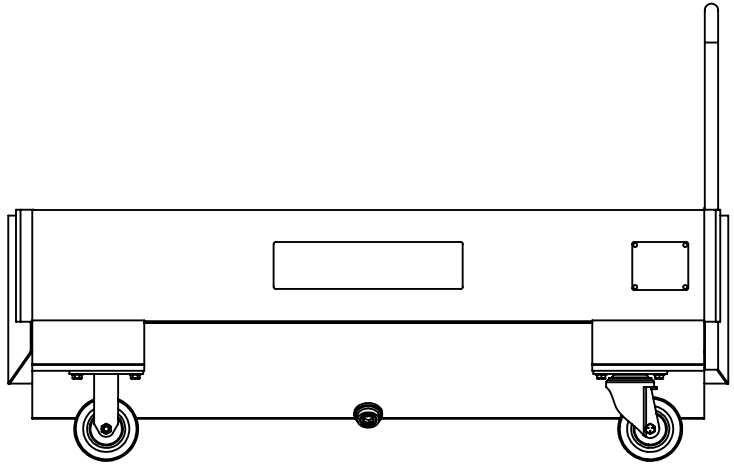

TEE-RAIL CLEAT

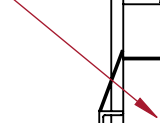

ROBOTIC TOWING HITCH

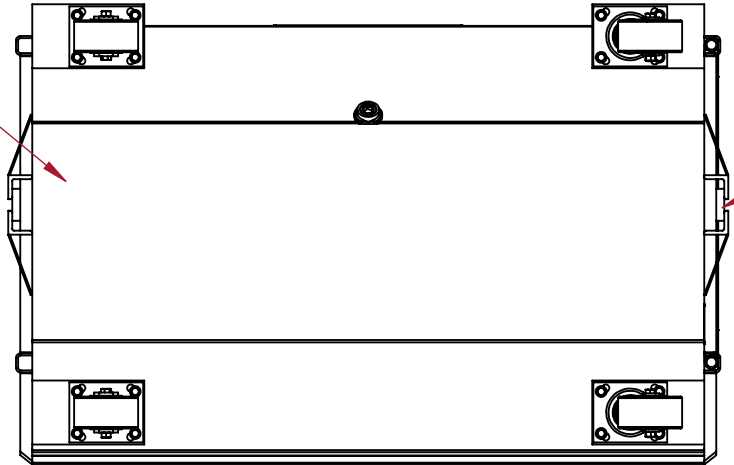

A

A

CECOR* 1000 Jamse Ave.
 Belleville, WI 53508
 Phone: (608) 845-6771
 Email: cecor@cecor.net

TITLE: L44 SALES DWG

PROPRIETARY AND CONFIDENTIAL:
 THE INFORMATION CONTAINED IN THIS DRAWING IS THE SOLE PROPERTY OF CECOR. ANY REPRODUCTION IN PART OR AS A WHOLE WITHOUT THE WRITTEN PERMISSION OF CECOR IS PROHIBITED.

UNITS: INCHES
 TOLERANCES:
 FRAC: ± 1/32"
 DEC: ±0.03

DRAWN:
 BY BPU
 DATE 01/25/24

DWG. NO. ACT0.0069

REV 3

CUSTOMER SIGN OFF: _____ DATE: _____

2

1

2

1

B

B

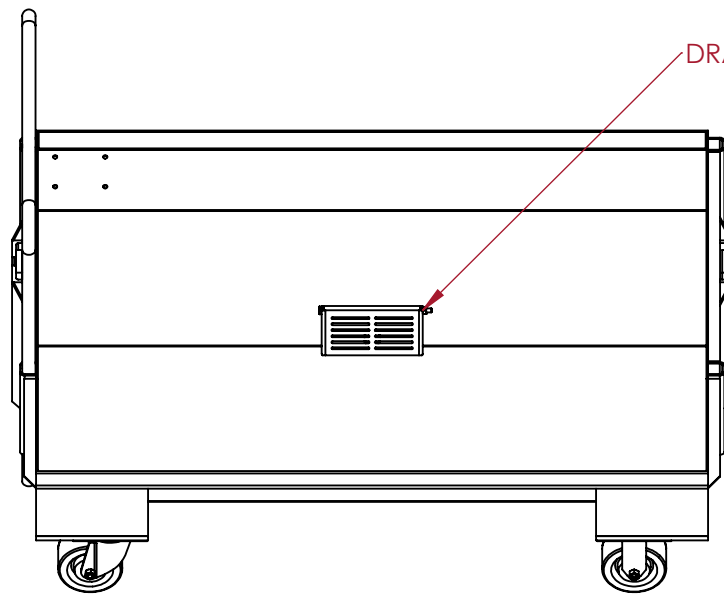

DRAIN FLAPPER

A

A

CECOR* 1000 Jamse Ave.
 Belleville, WI 53508
 Phone: (608) 845-6771
 Email: cecor@cecor.net

PROPRIETARY AND CONFIDENTIAL:
 THE INFORMATION CONTAINED IN THIS DRAWING IS THE SOLE PROPERTY OF CECOR. ANY REPRODUCTION IN PART OR AS A WHOLE WITHOUT THE WRITTEN PERMISSION OF CECOR IS PROHIBITED.

TITLE:
**L44 SALES DWG
 DRAIN FLAPPER**

CUSTOMER SIGN OFF: _____ DATE: _____

UNITS: INCHES
 TOLERANCES:
 FRAC: ± 1/32"
 DEC: ±0.03

DRAWN: BY BPU DATE 01/25/24	DWG. NO. ACT0.0069	REV 3
---	------------------------------	-----------------

2

1