

B

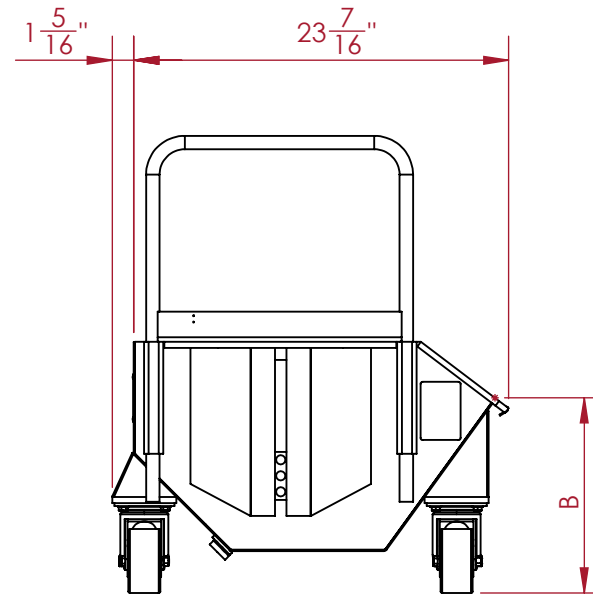
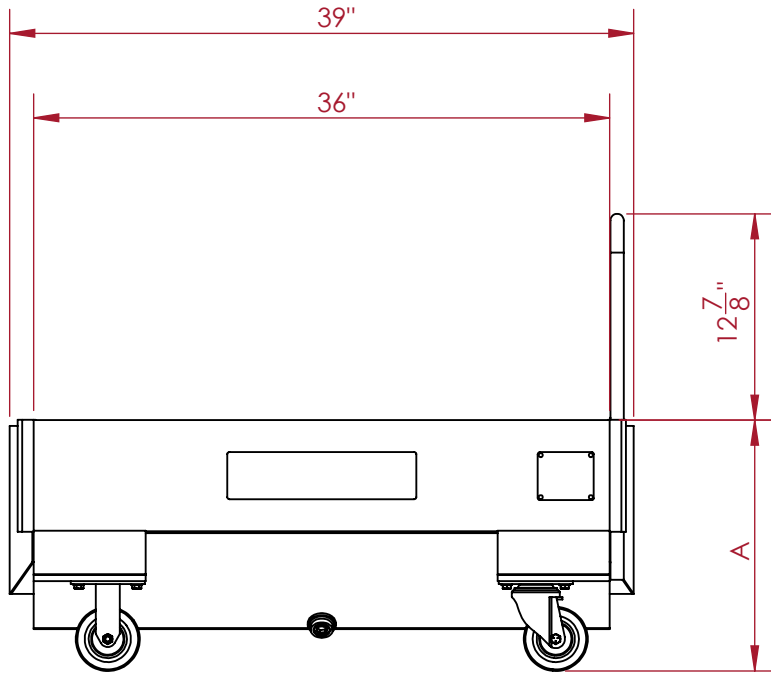

B

CASTER SIZE	CART HEIGHT "A"	LIP HEIGHT "B"
3"	14 5/16"	10 13/16"
4"	15 11/16"	12 3/16"
5"	16 2/16"	13 1/16"

A

CUSTOMER SIGN OFF: \_\_\_\_\_ DATE: \_\_\_\_\_

**PROPRIETARY AND CONFIDENTIAL:**

THE INFORMATION CONTAINED IN THIS DRAWING IS THE SOLE PROPERTY OF CECOR. ANY REPRODUCTION IN PART OR AS A WHOLE WITHOUT THE WRITTEN PERMISSION OF CECOR IS PROHIBITED.

UNITS: INCHES  
TOLERANCES:  
FRAC: ± 1/32"  
DEC: ±0.03

**CECOR**\*

1000 Jamse Ave.  
Belleville, WI 53508  
Phone: (608) 845-6771  
Email: cecor@cecor.net

TITLE:

L43 SALES DWG

DRAWN:  
BY  
BPU  
DATE  
01/25/24

DWG. NO.  
ACT0.0068

REV  
3

2

1

2

1

B

B

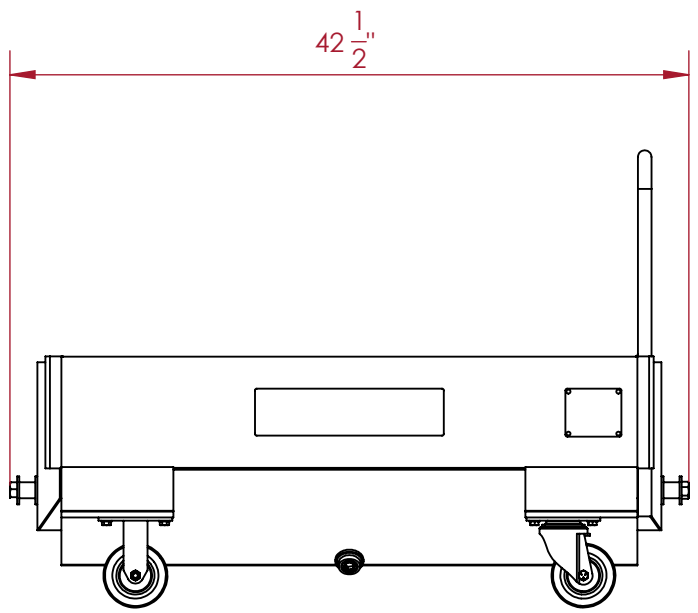

TRUNNION HARDWARE

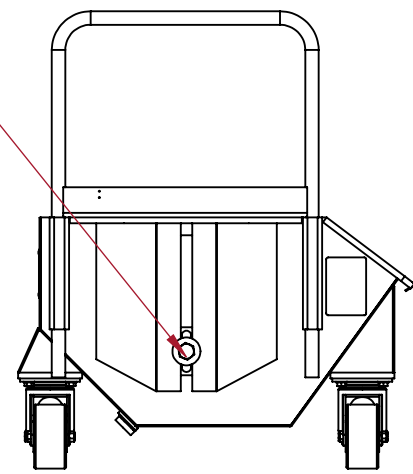

WORKS WITH DF-1043 DUMPING FRAME

A

A

**CECOR**\* 1000 Jamse Ave.  
 Belleville, WI 53508  
 Phone: (608) 845-6771  
 Email: cecor@cecor.net

**PROPRIETARY AND CONFIDENTIAL:**  
 THE INFORMATION CONTAINED IN THIS DRAWING IS THE SOLE PROPERTY OF CECOR. ANY REPRODUCTION IN PART OR AS A WHOLE WITHOUT THE WRITTEN PERMISSION OF CECOR IS PROHIBITED.

TITLE:  
**L43 SALES DWG  
 TRUNNION HARDWARE**

CUSTOMER SIGN OFF: \_\_\_\_\_ DATE: \_\_\_\_\_

UNITS: INCHES  
 TOLERANCES:  
 FRAC: ± 1/32"  
 DEC: ±0.03

DRAWN: BY BPU DATE 01/25/24	DWG. NO. <b>ACT0.0068</b>	REV <b>3</b>
---	------------------------------	-----------------

2

1

2

1

B

B

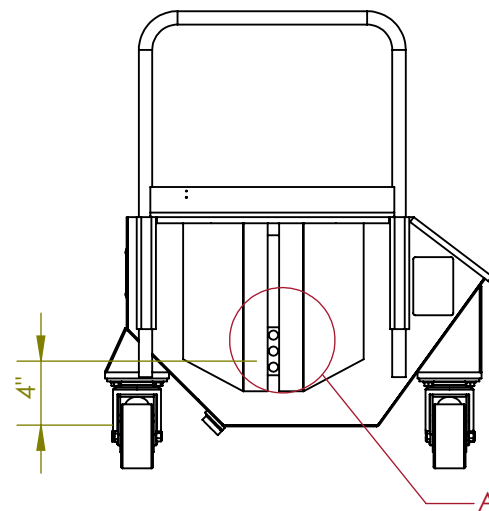
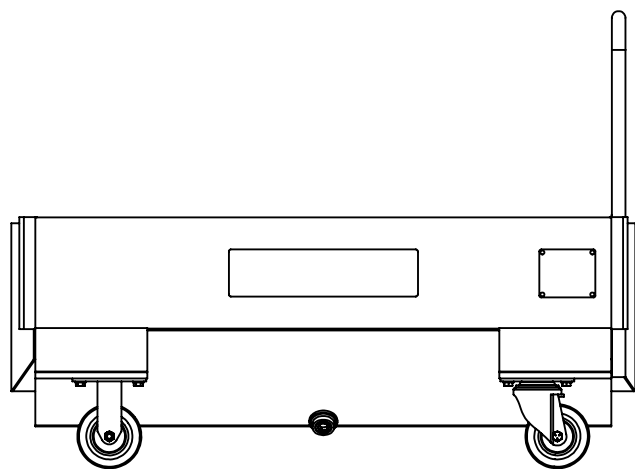

A

A

TEE-RAIL CLEAT PACKAGE IS  
DEPENDENT ON THE CASTER SIZE

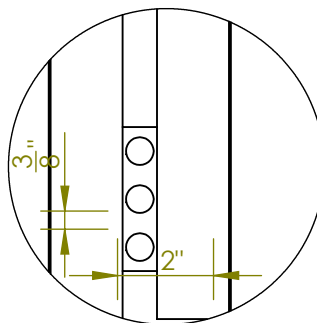

DETAIL A  
SCALE 1 : 4

PROPRIETARY AND  
CONFIDENTIAL:  
THE INFORMATION  
CONTAINED IN THIS  
DRAWING IS THE SOLE  
PROPERTY OF CECOR.  
ANY REPRODUCTION IN  
PART OR AS A WHOLE  
WITHOUT THE WRITTEN  
PERMISSION OF CECOR  
IS PROHIBITED.

UNITS: INCHES  
TOLERANCES:  
FRAC: ± 1/32"  
DEC: ±0.03

**CECOR**\*

1000 Jamse Ave.  
Belleville, WI 53508  
Phone: (608) 845-6771  
Email: cecor@cecor.net

TITLE: L43 SALES DWG

CUSTOMER SIGN OFF: \_\_\_\_\_ DATE: \_\_\_\_\_

DRAWN:  
BY  
BPU  
DATE  
01/25/24

DWG. NO.  
ACT0.0068

REV  
3

2

1

2

1

B

B

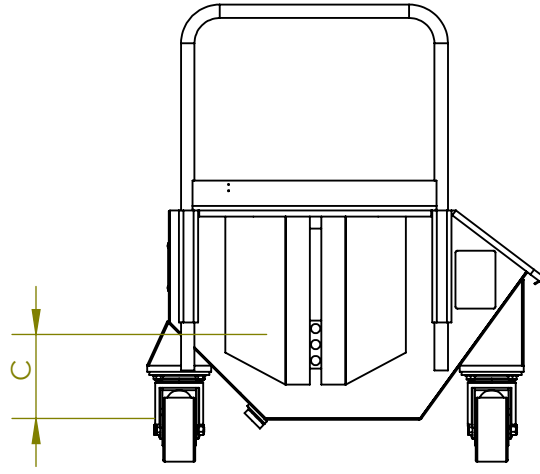
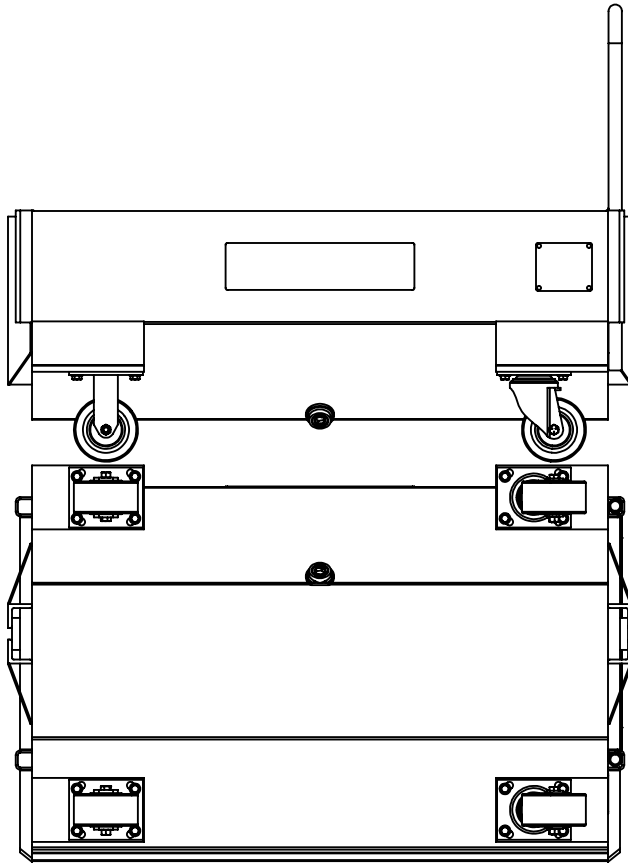

CASTER SIZE	HITCH HEIGHT "C"
3"	3"
4"	4 <sup>3</sup> / <sub>8</sub> "
5"	5 <sup>1</sup> / <sub>4</sub> "
6"	6 <sup>1</sup> / <sub>4</sub> "
8"	8 <sup>1</sup> / <sub>4</sub> "

ROBOTIC TOWING HITCH

A

A

**CECOR**\* 1000 Jamse Ave.  
 Belleville, WI 53508  
 Phone: (608) 845-6771  
 Email: cecor@cecor.net

TITLE: L43 SALES DWG

PROPRIETARY AND CONFIDENTIAL:  
 THE INFORMATION CONTAINED IN THIS DRAWING IS THE SOLE PROPERTY OF CECOR. ANY REPRODUCTION IN PART OR AS A WHOLE WITHOUT THE WRITTEN PERMISSION OF CECOR IS PROHIBITED.

UNITS: INCHES  
 TOLERANCES:  
 FRAC: ± 1/32"  
 DEC: ±0.03

DRAWN:  
 BY BPU  
 DATE  
 01/25/24

DWG. NO.  
 ACT0.0068

REV  
 3

CUSTOMER SIGN OFF: \_\_\_\_\_ DATE: \_\_\_\_\_

2

1

2

1

B

B

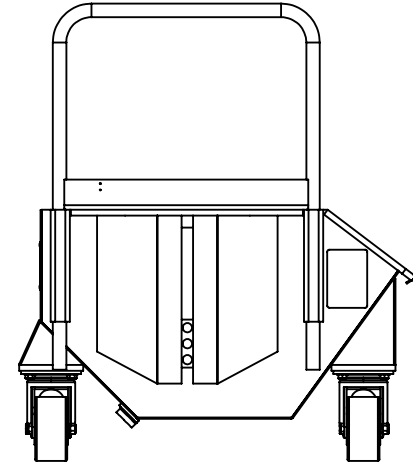
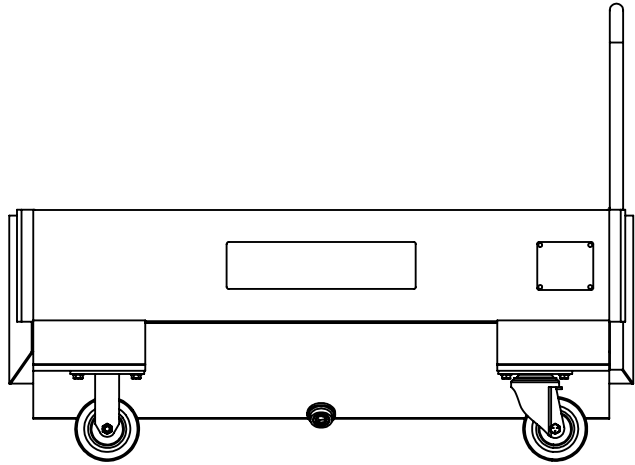

TEE-RAIL CLEAT

ROBOTIC TOWING HITCH

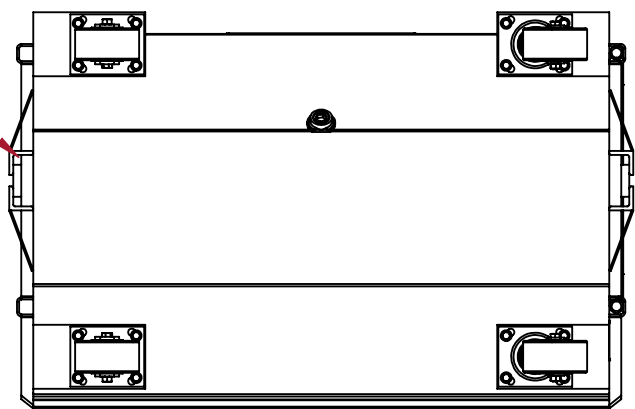

A

A

**CECOR**\* 1000 Jamse Ave.  
 Belleville, WI 53508  
 Phone: (608) 845-6771  
 Email: cecor@cecor.net

TITLE: L43 SALES DWG

PROPRIETARY AND CONFIDENTIAL:  
 THE INFORMATION CONTAINED IN THIS DRAWING IS THE SOLE PROPERTY OF CECOR. ANY REPRODUCTION IN PART OR AS A WHOLE WITHOUT THE WRITTEN PERMISSION OF CECOR IS PROHIBITED.

UNITS: INCHES  
 TOLERANCES:  
 FRAC: ± 1/32"  
 DEC: ±0.03

DRAWN: BY  
 BPU  
 DATE  
 01/25/24

DWG. NO.  
 ACT0.0068

REV  
 3

CUSTOMER SIGN OFF: \_\_\_\_\_ DATE: \_\_\_\_\_

2

1

2

1

B

B

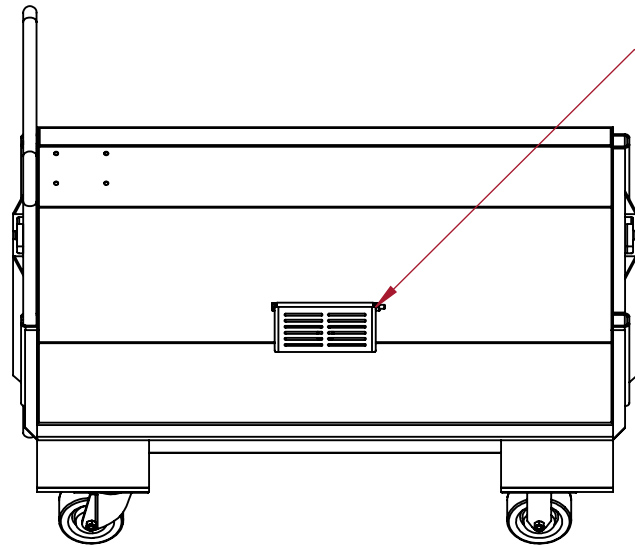

DRAIN FLAPPER

A

A

**CECOR**\* 1000 Jamse Ave.  
 Belleville, WI 53508  
 Phone: (608) 845-6771  
 Email: cecor@cecor.net

**PROPRIETARY AND CONFIDENTIAL:**  
 THE INFORMATION CONTAINED IN THIS DRAWING IS THE SOLE PROPERTY OF CECOR. ANY REPRODUCTION IN PART OR AS A WHOLE WITHOUT THE WRITTEN PERMISSION OF CECOR IS PROHIBITED.

TITLE: **L43 SALES DWG  
 DRAIN FLAPPER**

CUSTOMER SIGN OFF: \_\_\_\_\_ DATE: \_\_\_\_\_

UNITS: INCHES  
 TOLERANCES:  
 FRAC: ± 1/32"  
 DEC: ±0.03

DRAWN: BY BPU DATE 01/25/24	DWG. NO. <b>ACT0.0068</b>	REV <b>3</b>
---	------------------------------	-----------------

2

1