

2

1

B

B

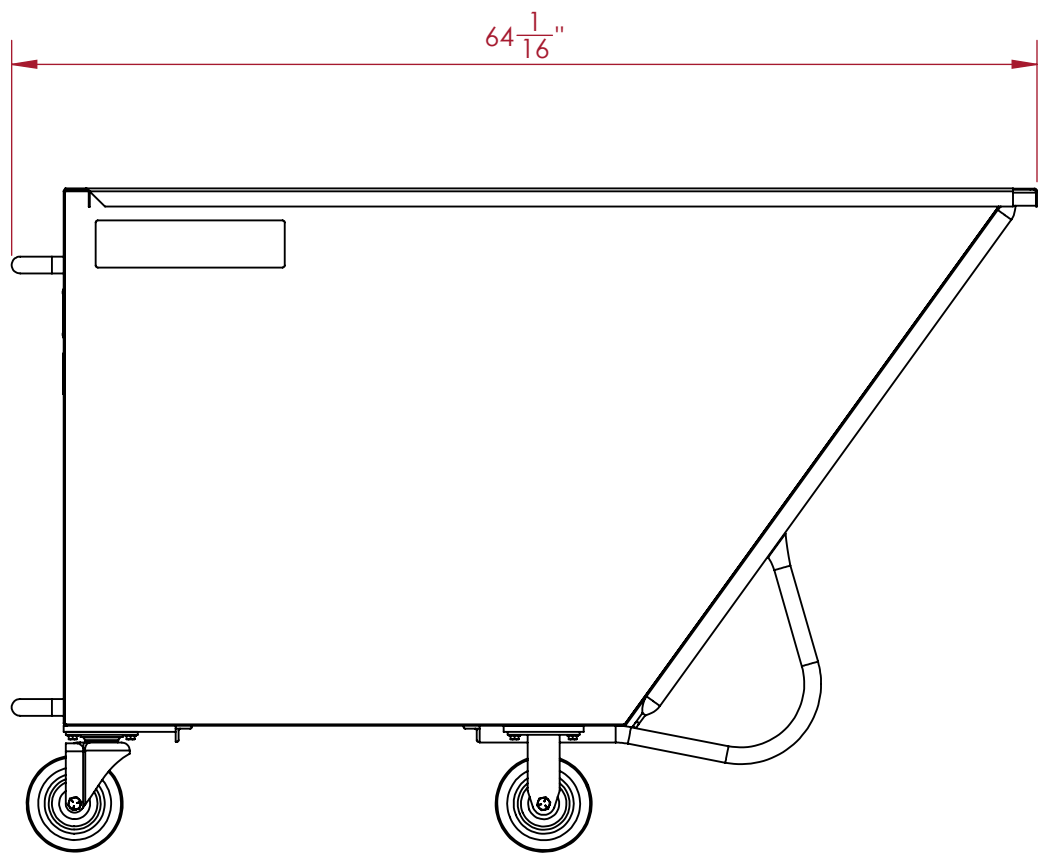
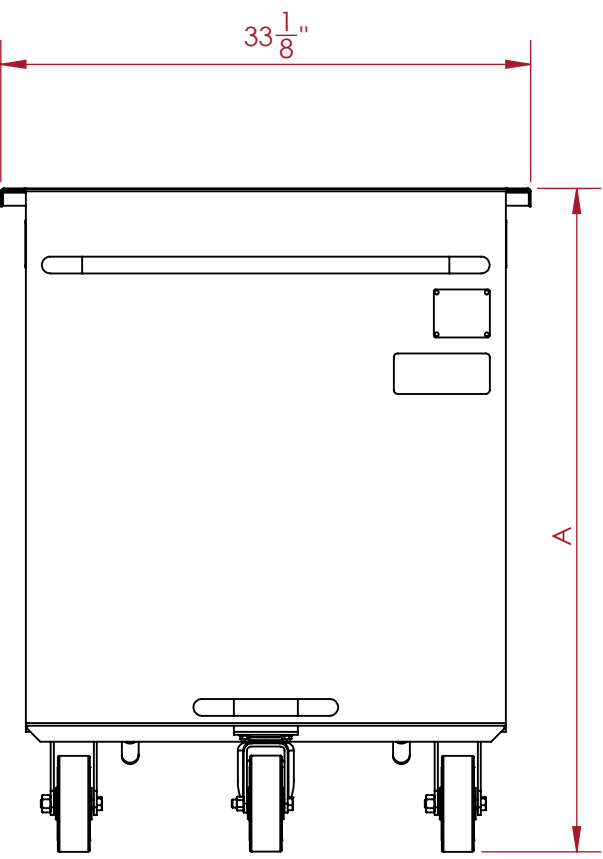

A

A

CASTER SIZE	CART HEIGHT "A"
5"	40½"
6"	41½"

CALL FOR OTHER CASTER SIZES.

CECOR* 1000 Jamse Ave.
 Belleville, WI 53508
 Phone: (608) 845-6771
 Email: cecor@cecor.net

TITLE: **327 SALES DWG**

PROPRIETARY AND CONFIDENTIAL:
 THE INFORMATION CONTAINED IN THIS DRAWING IS THE SOLE PROPERTY OF CECOR. ANY REPRODUCTION IN PART OR AS A WHOLE WITHOUT THE WRITTEN PERMISSION OF CECOR IS PROHIBITED.

UNITS: INCHES
 TOLERANCES:
 FRAC: ± 1/32"
 DEC: ±0.03

DRAWN: BY BPU DATE 11-09-23	DWG. NO. ACT0.0063	REV 5
---	------------------------------	-----------------

CUSTOMER SIGN OFF: _____ DATE: _____

2

1